



MODEL UMC UNIVERSAL MANIFOLD CHECK ASSEMBLY

(With or Without Control Valve)

1¼", 1½", 2", 2½", 76.1mm, 3", 4", 6", 165.1mm, 8"

GENERAL DESCRIPTION

The Globe Series "UMC" Universal Manifold Check is a first of its kind, UL Listed and FM Approved, complete floor control station or shotgun riser assembly. It is pressure rated for 300 psi (20,6 bar). It provides the most compact "footprint" while delivering all of the necessary components for your floor control station as required by the NFPA Standards. With its multiple available configurations, it allows the contractor to order the suitable configuration for the site specific needs. The "UMC" Universal Manifold Check is more than just a traditional stand-alone manifold. It serves as a complete floor control station as well as a complete shotgun riser assembly inclusive of Control Valve with Internal Supervisory Switch; Check Valve; Flow Switch; Test and Drain Assembly; Adjustable Pressure Relief Valve Assembly pre-piped to drain; supply gauge (4", 6" and 8") and system gauge (1 1/4" through 8"). The "UMC" Universal Manifold Check replaces the need to order individual "Riser Manifolds" plus control valves, check valves, and relief valve kits as all of these components are integrated into the one compact design, saving space as well as the labor to connect these separate components. For sizes 3" and smaller, an 18" long stainless steel braided flexible hose is included with the UMC for connecting the Test and Drain valve to a drain stack. The design takes into account both "left-hand" and "right-hand" orientations. (8" version available preassembled in right-hand orientation only)

FLOOR CONTROL ASSEMBLY

The UMC may be utilized to meet the NFPA 13 requirements for Floor Control Valve Assemblies where there are multistory buildings exceeding two stories in height requiring zoning by floor or whenever separate control and floor zoning is specified. The UMC has been engineered with space savings in mind for those commonly installed applications in stairwell landings and small alcoves. All UMC assemblies include the NFPA 13 required Listed Pressure Relief Valve which is pre-piped to drain. The relief valve is preset for 175 psi and is adjustable to 310 psi for high pressure system conditions. In addition to the relief valve, the UMC is equipped with a Test and Drain Valve. The Test and Drain Valve contains a test orifice of K2.8, K4.2 and K5.6 for 1", 1 1/4" and 2" respectively so that it may be utilized for flow testing any system with sprinklers having K-Factors of that size or larger.

Note: NFPA 13 requires that a test connection providing a flow rate equal to or less than one sprinkler of a type having the smallest orifice on the system is to be provided.

A pressure gauge is provided above the check valve clapper for sizes 1¼" through 3" to meet the gauge requirement per NFPA 13 for Floor Control Assemblies. Typically the supply side gauge is not required for multistory buildings with floor control stations as a system gauge would be on the main feed/riser but all Model UMC Manifold Check Valves are equipped with a 1/4" (DN 8) port below the clapper to accommodate a second gauge if desired.

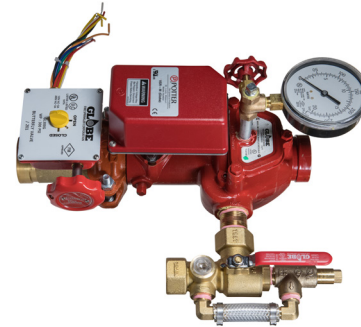

MODEL UMC UNIVERSAL MANIFOLD CHECK ASSEMBLY

SHOTGUN RISER ASSEMBLY

"Shotgun Riser Assemblies" are those assemblies which are typically installed in vertical orientations on individual system Risers. The Globe "Shotgun" Riser Manifold Assembly is available in 4 inch (DN 100), 6 inch (DN 150), and 8 inch (DN 200) sizes and is equipped with a control valve; check valve; flow switch; test and drain valve with NFPA required pressure relief valve; 2 gauges (system and supply). Sizes 4 inch (DN 100), 6 inch (DN 150), and 8 inch (DN 200) are equipped with a pressure gauge on both system side and supply side of the check valve clapper. The 8" UMC consists of a Universal Manifold, a Victaulic Series 717 Grooved Check Valve and an optional Victaulic Series 705 Grooved Butterfly Valve.

TECHNICAL DATA

Approvals

- cULus
- FM

Maximum System Working Pressure

- 300 psi (20.6 Bar)

End Connections

- See Table A

Materials of Construction

- See Figure 1

*Multiple Patents Pending

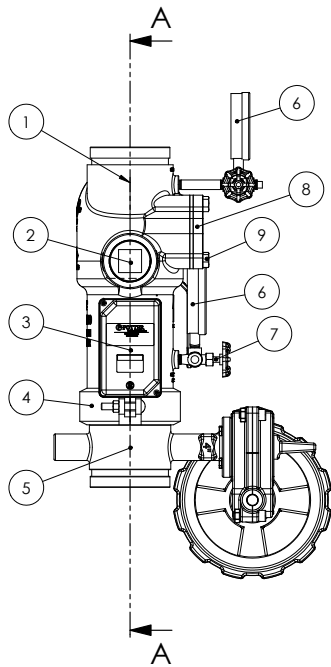

SIDE VIEW

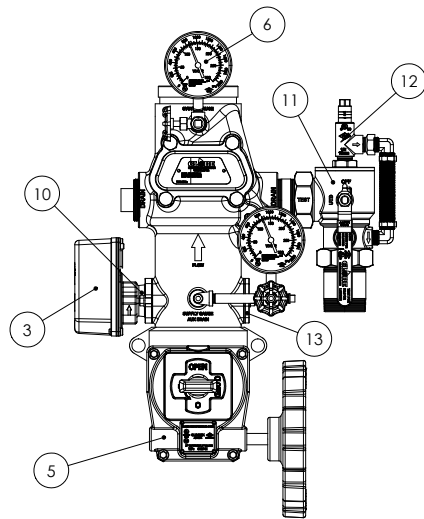

FRONT VIEW

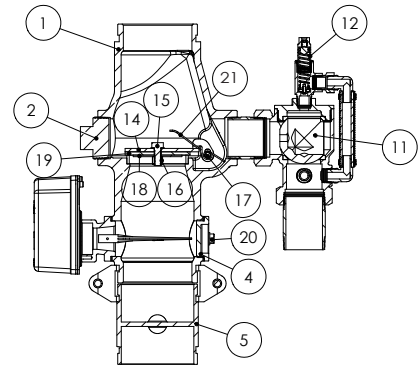

SECTION A-A

ITEM NO.	DESCRIPTION	MATERIAL
1	UMC VALVE BODY	DUCTILE IRON
2	RECESSED HEX PLUG	STAINLESS STEEL
3	FLOW SWITCH	SEE FLOW SWITCH TECHNICAL LITERATURE
4	RIGID COUPLING	SEE COUPLING TECHNICAL LITERATURE
5	BUTTERFLY CONTROL VALVE WITH INTERNAL SUPERVISORY SWITCH	SEE GLOBE BUTTERFLY CONTROL VALVE TECHNICAL LITERATURE
6	PRESSURE GAUGE	PLASTIC
7	THREEWAY VALVE	BRONZE
8	UMC COVER PLATE	DUCTILE IRON
9	BOLT	STAINLESS STEEL
10	FLOW SWITCH ADAPTER	DUCTILE IRON
11	MODEL UTD TEST AND DRAIN	SEE GLOBE TECHNICAL DATASHEET GFV570
12	MODEL ARV ADJUSTABLE RELIEF VALVE	SEE VICTAULIC SUBMITTAL 30.74
13	FLOW SWITCH PLUG	DUCTILE IRON
14	UMC VALVE CLAPPER	STAINLESS STEEL
15	UMC VALVE CLAPPER RETAINING BOLT	STAINLESS STEEL
16	UMC VALVE CLAPPER RETAINING NUT	STAINLESS STEEL
17	UMC VALVE HINGE PIN	STAINLESS STEEL
18	CLAPPER FACING RETAINING RING	STAINLESS STEEL
19	CLAPPER FACING	EDPM
20	FLOW SWITCH PLUG BOLT	STAINLESS STEEL
21	CLAPPER SPRING	STAINLESS STEEL

NOTE:

- 4" (DN100) shown as reference
- See ordering procedure for replacement part kits and Table A through G for part numbers for all sizes and configurations
- Flow switch rotated 90 degrees on 1-1/4" through 2 1/2" sizes

**FIGURE 1: MODEL UMC MANIFOLD CHECK ASSEMBLY
MATERIALS OF CONSTRUCTION
(1 1/4" - 6")**

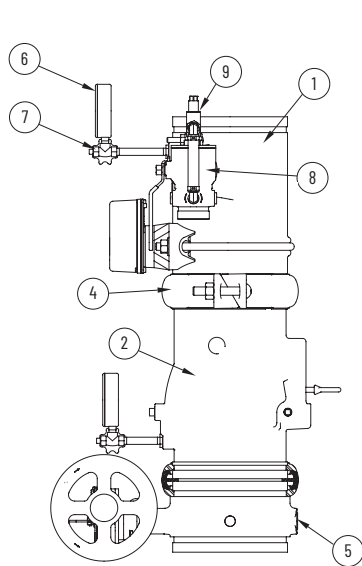

FRONT VIEW

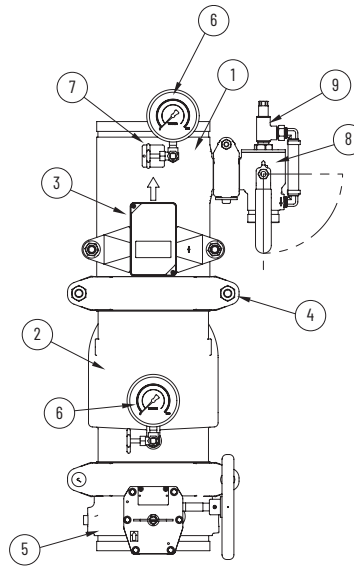

SIDE VIEW

ITEM NO.	DESCRIPTION	MATERIAL
1	UM VALVE BODY	DUCTILE IRON
2	SERIES 717 CHECK VALVE	DUCTILE IRON BODY SEE VICTAULIC SUBMITTAL 10.08
3	FLOW SWITCH	SEE FLOW SWITCH TECHNICAL LITERATURE
4	RIGID COUPLING	SEE COUPLING TECHNICAL LITERATURE
5	BUTTERFLY CONTROL VALVE WITH INTERNAL SUPERVISORY SWITCH	SEE VICTAULIC SUBMITTAL 10.81
6	PRESSURE GAUGE	PLASTIC
7	3-WAY SOG VALVE	BRONZE
8	MODEL UTD TEST AND DRAIN	SEE GLOBE TECHNICAL DATASHEET GFV570
9	MODEL ARV ADJUSTABLE RELIEF VALVE	SEE VICTAULIC SUBMITTAL 30.74

NOTE:

- See ordering procedure for replacement part kits and Table A through G for part numbers for all sizes and configurations

**FIGURE 2: MODEL UMC MANIFOLD CHECK ASSEMBLY
MATERIALS OF CONSTRUCTION
(8")**

MODEL UMC MANIFOLD CHECK VALVE ASSEMBLY LEFT HANDED VS RIGHT HANDED

Both the shotgun riser assembly and the floor control station assembly are available as left handed or right handed assembly. The determining factor of the left handed vs right handed is the position of the Model UTD Test and Drain. While looking at the faceplate with the Model UMC valve in the vertical orientation and flow upward (shotgun riser orientation), the posi-

tion of the Model UTD Test and Drain determines the "Hand" of the valve. If the Model UTD Test and Drain is connected to the port on the right side of the valve body, it is considered a right handed assembly. If the Model UTD Test and Drain is connected to the port on the left side of the Model UMC valve the assembly is considered left handed.

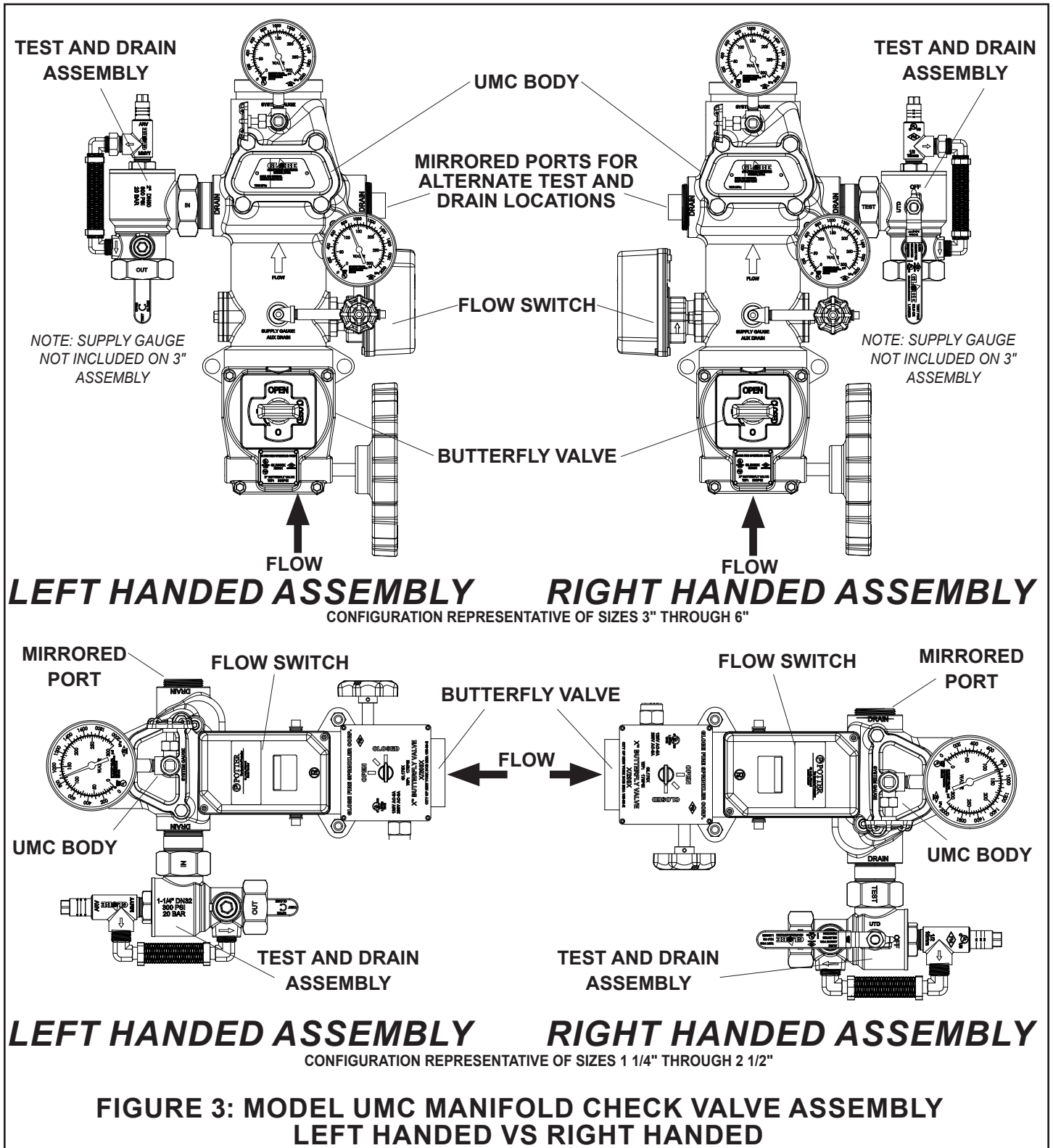

**FIGURE 3: MODEL UMC MANIFOLD CHECK VALVE ASSEMBLY
LEFT HANDED VS RIGHT HANDED**

TABLE A: 1¼" MODEL UMC ASSEMBLY CONFIGURATIONS

SIZE	ASSEMBLY R-RIGHT L-LEFT	CONTROL VALVE	UMC BODY END CONNECTIONS	MODEL UTD TEST AND DRAIN SIZE	PART NUMBER	APPROXIMATE SHIPPING WEIGHTS LBS. (kg)
1 1/4"	R	GL300T	MXF THREADED	1"	317800-R-B-H	24.0 (10.9)
1 1/4"	R	NONE	MXF THREADED	1"	317800-R-H	19.0 (8.6)
1 1/4"	L	GL300T	MXF THREADED	1"	317800-L-B-H	24.0 (10.9)
1 1/4"	L	NONE	MXF THREADED	1"	317800-L-H	19.0 (8.6)
1 1/4"	R	NONE	GXG	1"	317843-R-H	19.0 (8.6)
1 1/4"	R	GL300G	GXG	1"	317843-R-B-H	24.0 (10.9)
1 1/4"	R	SERIES 728	GXG	1"	317843-R-V-H	24.0 (10.9)
1 1/4"	L	NONE	GXG	1"	317843-L-H	19.0 (8.6)
1 1/4"	L	GL300G	GXG	1"	317843-L-B-H	24.0 (10.9)
1 1/4"	L	SERIES 728	GXG	1"	317843-L-V-H	24.0 (10.9)

TABLE B: 1½" MODEL UMC ASSEMBLY CONFIGURATIONS

SIZE	ASSEMBLY R-RIGHT L-LEFT	CONTROL VALVE	UMC BODY END CONNECTIONS	MODEL UTD TEST AND DRAIN SIZE	PART NUMBER	APPROXIMATE SHIPPING WEIGHTS LBS. (kg)
1 1/2"	R	GL300T	MXF THREADED	1"	317803-R-B-H	24.0 (10.9)
1 1/2"	R	NONE	MXF THREADED	1"	317803-R-H	18.3 (8.3)
1 1/2"	L	GL300T	MXF THREADED	1"	317803-L-B-H	24.0 (10.9)
1 1/2"	L	NONE	MXF THREADED	1"	317803-L-H	18.3 (8.3)
1 1/2"	R	NONE	GXG	1"	317844-R-H	18.3 (8.3)
1 1/2"	R	GL300G	GXG	1"	317844-R-B-H	24.0 (10.9)
1 1/2"	R	SERIES 728	GXG	1"	317844-R-V-H	24.0 (10.9)
1 1/2"	L	NONE	GXG	1"	317844-L-H	18.3 (8.3)
1 1/2"	L	GL300G	GXG	1"	317844-L-B-H	24.0 (10.9)
1 1/2"	L	SERIES 728	GXG	1"	317844-L-V-H	24.0 (10.9)

TABLE C: 2" MODEL UMC ASSEMBLY CONFIGURATIONS

SIZE	ASSEMBLY R-RIGHT L-LEFT	CONTROL VALVE	UMC BODY END CONNECTIONS	MODEL UTD TEST AND DRAIN SIZE	PART NUMBER	APPROXIMATE SHIPPING WEIGHTS LBS. (kg)
2"	R	GL300G	GXG	1"	317806-R-B-H	26.0 (11.8)
2"	R	SERIES 705	GXG	1"	317806-R-V-H	26.0 (11.8)
2"	R	NONE	GXG	1"	317806-R-H	19.2 (8.7)
2"	L	GL300G	GXG	1"	317806-L-B-H	26.0 (11.8)
2"	L	SERIES 705	GXG	1"	317806-L-V-H	26.0 (11.8)
2"	L	NONE	GXG	1"	317806-L-H	19.2 (8.7)

TABLE D: 2 1/2" (DN65)/76.1 MM MODEL UMC ASSEMBLY CONFIGURATIONS

SIZE	ASSEMBLY R-RIGHT L-LEFT	CONTROL VALVE	UMC BODY END CONNECTIONS	MODEL UTD TEST AND DRAIN SIZE	PART NUMBER	APPROXIMATE SHIPPING WEIGHTS LBS. (kg)
2 1/2"	R	GL300G	GXG	1 1/4"	317809-R-B-H	31.0 (14.1)
2 1/2"	R	SERIES 705	GXG	1 1/4"	317809-R-V-H	31.0 (14.1)
2 1/2"	R	NONE	GXG	1 1/4"	317809-R-H	23.5 (10.7)
2 1/2"	L	GL300G	GXG	1 1/4"	317809-L-B-H	31.0 (14.1)
2 1/2"	L	SERIES 705	GXG	1 1/4"	317809-L-V-H	31.0 (14.1)
2 1/2"	L	NONE	GXG	1 1/4"	317809-L-H	23.5 (10.7)
76.1 mm	R	GLR300G	GXG	1 1/4"	317809-D-R-B-H	31.0 (14.1)
76.1 mm	R	NONE	GXG	1 1/4"	317809-D-R-H	23.5 (10.7)
76.1 mm	L	GLR300G	GXG	1 1/4"	317809-D-L-B-H	31.0 (14.1)
76.1 mm	L	NONE	GXG	1 1/4"	317809-D-L-H	23.5 (10.7)

TABLE E: 3" MODEL UMC ASSEMBLY CONFIGURATIONS

SIZE	ASSEMBLY R-RIGHT L-LEFT	CONTROL VALVE	UMC BODY END CONNECTIONS	MODEL UTD TEST AND DRAIN SIZE	PART NUMBER	APPROXIMATE SHIPPING WEIGHTS LBS. (kg)
3"	R	GLR300G	GXG	1 1/4"	317812-R-B-H	59.0 (26.8)
3"	R	SERIES 705	GXG	1 1/4"	317812-R-V-H	59.0 (26.8)
3"	R	NONE	GXG	1 1/4"	317812-R-H	35.4 (16.1)
3"	L	GLR300G	GXG	1 1/4"	317812-L-B-H	59.0 (26.8)
3"	L	SERIES 705	GXG	1 1/4"	317812-L-V-H	59.0 (26.8)
3"	L	NONE	GXG	1 1/4"	317812-L-H	35.4 (16.1)

TABLE F: 4" MODEL UMC ASSEMBLY CONFIGURATIONS

SIZE	ASSEMBLY R-RIGHT L-LEFT	CONTROL VALVE	UMC BODY END CONNECTIONS	MODEL UTD TEST AND DRAIN SIZE	PART NUMBER	APPROXIMATE SHIPPING WEIGHTS LBS. (kg)
4"	R	GLR300G	GXG	2"	317817-R-B	87.5 (39.7)
4"	R	SERIES 705	GXG	2"	317817-R-V	87.5 (39.7)
4"	R	NONE	GXG	2"	317817-R	58.9 (26.7)
4"	L	GLR300G	GXG	2"	317817-L-B	87.5 (39.7)
4"	L	SERIES 705	GXG	2"	317817-L-V	87.5 (39.7)
4"	L	NONE	GXG	2"	317817-L	58.9 (26.7)

TABLE G: 6" (DN150)/165.1MM MODEL UMC ASSEMBLY CONFIGURATIONS

SIZE	ASSEMBLY R-RIGHT L-LEFT	CONTROL VALVE	UMC BODY END CONNECTIONS	MODEL UTD TEST AND DRAIN SIZE	PART NUMBER	APPROXIMATE SHIPPING WEIGHTS LBS. (kg)
6"	R	GLR300G	GXG	2"	317818-R-B	124.5 (56.5)
6"	R	SERIES 705	GXG	2"	317818-R-V	124.5 (56.5)
6"	R	NONE	GXG	2"	317818-R	80.0 (36.3)
6"	L	GLR300G	GXG	2"	317818-L-B	124.5 (56.5)
6"	L	SERIES 705	GXG	2"	317818-L-V	124.5 (56.5)
6"	L	NONE	GXG	2"	317818-L	80.0 (36.3)
165.1 mm	R	GLR300G	GXG	2"	317818-D-R-B	124.5 (56.5)
165.1 mm	R	NONE	GXG	2"	317818-D-R	80.0 (36.3)
165.1 mm	L	GLR300G	GXG	2"	317818-D-L-B	124.5 (56.5)
165.1 mm	L	NONE	GXG	2"	317818-D-L	80.0 (36.3)

TABLE H: 8" MODEL UMC ASSEMBLY CONFIGURATIONS

SIZE	ASSEMBLY R-RIGHT	CONTROL VALVE	UMC BODY END CONNECTIONS	MODEL UTD TEST AND DRAIN SIZE	PART NUMBER	APPROXIMATE WEIGHTS LBS. (kg)
8"	R	Series 705	GXG	2"	317798-01	177 (80.3)
8"	R	NONE	GXG	2"	317798-02	123 (55.8)

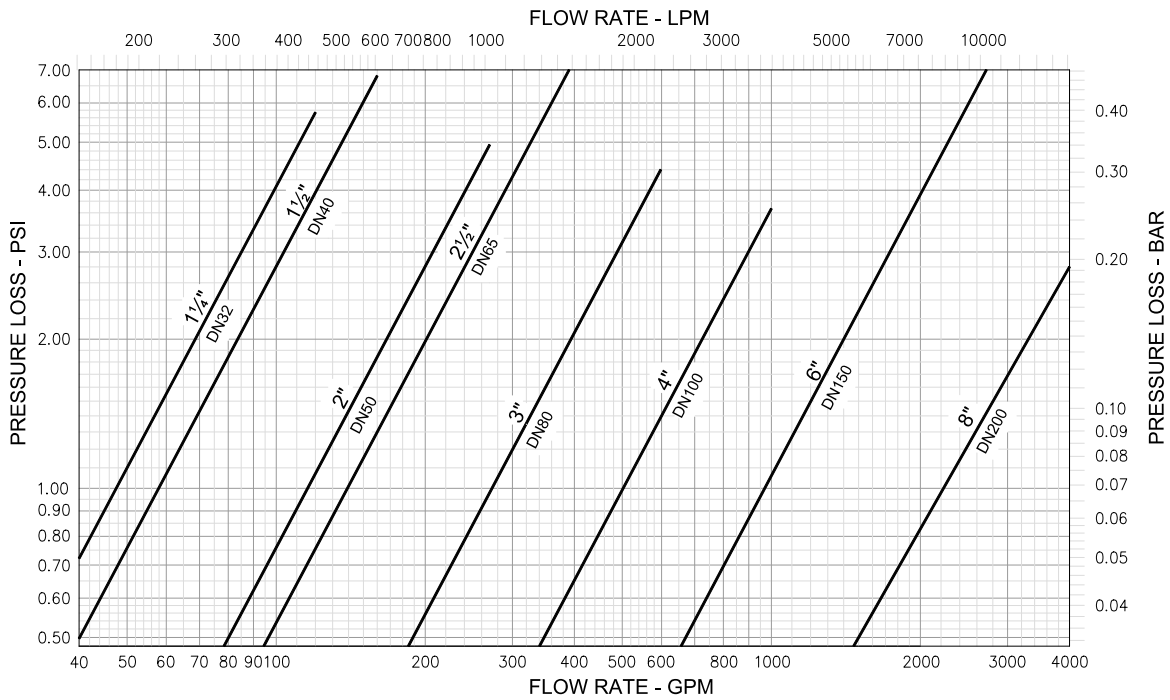

- UMC Equivalent Length of Piping for Friction Losses Through Schedule 40 Pipe**
- 1 1/4" = 6 feet**
 - 2 1/2" = 14 feet**
 - 6" = 30 feet**
 - 1 1/2" = 9 feet**
 - 3" = 11 feet**
 - 8" = 23 feet**
 - 2" = 8 feet**
 - 4" = 14 feet**

FIGURE 4: MODEL UMC MANIFOLD CHECK (WITHOUT BFV) FRICTION LOSS CURVES 1 1/4" TO 8"

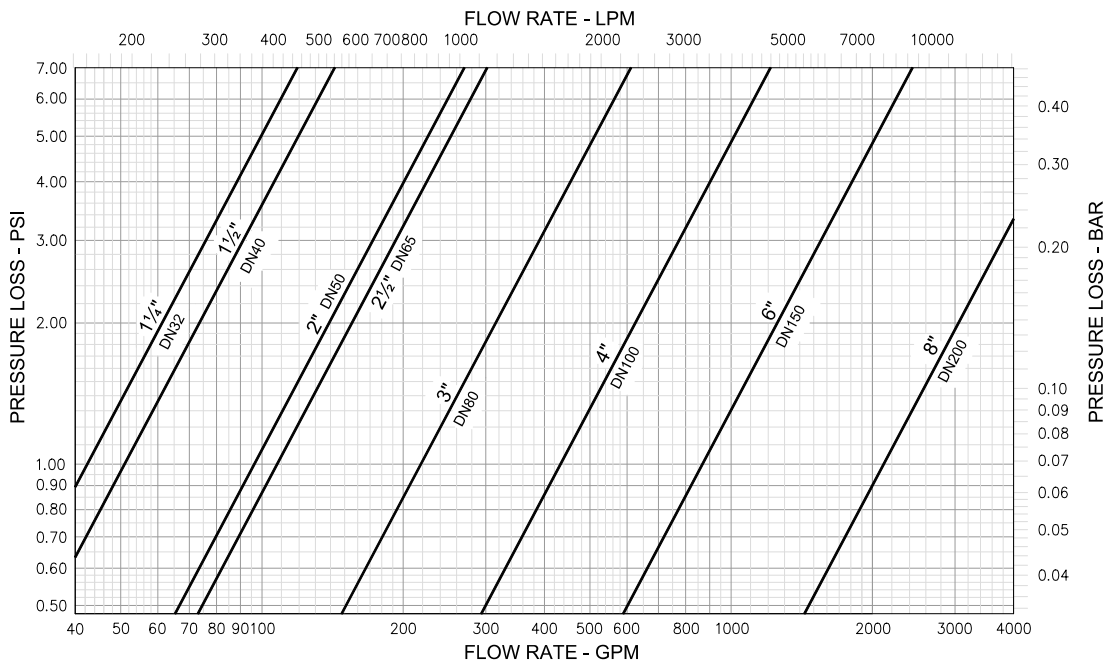

- UMC Equivalent Length of Piping for Friction Losses Through Schedule 40 Pipe**
- 1 1/4" = 8 feet**
 - 2 1/2" = 22 feet**
 - 6" = 38 feet**
 - 1 1/2" = 11 feet**
 - 3" = 17.5 feet**
 - 8" = 27 feet**
 - 2" = 12 feet**
 - 4" = 18.5 feet**

FIGURE 5: MODEL UMC MANIFOLD CHECK (WITH BFV) ASSEMBLY FRICTION LOSS CURVES 1 1/4" TO 8"

TABLE I: MODEL UMC AND BUTTERFLY VALVE END TO END DIMENSIONS

Size	Butterfly Valve Model	Butterfly Control Valve End to End Dimension inches (mm)	End to End Dimension <u>Without</u> Butterfly Control Valve inches (mm)	End to End Dimension <u>With</u> Butterfly Control Valve inches (mm)
1 1/4" MT x FT	GL300T	2.64 (67.9)	10.75 (273)	12.89 (327)
1 1/4" G x G	GL300G	4 (101.6)	11.4 (290)	15.4 (391)
	SERIES 728	7.25 (184)		18.65 (474)
1 1/2" MT x FT	GL300T	2.87 (73)	10.75 (273)	13.12 (333)
1 1/2" G x G	GL300G	4.1 (104)	11.4 (290)	15.5 (394)
	SERIES 728	7.25 (184)		18.65 (474)
2" G x G	GL300G	4.49 (114)	10 (254)	14.49 (368)
	SERIES 705	4.25 (108.0)		14.25 (362)
2 1/2" G x G	GL300G	4.49 (114)	10.63 (270)	15.12 (384)
	SERIES 705	3.77 (95.8)		14.4 (365.8)
65 mm G x G	GL300G	4.49 (114)	10.63 (270)	15.12 (384)
	SERIES 705	3.77 (95.8)		14.4 (365.8)
3" G x G	GLR300G	3.8 (96.4)	12.75 (324)	16.55 (420)
	SERIES 705	3.77 (95.8)		16.52 (419.6)
4" G x G	GLR300G	4.5 (115.4)	14.63 (371)	19.13 (486)
	SERIES 705	4.63 (117.6)		19.26 (488.6)
6" G x G	GLR300G	5.2 (132.4)	17.44 (443)	22.64 (575)
	SERIES 705	5.88 (149.4)		23.32 (592.4)
150 mm G x G	GLR300G	5.2 (132.4)	17.44 (443)	22.64 (575)
	SERIES 705	5.88 (149.4)		23.32 (592.4)
8" G x G	SERIES 705	5.33 (135.4)	27.0 (685.4)	32.71 (830.4)

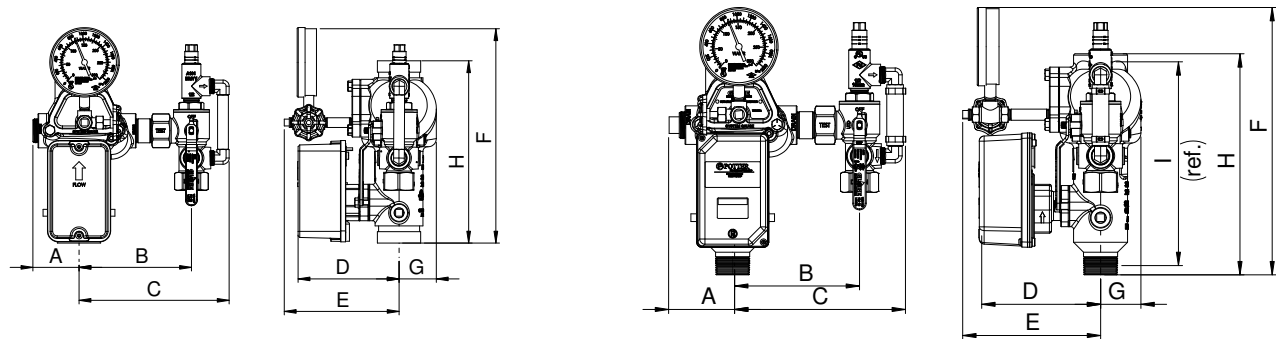

SIZE	A Inches (mm)	B Inches (mm)	C Inches (mm)	D Inches (mm)	E Inches (mm)	F Inches (mm)	G Inches (mm)	H Inches (mm)	I Inches (mm)
1 1/4" TXT	3.1 (79)	6.2 (157)	8.4 (214)	6 (150)	6.7 (170)	13 (328)	2 (50)	10.7 (272)	9.5 (241)
1 1/4" GXG	3.1 (79)	6.2 (157)	8.4 (214)	6 (150)	6.7 (170)	11.9 (301)	2 (50)	11.4 (290)	—
1 1/2" TXT	3.1 (79)	6.2 (157)	8.4 (214)	6 (150)	6.7 (170)	13 (328)	2 (50)	10.7 (272)	9.5 (241)
1 1/2" GXG	3.1 (79)	6.2 (157)	8.4 (214)	6 (150)	6.7 (170)	11.9 (301)	2 (50)	11.4 (290)	—
2"	3.9 (99)	5.4 (136)	7.6 (193)	6 (150)	6.8 (173)	11.9 (301)	2.1 (53)	10 (254)	—
2 1/2"	3.3 (84)	6.7 (171)	9.2 (233)	6.2 (157)	7.2 (182)	12.3 (312)	2.3 (58)	10.6 (269)	—
76.1 mm	3.3 (84)	6.7 (171)	9.2 (233)	6.2 (157)	7.2 (182)	12.3 (312)	2.3 (58)	10.6 (269)	—

**FIGURE 6: MODEL UMC ASSEMBLY WITHOUT BFV
DIMENSIONAL DRAWING FOR SIZES 1 1/4" TO 2 1/2"**

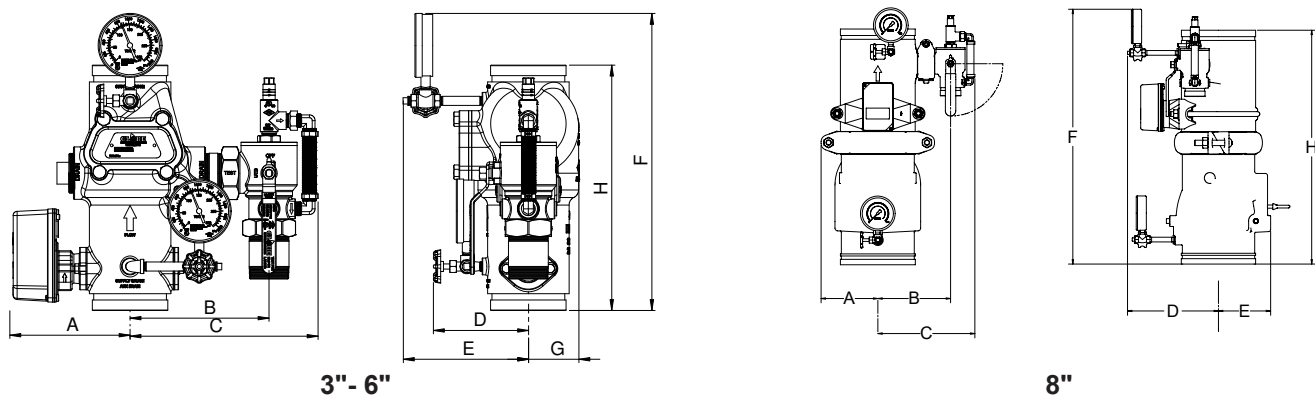

SIZE	A inches (mm)	B inches (mm)	C inches (mm)	D inches (mm)	E inches (mm)	F inches (mm)	G inches (mm)	H inches (mm)
3"	6.5 (165)	6.9 (176)	9.4 (238)	—	6.4 (161)	16 (406)	2.4 (61)	12.7 (324)
4"	7 (177)	8.3 (210)	11.2 (284)	5.6 (143)	7 (178)	17.7 (449)	3 (76)	14.6 (371)
6"	8 (203)	9.5 (241)	12.4 (315)	6.4 (163)	7.9 (201)	19.9 (504)	3.9 (99)	17.5 (444)
165.1 mm	8 (203)	9.5 (241)	12.4 (315)	6.4 (163)	7.9 (201)	19.9 (504)	3.9 (99)	17.5 (444)
8"	6.5 (165)	8.38 (213)	11.25 (286)	10.6 (269)	6.0 (152)	29.62 (752)	NA	27.18 (690)

**FIGURE 7: MODEL UMC ASSEMBLY WITHOUT BFV
DIMENSIONAL DRAWING FOR SIZES 3" TO 8"**

FLOW SWITCH REQUIREMENTS

The Model UMC Floor Control/ Shotgun Riser assembly is sold inclusive of a Potter VSR flow switch. The flow switch utilizes exactly the same electrical and switch components as the Potter VSR flow switch but includes an adapter which attaches directly to the Model UMC Manifold Check assembly. This adapter has been tested as part of the UMC assembly to ensure the hydrostatic strength as well as the placement and sensitivity of the paddle is within the criteria set forth by UL and FM.

The part number for the flow switch assembly can be found

in the replacement parts section of the technical literature.

The Potter VSR Flow switch includes 2 sets of switches, one set can be used to activate the central fire alarm system while the other set can be utilized to activate a local alarm (if necessary). See figure 8 for a typical wiring diagram for the Model VSR Flow switch.

Note: For more information on the flow switch see www.pottersignal.com.

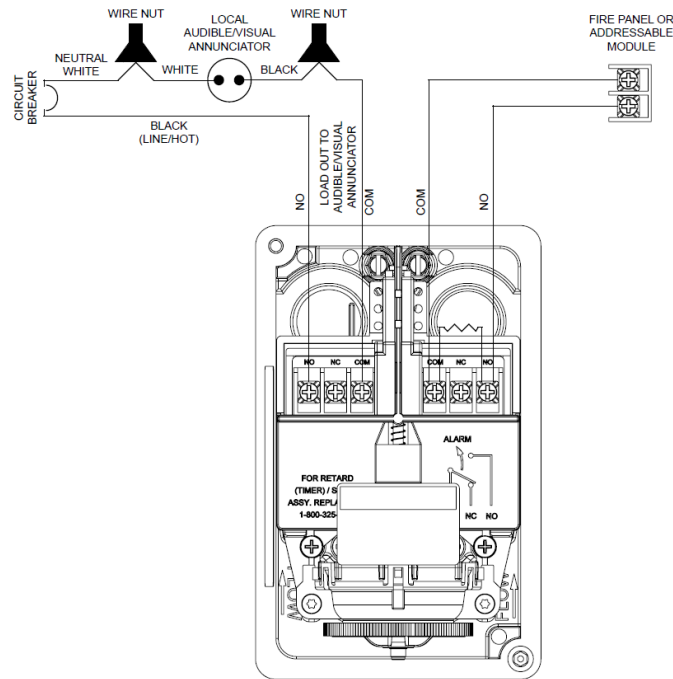
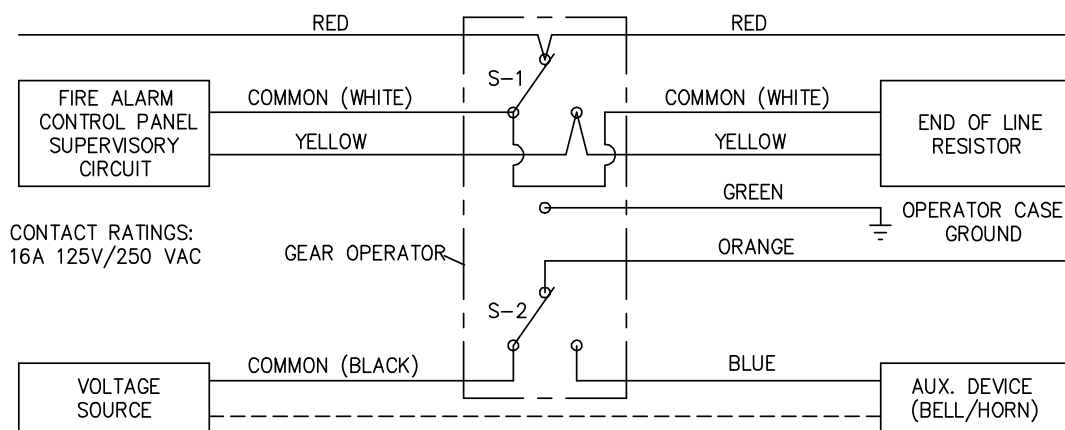

FIGURE 8: MODEL VSR-M FLOW SWITCH TYPICAL WIRING DIAGRAM



VALVE WIRING SHOWN WITH VALVE IN OPEN POSITION

FIGURE 9: GL300T, GL300G, AND GLR300G BUTTERFLY VALVE WIRING DIAGRAM

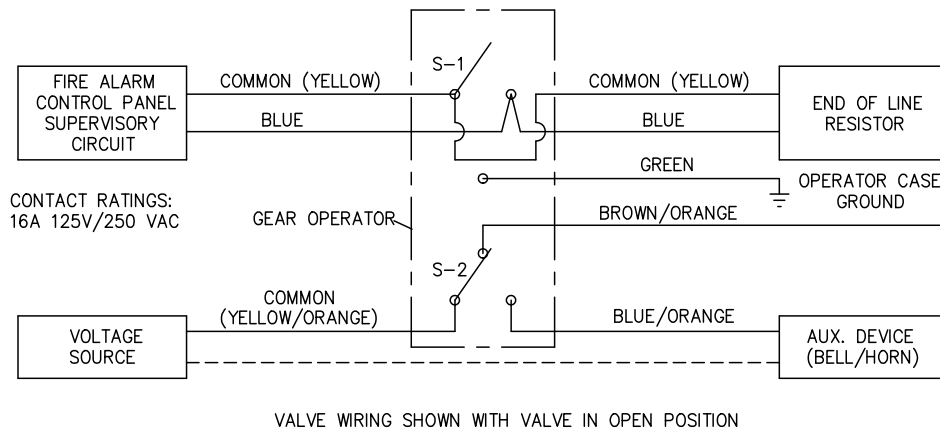

FIGURE 10:SERIES 728 AND 705 BUTTERFLY VALVE WIRING DIAGRAM

SWITCH AND WIRING

1. The supervisory switch contains two single pole, double throw, prewired switches.
2. Switches are rated:
 - 10 amps @ 125 or 250 VAC/60 Hz
 - 0.50 amps @ 125 VDC
 - 0.25 amps @ 250 VDC
3. Switches supervise the valve in the "OPEN" position.
4. One switch has two #18 insulated wires per terminal, which permit complete supervision of leads (refer to diagrams and notes below). The second switch has one #18 insulated wire per terminal. This double circuit provides flexibility to operate two electrical devices at separate locations, such as an indicating light and an audible alarm, in the area that the valve is installed.
5. A #14 insulated ground lead (green) is provided.

Switch #1 = S1

For connection to the supervisory circuit of a UL Listed alarm control panel

Switch #2 = S2

Auxiliary switch that may be connected to auxiliary devices, per the authority having jurisdiction

S1 { Normally Closed: (2) Blue
Common: (2) Yellow

S2 { Normally Closed: Blue with Orange Stripe
Normally Open: Brown with Orange Stripe
Common: Yellow with Orange Stripe

INSTALLATION

The Model UMC Floor Control/ Shotgun Riser assembly is sold as a complete unit, assembled and shipped in a single box.

The Model UMC Manifold Check Valve must be installed in an accessible and visible location, which is maintained at or above a minimum temperature of 40°F (4°C). The UMC may be installed in the horizontal or vertical (flow upward) orientation.

All valves must be installed in accordance with the appropriate installation standard (i.e. NFPA 13 or other). All electrical connections must be made per the applicable installation standard and/or the National Electric Code (i.e. NFPA 70, NFPA 72 or other).

Proper hydrostatic test procedure must be followed per NFPA 13.

It is not necessary to remove the ARV Relief Valve prior to system hydrostatic test. The Adjustable ARV may simply be temporarily adjusted to a pressure above the test pressure during the hydrostatic test. Be sure to return the ARV Relief Valve to its normal setting after the completion of the hydrostatic test.

MODEL ARV RELIEF VALVE SETTING PROCEDURE

The Globe 1/2 inch Model ARV, 300 psi Adjustable Pressure Relief Valve, is factory set to relieve at a pressure of approximately 175 psi (12 bar).

The Pressure Relief Valve may be reset to a higher pressure; however, it must be reset to relieve at a pressure which is in accordance with the requirements of the authority having jurisdiction, typically nominal 10 psi (.7 bar) above the expected normal system pressure.

To reset the Model ARV pressure relief valve, use an adjustable crescent wrench, to turn the hex cap clockwise for a higher pressure setting or counter-clockwise for a lower pressure setting. Use the calibrated lines on the stem for an approximate relief pressure setting. 1 full turn of the hex cap will result in approximately 25 psi increase or decrease.

To verify the new setting, isolate the Model ARV relief valve and use a small hydrostatic pump attached to the supply. Increase the pressure at the relief valve to 10 psi above the expected normal system pressure. Readjust the ARV as needed to maintain a 10 psi higher relief setting.

TESTING

Reference NFPA 25, Standard for the Inspection, Testing and Maintenance of Water-Based Fire Protection Systems.

Before proceeding with any tests involving water flow, the following precautions need to be taken:

- STEP 1.** Check the location where the test connection discharges to make sure that all is clear and that there is no possibility of the water flow causing damage or injury.
- STEP 2.** Check the end of the test connection to make sure that it is unobstructed. To achieve a satisfactory test, there must be an unrestricted flow of water when the test valve is wide open.
- STEP 3.** Check for alarm connections to a central station or fire department. If such connections are found, give proper notice to the signal receiving station before proceeding with the test.

Note: A main drain test may also operate local fire alarms unless they are temporarily disabled.

MAINTENANCE

The owner is responsible for the Inspection, Testing and Maintenance of their fire protection system.

System inspection, testing and maintenance shall be performed in accordance with this section as well as NFPA 25 or other applicable Standard to insure the integrity of the entire system, including alarm functions as well as other system components. Any impairments must be immediately corrected.

Before closing a system main control valve for maintenance work on the fire protection system, obtain permission to shut down the affected fire protection system from the proper authorities and notify all personnel who may be affected.

Note:

All valves should be carefully inspected, tested, and maintained in accordance with NFPA 25 or other applicable Standard.

It is important to ensure a clean water supply free of debris and solid particles such as sand, gravel, or mud.

If, during an inspection of a water control valve, sediment or free particles of matter are noted, a further examination of internal valve parts is necessary.

All deposits should be removed from all operating parts and ports.

Where difficulty in performance is experienced, the manufacturer or its authorized representative shall be contacted before any field adjustment is to be made.

UMC Clapper Facing. The rubber clapper facing should be checked for wear or damage and to determine that it is free of dirt and other foreign substances. If found to be worn or damaged (e.g., foreign matter embedded in the surface; cut or torn facing), the facing should be replaced. If it is dirty, it should be cleaned. Compounds which could damage the rubber facing must never be used. Should clapper facing replacement become necessary, the following steps should be performed;

Note: Before performing the following steps, insure that the system has been depressurized and drained.

Clapper Removal

- STEP 1.** Remove handhole cover.
- STEP 2.** Remove hinge pin plugs from front and back of UMC.
- STEP 3.** Using allen wrench, push hinge pin from back of UMC towards front.

STEP 4. Once hinge pin is accessible, carefully grab with pliers or similar to pull hinge pin out of body.

Note: Care must be taken to confine clapper spring while extracting hinge pin from body. Spring is under tension around hinge pin. It is also recommended to cover drain port to minimize the possibility of spring inadvertently dropping into drain piping.

STEP 5. Carefully remove clapper assembly from UMC.

Clapper Replacement. When replacing clapper, be sure clapper spring has been properly positioned around hinge pin such that tension is applied to the clapper by the spring.

Seat Ring. The seat ring should be checked for nicks and for stones, dirt or other foreign matter. It should be cleaned thoroughly. If the seat ring is found to be damaged, UMC should be replaced.

Water Flow Switch (VSR-M). There is no maintenance required, only periodic testing and inspection. Should switch be found to be malfunctioning, refer to Potter Signal Technical Literature for guidance.

Model ARV Adjustable Relief Valve. Valve is not field serviceable. If inadvertent leakage is observed, first test the pressure setting utilizing the procedure outlined in the ARV Relief Valve Setting Procedure. If valve does not respond to field adjustments, valve shall be replaced.

Note:

Visual calibration lines on valve are used for approximate adjustment. Verify pressure setting with pressure gauge.

Model UTD Universal Test & Drain Valve: The Globe Model UTD Universal Test and Drain Valve does not require any regularly scheduled maintenance. The UTD is not field serviceable.

ORDERING INFORMATION

MODEL UMC UNIVERSAL MANIFOLD CHECK VALVE ASSEMBLY

Specify: MODEL UMC MANIFOLD CHECK VALVE ASSEMBLY, SIZE (1¼", 1½", 2", 2½", 76.1 mm, 3", 4", 6", 165.1 mm, 8") PN (see Part Number in Table A-G)

Note:

Control Valve Model based on availability at time of order. See appropriate Tables for end-to-end dimensional information.

REPLACEMENT PARTS

MODEL UMC UNIVERSAL MANIFOLD CHECK VALVE REPLACEMENT PARTS/KITS

VSR-M FLOW SWITCH with ADAPTER (includes gasket)

SIZE	PART NUMBER
1¼" - 2"	91144802-A-G
2½"	91144825-A-G
3"	91144803-A-G
4"	91144804-A-G
6"	91144806-A-G
8"	91144808-A-G

MODEL UTD TEST AND DRAIN

(SEE GFV-570 for more information)

Specify: MODEL UTD TEST AND DRAIN WITH RELIEF VALVE, SIZE (1", 1¼", or 2") PN:

SIZE	PART NUMBER
1" (DN25)	S010UTDGA0
1¼"(DN32).	S012UTDGA0
2" (DN50).	S020UTDGA4

Specify: MODEL UTD TEST AND DRAIN, SIZE (1", 1¼", or 2") PN:

SIZE	PART NUMBER
1" (DN25).	S010UTDGA0
1¼"(DN32).	S012UTDGA0
2" (DN50).	S020UTDGA4

MODEL ARV RELIEF VALVE

(SEE Victaulic 30.74 for more information)

Specify: MODEL ARV 1/2" ADJ RELIEF VALVE PN.

..... P0047470PR

Note:

300 psi (20.6 Bars) Pressure Gauges Standard (600 psi (41.2 Bars) Ordered Separately

PN 300121-D

GLOBE® PRODUCT WARRANTY

Globe agrees to repair or replace any of its manufactured products found to be defective in material or workmanship for a period of one year from date of shipment.

For specific details of our warranty please refer to Price List Terms and Conditions of Sale (Our Price List).

