



Features – PVC, CPVC & PP

Designed for optimum flow, quick response and positive shutoff with minimum turbulence, this industrial grade Swing Check Valve is used in a variety of industrial and chemical processing applications where high volume fluid transfer is required. Suitable for horizontal or up-flow vertical applications. Available in PVC, CPVC and Glass Filled Polypropylene, IPS 3/4" - 8" with Flanged Body.

Engineered for Quick Response, Full-Flow Fluid Transfer

- Heavy Bodied All-Plastic Interior Construction
- Top Access & O-ring Sealed Drain Plug for In-line Servicing
- Standard O-ring type Seat & Seals in EPDM or FKM
- Sizes 3/4" - 4" Pressure Rated to 150 psi @ 73°F, 6" Pressure Rated to 100 psi and 8" to 70 psi @ 73°F
- Stainless Steel External Hardware
- Fully Serviceable, Replaceable Components
- Suitable for Vacuum Service
- Assembled with Silicone-Free, Water Soluble Lubricants

Sample Engineering Specification

All thermoplastic check valves shall be flanged Swing Check type constructed from PVC Type I, ASTM D 1784 Cell Classification 12454 or CPVC Type IV, ASTM D 1784 Cell Classification 23447, or Polypropylene, ASTM D 4101. All O-rings shall be EPDM or FKM. All valves components shall be replaceable. All valves shall have top-entry access with O-ring sealed drain plug for in-line servicing. All valves shall have optional external Arrow Position Indicator or optional external Counter Balance. All 3/4" - 4" valves shall be pressure rated to 150 psi, all 6" valves to 100 psi, and all 8" valves to 70 psi for water at 73°F, as manufactured by Spears® Manufacturing Company.

Options & Accessories

- External Arrow Position Indicator¹
- External Counter Balance¹
- Natural Polypropylene Body

1: Available as assembled valve or kit for installed valve

Quick-View Valve Selection Chart

Valve Size	O-ring Material	Part Number ^{1,2,3}	Pressure Rating
3/4	EPDM	4423-007	150 psi Non-Shock Water @ 73°F
	FKM	4433-007	
1	EPDM	4423-010	
	FKM	4433-010	
1-1/4	EPDM	4423-012	
	FKM	4433-012	
1-1/2	EPDM	4423-015	
	FKM	4433-015	
2	EPDM	4423-020	
	FKM	4433-020	
2-1/2	EPDM	4423-025	
	FKM	4433-025	
3	EPDM	4423-030	
	FKM	4433-030	
4	EPDM	4423-040	
	FKM	4433-040	
6	EPDM	4423-060	100 psi @ 73°F
	FKM	4433-060	
8	EPDM	4423-080	70 psi @ 73°F
	FKM	4433-080	

1: For CPVC valves, add the letter "C" to part numbers listed (e.g. 4423-025C).

2: For valve with Arrow Position Indicator, add the letter "I" before the dash separator (e.g., 4423I-025).

3: For Polypropylene valves, add the letter "P" to the part number (e.g. 4423-025P).

General Installation Information: Industrial Swing check valves are designed for horizontal installations, but may be installed in up-flow only vertical position. Check valves should be installed a minimum of ten (10) pipe diameters from pump or other sources of turbulence. Check valves **MUST** be installed with the valves **FLOW** arrow pointing in the direction of flow. Do not install valve upside down. Normal flange-bolt assembly in top holes of the valve flange requires bolt insertion through the companion flange with nuts secured on Swing Check flange side. Certain system configurations involving direct connection of a Swing Check Valve to other flanged equipment may require consideration of this bolt clearance.



Valves Product Guide & Engineering Specifications

Industrial Swing Check Valves

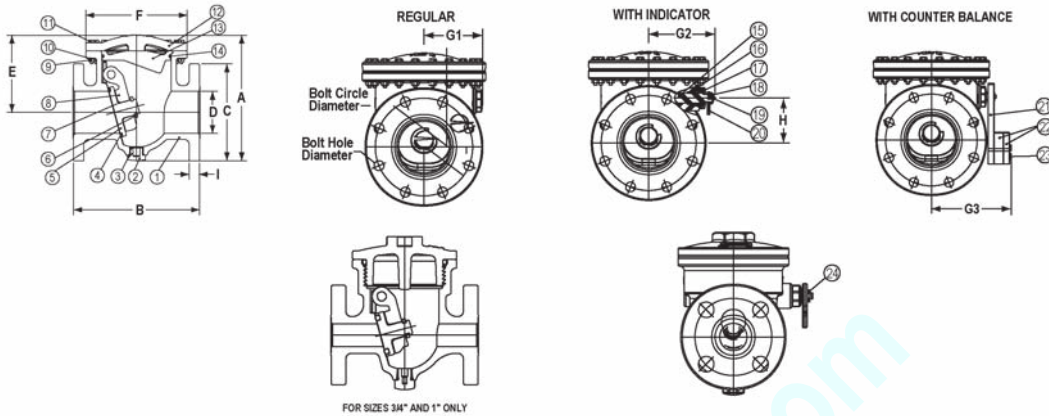

Replacement Parts

No.	Component	Qty.	Material
1	Body	1	PVC/CPVC/PP
2	Plug	1	PVC/CPVC/PP
3	Plug O-ring	1	EPDM/FKM
4	Disc O-ring A	1	EPDM/FKM
5	Disc	1	PVC/CPVC/PP
6	Disc Ret. Clip	1	PP
7	Disc O-ring B	1	EPDM/FKM
8	Swing Arm	1	PVC/CPVC/PP
9	Nut	12-30	SS 316
10	Washer	24-60	SS 316
11	Bolt	12-30	SS 316
12	Bonnet	1	PVC/CPVC/PP

No.	Component	Qty.	Material
13	Seal Carrier	1	PVC/CPVC/PP
14	Body O-ring	1	EPDM/FKM
15	Arm Pin	1	PVC/CPVC/PP
16	Arm Pin Seal	2	FKM
17	Arm Pin Plug	1	PVC/CPVC/PP
18	Arm Pin Washer	1	SS 316
19	Arm Pin Bolt	1	SS 316
20	Indicator	1	PP
21	Counterbalance	1	PVC
22	Weight Block	1	PVC
23	Weight Block Bolt	2	SS 316
24	Arm Pin Ret. Clip	1	PP

Dimensions & Weights

Nominal Size	A	B	C	D	E	F	G1	G2	G3	H	I	Approx. Wt (Lbs.)	
												PVC	CPVC
3/4	5-5/16	5-1/2	3-7/8	3/4	3-3/4	3-3/4	2-1/2	3	4	1-7/16	1/2	1.72	1.80
1	6-5/8	6-5/16	4-1/4	31/32	4-1/2	4-1/2	2-25/32	3-7/32	4-7/32	1-21/32	5/8	2.62	2.80
1-1/4	7-3/8	7-3/32	5	1-19/32	4-9/16	5-3/4	3-3/16	3-25/32	4-3/8	1-27/32	23/32	4.61	4.87
1-1/2	7-3/8	7-3/32	5	1-19/32	4-9/16	5-3/4	3-3/16	3-25/32	4-3/8	1-27/32	23/32	4.61	4.87
2	8-1/2	7-7/8	6	2	5-1/4	7	3-9/16	4-1/8	4-23/32	2-29/32	13/16	6.99	7.24
2-1/2	10-3/4	10-1/4	7-1/2	3-1/8	6-3/4	8-5/8	4-1/4	5	6-9/32	3-1/16	7/8	14.77	15.74
3	10-3/4	10-1/4	7-1/2	3-1/8	6-3/4	8-5/8	4-1/4	5	6-9/32	3-1/16	7/8	14.77	15.74
4	11-3/4	11-13/16	9	3-29/32	7-1/4	9-1/2	4-1/2	5-1/4	6-17/32	3-17/32	31/32	18.37	19.78
6	15-5/8	15-1/4	11	5-7/8	9-1/2	13-7/16	6	6-3/4	8-1/32	5-1/32	1	42.64	44.56
8	19-1/8	19-23/32	13-1/2	7-7/8	11-5/8	16-5/16	7	7-3/4	9-1/32	6-1/2	1-5/32	68.85	76.05

Cv Values

Valve Size	Cv ¹
3/4	18
1	24
1-1/4	70
1-1/2	70
2	95
2-1/2	300
3	300
4	480
6	1100
8	1900

¹: Gallons per minute at 1 psi pressure drop.

Nominal Size	Bolt Circle Diameter	Bolt Hole Diameter	Number of Bolt Holes
3/4	2-3/4	5/8	4
1	3-1/8	5/8	4
1-1/4	3-1/2	5/8	4
1-1/2	3-7/8	5/8	4
2	4-3/4	3/4	4
2-1/2	5-1/2	3/4	4
3	6	3/4	4
4	7-1/2	3/4	8
6	9-1/2	7/8	8
8	11-3/4	7/8	8



Temperature Pressure Rating

System Operating Temperature °F (°C)		100 (38)	110 (43)	120 (49)	130 (54)	140 (60)	150 (66)	160 (71)	170 (77)	180 (82)	190 (88)	200 (93)	210 (99)	
Valve Pressure Rating psi (MPa)	3/4" – 4"	PVC	150 (1.03)	135 (.93)	110 (.76)	75 (.52)	50 (.34)	-0-	-0-	-0-	-0-	-0-	-0-	-0-
		CPVC	150 (1.03)	140 (.97)	130 (.90)	120 (.83)	110 (.76)	100 (.70)	90 (.62)	80 (.55)	70 (.48)	60 (.41)	50 (.34)	-0-
		PP	150 (1.03)	105 (.72)	90 (.62)	80 (.55)	75 (.52)	65 (.45)	55 (.38)	50 (.34)	45 (.31)	-0-	-0-	-0-
	6"	PVC	100 (.70)	90 (.62)	80 (.55)	65 (.38)	50 (.34)	-0-	-0-	-0-	-0-	-0-	-0-	-0-
		CPVC	100 (.70)	95 (.66)	90 (.62)	85 (.59)	80 (.55)	75 (.52)	70 (.48)	65 (.45)	60 (.41)	55 (.38)	50 (.34)	-0-
		PP	100 (.70)	90 (.62)	85 (.59)	75 (.52)	70 (.48)	60 (.41)	55 (.38)	50 (.34)	45 (.31)	-0-	-0-	-0-
	8"	PVC	70 (.48)	65 (.45)	60 (.41)	50 (.34)	45 (.31)	-0-	-0-	-0-	-0-	-0-	-0-	-0-
		CPVC	70 (.48)	65 (.45)	62 (.43)	60 (.41)	57 (.39)	55 (.38)	52 (.36)	50 (.34)	45 (.31)	42 (.29)	40 (.28)	-0-
		PP	70 (.48)	60 (.41)	57 (.39)	55 (.38)	52 (.36)	50 (.34)	47 (.32)	45 (.31)	40 (.28)	-0-	-0-	-0-

Arrow Position Indicator Kit

Spears® Swing Check Valve Indicator Kit is designed for field installation of external Indicator Arrow in Spears® Swing Check Valves. This kit can be installed through the bonnet assembly and removal of valve from line is not required.

Kit Includes:

- 1 - Extended Shaft
- 2 - Shaft Cup Seals
- 1 - Shaft Nut
- 1 - Indicator Arrow
- 1 - Retaining clip

Valve Size	Part Numbers		
	PVC Kit	CPVC Kit	PP Kit
3/4	I3K-007	I3K-007C	I3K-007P
1	I3K-010	I3K-010C	I3K-010P
1-1/4 & 1-1/2	I3K-015	I3K-015C	I3K-015P
2	I3K-020	I3K-020C	I3K-020P
2-1/2 & 3	I3K-030	I3K-030C	I3K-030P
4	I3K-040	I3K-040C	I3K-040P
6	I3K-060	I3K-060C	I3K-060P
8	I3K-080	I3K-080C	I3K-080P

Application of Counter Balance

Swing Check Valves operate in response to a fluid stream flow opening a swinging disc. As the fluid stream slows and reverses, the disc responds by swinging to the closed position. Sudden reversal of flow direction can result in “slamming” condition as the disc closes. The function of the Counter Balance mechanism is to start the disc closing earlier as the fluid stream begins to slow so that it is almost closed when flow reversal takes place, thereby eliminating slamming of the disc. Available as installed unit with valve or as a kit for adaptation of installed valves.

Counter Balance Kits

Spears® Swing Check Valve Counter Balance Kit is designed for field installation of counter balance mechanism in Spears® Swing Check Valves. This kit can be installed through the bonnet assembly and removal of valve from line is not required.

Kit Includes:

- 1 - Extended Shaft
- 2 - Shaft Cup Seals
- 1 - Shaft Nut
- 1 - Counter Balance
- 1 - Retaining Bolt
- 1 - Flat Washer
- 1 - Extra Weight Plates (1-small & 1-large)
- 1 - Plate Mounting Bolts (2-long & 2 short).

Valve Size	Part Numbers		
	PVC Kit	CPVC Kit	PP Kit
3/4	CB3K-007	CB3K-007C	CB3K-007P
1	CB3K-010	CB3K-010C	CB3K-010P
1-1/4 & 1-1/2	CB3K-015	CB3K-015C	CB3K-015P
2	CB3K-020	CB3K-020C	CB3K-020P
2-1/2 & 3	CB3K-030	CB3K-030C	CB3K-030P
4	CB3K-040	CB3K-040C	CB3K-040P
6	CB3K-060	CB3K-060C	CB3K-060P
8	CB3K-080	CB3K-080C	CB3K-080P