

Brass Ball Valves

Two-Piece Body • Full Port • Blowout-Proof Stem • PTFE Seats • w/ Drain

600 PSI/41.4 Bar Non-Shock Cold Working Pressure

MATERIAL LIST

PART	SPECIFICATION
1. Body	Forged Brass ¹ CU > 57%
2. End Cap	Forged Brass ¹ CU > 57%
3. Ball Seat	PTFE
4. Ball	Brass, Chrome Plated
5. Stem	Brass
6. Stem Packing	PTFE
7. Packing Nut	Brass
8. Lever Handle	Steel, Plated
9. Handle Nut	Stainless Steel
10. Drainable Cap	Brass
11. Rubber Seat	Silicone

Note: ¹ For Material Certification, contact NIBCO Technical Services.



S-FP-600-AD
Solder

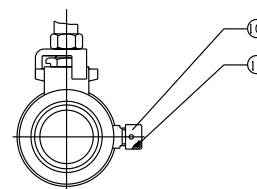
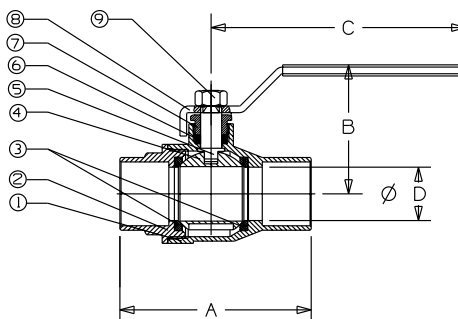

S-FP-600-AD
C x C

DIMENSIONS—WEIGHTS—QUANTITIES

Size	Dimensions								Weight			
	A		B		C		D		Lbs.	Kg.	Ctn Qty.	
In. mm.	In.	mm.	In.	mm.	In.	mm.	In.	mm.				
½	15	2.16	55	1.67	42	3.54	90	.58	15	.54	.24	20
¾	20	2.85	72	2.03	52	4.47	114	.75	19	.76	.34	12
1	25	3.38	86	2.24	57	4.47	114	.95	24	1.07	.49	6

WARNING: This product can expose you to chemicals including lead, which is known to the State of California to cause cancer and birth defects or other reproductive harm. For more information go to www.P65Warnings.ca.gov.

NOT FOR USE WITH POTABLE DRINKING WATER APPLICATIONS AFTER JANUARY 3, 2014.