

Bronze Ball Valves

Two-Piece Body • Full Port 1/4"-1" • Conventional Port 1 1/4"-3" •
Bronze Trim • Blowout-Proof Stem

600 PSI/41.4 bar non-shock cold working pressure
150 PSI/10.3 bar saturated steam*

CONFORMS TO MSS SP-110

MATERIAL LIST

PART	SPECIFICATION
1. Handle Nut	Zinc Plated Steel
2. Handle	Zinc Plated Steel Clear Chromate Plastisol Coated
3. Threaded Pack Gland	Brass ASTM B 16 Alloy C36000
4. Packing	PTFE
5. Stem	Silicon Bronze ASTM B 371 Alloy C69430 or ASTM B 99 Alloy C65100
6. Thrust Washer	Reinforced PTFE
7. Ball	Brass ASTM B 124 Alloy C37700 or ASTM B16 Alloy C36000 EACH with Hard Chrome Plate
8. Seat Ring (2)	Reinforced PTFE
9. Body	Cast Red Bronze ASTM B 584 Alloy C84400
10. Body End Piece	Cast Red Bronze ASTM B 584 Alloy C84400

1/4" size only has a 304 stainless steel grounding washer.

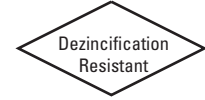

T-580-70
Threaded



S-580-70
Solder

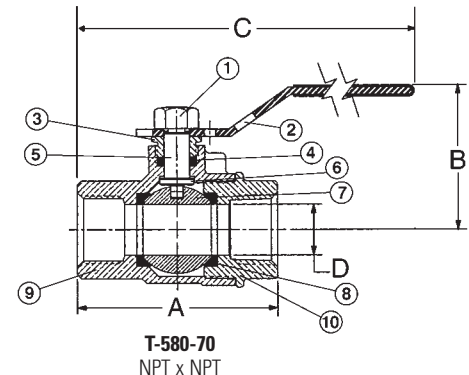
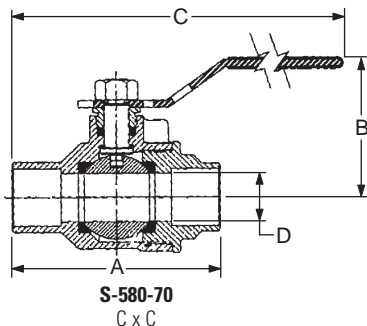

DIMENSIONS—WEIGHTS—QUANTITIES

Size	Dimensions				D	T-580-70		S-580-70		Master Ctn. Qty.								
	A	B	C	C		Lbs.	Kg.	Lbs.	Kg.									
† 1/4	8	2.00	51	1.75	44	1.75	44	5.00	127	4.75	121	.38	10	.45	.21	.42	.19	100
† 3/8	10	2.00	51	1.84	47	1.75	44	5.00	127	4.81	122	.38	10	.45	.21	.42	.19	100
† 1/2	15	2.44	62	2.56	65	1.88	48	5.19	132	5.25	133	.50	13	.64	.29	.60	.27	100
† 3/4	20	2.94	75	3.25	83	2.25	57	6.25	159	6.25	159	.75	19	1.33	.60	1.27	.58	50
† 1	25	3.34	85	3.75	95	2.38	60	6.44	164	6.63	168	1.00	25	1.79	.81	1.72	.78	40
1 1/4	32	3.94	100	4.00	102	2.63	67	6.75	171	6.75	171	1.00	25	2.17	.98	1.78	.81	20
1 1/2	40	4.31	109	4.44	113	3.00	76	8.88	226	9.00	229	1.25	32	3.27	1.48	2.87	1.30	20
2	50	4.63	118	5.50	140	3.16	80	9.06	230	9.50	241	1.50	38	5.09	2.31	4.60	2.08	10
2 1/2	65	5.84	148	7.28	185	3.50	89	9.66	245	10.38	264	2.00	51	8.25	3.74	8.18	3.71	6
3	80	7.09	180	8.78	223	4.41	112	11.53	293	12.38	314	2.50	64	15.65	7.10	14.86	6.74	4

† NIBCO supplies full port T or S-585-70 on this size.

Note: solder end is designed to be soft-soldered into lines using solders with the melting point not exceeding 500°F. Higher temperature solders will damage the seat material. See installation sheet packaged with valves.

♦ For detailed operating pressure, refer to pressure temperature chart on page 42.



WARNING: This product can expose you to chemicals including lead, which is known to the State of California to cause cancer and birth defects or other reproductive harm. For more information go to www.P65Warnings.ca.gov.

*Weighted average lead content ≤ 0.25%

**LEAD FREE*
OPTION
AVAILABLE**

**OXYGEN
SERVICE
OPTION
AVAILABLE**

Visit our website for the most current information.