

高性能パイロット型電磁弁

High Quality, Long Life Type Solenoid Valve

2WAY

動作 (Operation) :
 通電時開型 (Normally Closed)
 通電時閉型 (Normally Open)

●大流量、中高圧ラインの制御に最適です。

●Best type for large quantity of flow & mid-high pressure control.

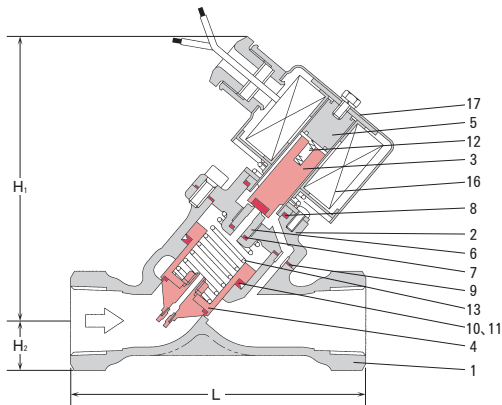

ネジ込み型 Screw Type

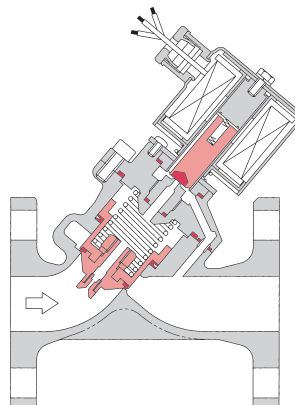

フランジ型 Flange Type

通電時開型 Normally Closed

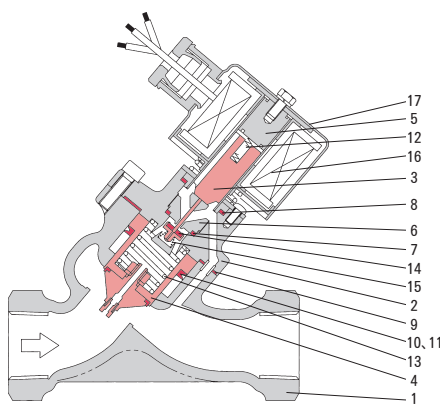

通電時閉型 Normally Open

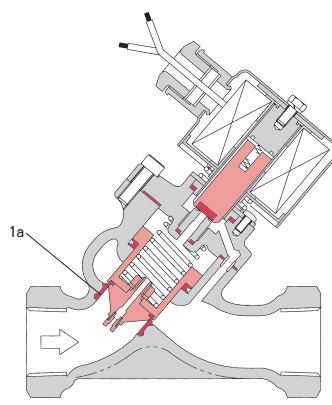

タフシート付 Stainless Seat

■ 主要部品表 Main Parts List

No.	名称 Name of Parts	材 質 Materials							
		通電時開型 Normally Closed				通電時閉型 Normally Open			
		常温用 10~25A	MAX60°C 32~80A	高温用 10~25A	MAX200°C 32~80A	常温用 10~25A	MAX60°C 32~80A	高温用 10~25A	MAX200°C 32~80A
1	ボデー Valve Body	CAC406							
1a	タフシート Stainless Seat	SUS304 ※							
2	バルブボンネット Valve Bonnet	CAC406							
3	プランジャー Plunger	SUS410+FKM		SUS410+PTFE		SUS410			
4	メインバルブAssy Main Valve Assy	SUS304+PTFE	CAC406+PTFE	SUS304+PTFE	CAC406+PTFE	SUS304+PTFE	CAC406+PTFE	SUS304+PTFE	CAC406+PTFE
5	バックレスAssy Packless Assy	SUS410+SUS304							
6	バイパスシート By-pass Seat	SUS304							
7	バイパスシートパッキン By-pass Seat Packing	NBR		PTFE		NBR		PTFE	
8	バックレスパッキン Packless Packing	NBR		PTFE		NBR		PTFE	
9	ボデーパッキン Body Packing	NBR		PTFE		NBR		PTFE	
10	Vリング VRing	FKM		-		FKM		-	
11	Kリング+リリーフスプリング KRing+Relieve Spring	-		PTFE+SUS304		-		PTFE+SUS304	
12	プランジャースプリング Plunger Spring	SUS304							
13	メインバルブスプリング Main Valve Spring	SUS304							
14	ニードルバルブAssy Needle Valve Assy	-				SUS304+FKM		SUS304+PTFE	
15	ニードルバルブスプリング Needle Valve Spring	-				SUS304			
16	コイル Coil	PEW							
17	コイルボンネット Coil Bonnet	SPC+塗装 (Coating)							

※ タフシートはタフシート付製品にのみ、ボデー弁座部に埋め込まれております。10~50Aまでの製作となります。

※ Stainless seat is embedded in the valve seat of the body only for the product with the Stainless seat. And the available size is from 10A to 50A.

■ 共通仕様 Common Specification

項目 Item	内容 Description				
流体 Fluid	水 Water	油 Oil	空気 Air	ガス Gas	蒸気 Steam
流体温度 Fluid Temperature	MAX60°C			MAX200°C	
電源 Power Source	AC100V 50/60Hz, AC110V 60Hz or AC200V 50/60Hz, AC220V 60Hz				
絶縁種別 Class	F class		H class		
流体粘度 Fluid Viscosity	50mm ² /s (50cst)				
取付姿勢 Installation	鉛直±90° A Coil Vertical ±90°				
動作 Operation	通電時開型 or 通電時閉型 Normally Closed or Normally Open ※				
周囲温度・湿度 Ambient Temp./Humidity	0~50°C RH90%以下 RH90% or less				
オプション Option	防滴、ターミナルボックス、耐圧防爆 (d2G3) その他の電源 Drip-proof Type, Terminal Box, Explosion-proof Type Other above Power Source				

※ 通電時閉型につきまして、圧力0.1~3MPa仕様の製作は10~25Aまでとなります。32A以上は製作しておりません。

※ About normally open type, the fabrication of pressure range (0.1~3MPa) is for the size 10A to 25A. Not manufactured for over 32A.

■ 製品の型式記号 Model Type

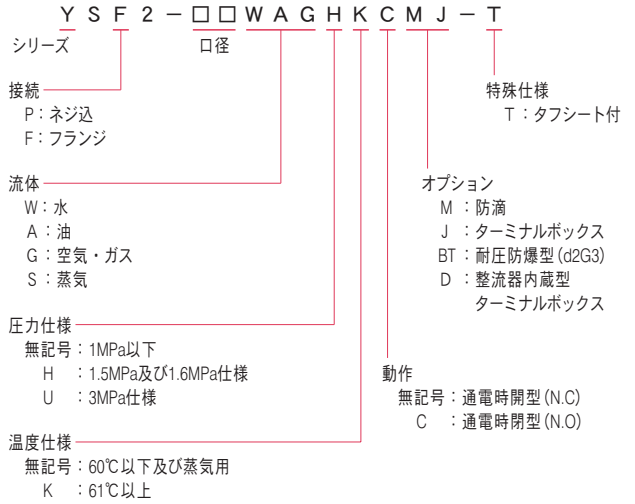

■ 仕様 Valve Specification

型式 Model	接続 Connection		オリフィス Orifice φ [mm]	コイル Coil No.		最低作動差圧 Min. Operating Pressure ΔP [MPa]	使用圧力範囲 Pressure Range [MPa]	皮相電力 [VA±10%] Apparent Power		Cv値 Cv Value	寸法 [mm] Dimensions			質量 Weight [kg]
	口径 Size	形状 Type		Water Oil	Air-Gas Steam			F Class	H Class		L	H ₁	H ₂	
YSP2-12	3/8	ネジ込 Rc	14.6	1.0		0.03	0.03~1	22	22	5.7	110	125	17	1.5
YSP2-15	1/2		110	125	17			1.5						
YSP2-20	3/4		20	1.5				9.0	125		135	20	2.0	
YSP2-25	1		25					14.0	140		150	26	3.0	
YSF2-12	3/8	フランジ JIS10KFF	15	1.0		0.03	0.03~1	22	22	5.7	125	125	45	2.5
YSF2-15	1/2		20	1.5				9.0	130		135	50	3.0	
YSF2-20	3/4		25					14.0	145		150	62.5	5.0	
YSF2-25	1		35	2.0				25.0	170		180	67.5	8.0	
YSF2-32	1 1/4		40					32.0	180		185	70	9.0	
YSF2-40	1 1/2		50					51.0	220		210	77.5	13.0	
YSF2-50	2		70	2.0				4.0	96.0		250	235	87.5	23.0
YSF2-65	2 1/2		80					131.0	280		250	92.5	28.0	
YSF2-80	3													
YSP2-12H	3/8		ネジ込 Rc	15	1.5			0.03	WAG: 0.03~2 S: 0.03~1.6		26	26	5.7	110
YSP2-15H	1/2	20				9.0	125			135	20	2.0		
YSP2-20H	3/4	25				14.0	140			150	26	3.0		
YSP2-25H	1													
YSF2-12H	3/8	フランジ JIS16KFF	14.6	1.5		0.03	WAG: 0.03~1.5 S: 0.03~1.6	26	26	5.7	125	125	45	2.5
YSF2-15H	1/2		20	4.0				9.0	130		135	50	3.0	
YSF2-20H	3/4		25					14.0	145		150	62.5	5.0	
YSF2-25H	1		35	1.5				25.0	170		180	67.5	8.0	
YSF2-32H	1 1/4		40					32.0	180		185	70	9.0	
YSF2-40H	1 1/2		50					51.0	220		210	77.5	13.0	
YSF2-50H	2		70					96.0	250		235	87.5	23.0	
YSF2-70H	2 1/2		80					131.0	284		250	100	28.0	
YSF2-80H	3													
YSP2-12U	3/8		ネジ込 Rc	15	2.0			0.1	0.1~3 ※		29	42	5.7	110
YSP2-15U	1/2	20				9.0	125			135	20	2.0		
YSP2-20U	3/4	25				14.0	140			150	26	3.0		
YSP2-25U	1													
YSF2-12U	3/8	フランジ JIS30KFF	14.6	2.0		0.1	0.1~3 ※	29	42	5.7	133	135	55	2.5
YSF2-15U	1/2		20	4.0				9.0	138		180	60	3.0	
YSF2-20U	3/4		25					14.0	157		195	65	5.0	
YSF2-25U	1		35	7.0				25.0	182		180	70	8.0	
YSF2-35U	1 1/4		40					32.0	192		185	80	9.0	
YSF2-40U	1 1/2		50					51.0	232		255	82.5	13.0	
YSF2-50UD	2		70					96.0	272		235	100	23.0	
YSF2-70U	2 1/2		80					131.0	306		250	105	28.0	
YSF2-80U	3													

※ Y-Uタイプ (圧力0.1~3MPa仕様) につきまして、蒸気用は製作しておりません。

※ Y-Uタイプ (圧力0.1~3MPa仕様) につきまして、空気用の製作は10~25Aまでとなります。32A以上は製作しておりません。

※ About Y-U type (pressure 0.1~3MPa):

・ Not manufactured for steam.

・ The fabrication for air is for the size 10A to 25A, not manufactured for over 32A.