

## Engineering Specification

Job Name \_\_\_\_\_

Contractor \_\_\_\_\_

Job Location \_\_\_\_\_

Approval \_\_\_\_\_

Engineer \_\_\_\_\_

Contractor's P.O. No. \_\_\_\_\_

Approval \_\_\_\_\_

Representative \_\_\_\_\_

# Cast Iron or Cast Bronze Flanged End Basket Type Strainers

Models: 125F-CI, Class 125

125F-B, Class 150

Sizes: 3/4" – 18" (10 – 450mm)

Strainers provide economical protection for costly pumps, meters, valves, and other similar mechanical equipment by straining foreign matter from the connected piping system. Installation of a strainer before mechanical equipment can ensure trouble free service and avoid costly shutdowns for repair or replacement of equipment damaged by foreign matter. The size of the perforation or mesh in the basket screen will determine the smallest particles captured. See Strainer Information section in the Mueller Steam Specialty Engineering binder for detailed information including sizes and materials available.

### Typical Service

- These strainers can be specified for cooling water, seawater, hot water systems and more.

### Features

- Designed for large capacity straining and ease of maintenance.
- Cover is secured with quick-opening knobs to minimize service time.
- O-ring seals on both the cover and baskets can usually be reused after service, no need to clean gasket residue and replace costly gaskets.
- Machined basket seat eliminates particle bypass.

### Construction

- Standard cover has O-ring seal and quick release knob fasteners up to 8" size, bolted cover for sizes 10" and up.
- Bolted cover available for all sizes, consult factory
- Swing clamp covers are available, consult factory
- Plugged NPT connection is provided at location D. See next page.



**Model 125F**

\* 125F supersedes Model 195.  
195 still available upon request.

### Pressure/Temperature–Non-Shock

Model	Material	Rating
125F-CI 3/4"-12"	Cast Iron	200psi @ -20°F to 150°F, 13.79 bar @ 65.56°C 190psi @ 200°F, 13.10 bar @ 93.33°C
125F-CI 14"-18"	Cast Iron	150psi @ -20°F to 150°F, 10.34 bar @ 65.56°C 125psi @ 250°F, 8.62 bar @ 121.11°C
125F-B 3/4"-18"	Al-Brz	225psi @ -20°F to 150°F, 15.51bar @ 65.56°C 210psi @ 200°F, 14.48 bar @ 93.33°C

All units with knob type closures rated 200psi maximum.

### Capacity

- Minimum 6 to 1 ratio

### Galvanizing

- Available on cast iron models. Other coatings are available on application.

### NOTICE

The information contained herein is not intended to replace the full product installation and safety information available or the experience of a trained product installer. You are required to thoroughly read all installation instructions and product safety information before beginning the installation of this product.

## Baskets

STANDARD (Water)				STEAM RECOMMENDATION	
MODEL	SIZES	MATERIAL	OPENING	MATERIAL	OPENING
125F-CI, 125F-B	3/4" - 4"	304SS	.062 perf	304SS	.062 perf
125F-CI, 125F-B	5" - 18"	304SS	.125 perf	304SS	.125 perf

## Materials

PART	CARBON STEEL	STAINLESS STEEL
1 Body	Carbon Steel ASTM A216 Gr. WCB	Stainless Steel ASTM A351 CF8M
2 Cover	Carbon Steel ASTM A216 Gr. WCB	Stainless Steel ASTM A351 CF8M
3 Basket	Stainless Steel 304	Stainless Steel 304
4 Basket Gasket	SS Tanged Graphite	SS Tanged Graphite
5 Cover Gasket	SS Tanged Graphite	SS Tanged Graphite
6 Studs	A193-B7	A193-B8M
7 Nuts	A-194-2H	A194-B8
8 Plug	Carbon Steel	Stainless Steel

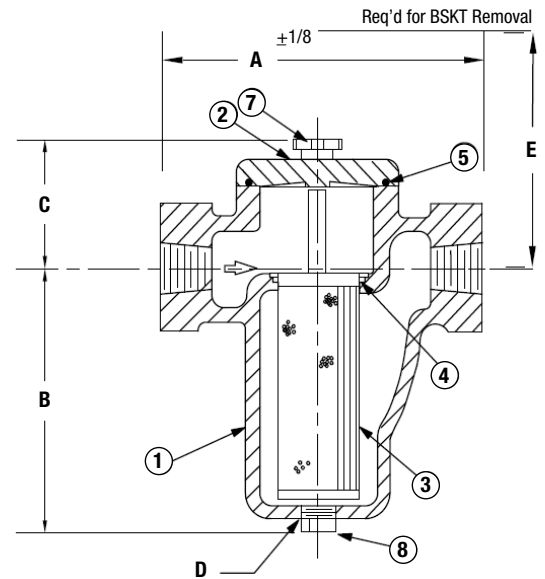

**Model 125F**

\*\*"B" dimension includes the floor supports on 4" size and larger.

## Pressure Drop

See Pressure Drop Charts in Technical Data section of Mueller Steam Engineering binder.

## Dimensions and Weights

SIZE		DIMENSIONS								WEIGHT					
		A		B		C		D(NPT)		E		Cast Iron		Bronze	
in.	mm	in.	mm	in.	mm	in.	mm	in.	mm	in.	mm	lbs.	kgs.	lbs.	kgs.
3/4	20	5 11/16	145	4 11/16	119	2 3/4	70	3/8	10	5 7/8	150	9	4	11	5
1	25	5 11/16	145	4 11/16	119	2 3/4	70	3/8	10	5 7/8	150	9	4	11	5
1 1/4	32	6 15/16	176	6 1/2	165	3	76	1/2	15	8 1/8	206	15	6.8	18	8
1 1/2	40	6 15/16	176	6 1/2	165	3	76	1/2	15	8 1/8	206	15	6.8	18	8
2	50	9	229	7 7/8	200	3 5/8	92	3/4	20	10 1/8	257	26	11	31	14
2 1/2	65	10 3/8	264	8 3/4	222	4	102	1	25	11 1/16	291	38	17	45	20
3	90	11 3/4	298	11 3/8	289	4 1/2	114	1	25	14 13/16	376	62	28	72	32
4	100	15	381	15 7/8	403	5 3/4	146	2	50	19 7/8	505	118	53.6	147	66
5	125	18 3/8	467	18 3/8	467	7 1/16	189	1 1/2	40	25 5/16	650	170	77	210	95
6	150	20 1/4	514	22 3/8	568	8 3/16	208	2	50	29 1/8	740	266	120	315	143
8	200	27 3/8	695	27 3/4	705	9 3/16	233	2	50	29 1/8	943	518	235	553	251
10	250	29 1/2	749	35 5/16	897	12 7/16	316	2	50	50 13/16	1291	1134	515	CF	CF
12	300	33 3/4	857	43 3/8	1114	10 3/4	273	2	50	61 1/4	1556	1200	544	CF	CF
14	350	47 3/8	1197	34 3/8	873	20 5/8	524	2	50	69	1753	1725	784	CF	CF
16	400	47 3/8	1197	34 3/8	873	20 1/16	510	2	50	69	1753	2100	954	CF	CF
18	450	49 1/2	1257	58	1381	16	406	2	50	82	2083	2850	1295	CF	CF

CF - Consult Factory. Apply for Certified Drawings.

**Limited Warranty:** Mueller Steam Specialty warrants each product to be free from defects in material and workmanship under normal usage for a period of one year from the date of original shipment. In the event of such defects within the warranty period, the Company will, at its option, replace or recondition the product without charge. This shall constitute the sole and exclusive remedy for breach of warranty, and the Company shall not be responsible for any incidental, special or consequential damages, including without limitation, lost profits or the cost of repairing or replacing other property which is damaged if this product does not work properly, other costs resulting from labor charges, delays, vandalism, negligence, fouling caused by foreign material, damage from adverse water conditions, chemical, or any other circumstances over which the Company has no control. This warranty shall be invalidated by any abuse, misuse, misapplication or improper installation of the product. **THIS WARRANTY IS IN LIEU OF ALL OTHER WARRANTIES, EXPRESS OR IMPLIED, INCLUDING ANY IMPLIED WARRANTIES OF MERCHANTABILITY OR FITNESS FOR A PARTICULAR PURPOSE.** Any implied warranties that are imposed by law are limited in duration to one year.

Some States do not allow limitations on how long an implied warranty lasts, and some States do not allow the exclusion or limitation of incidental or consequential damages. Therefore the above limitations may not apply to you. This Limited Warranty gives you specific legal rights, and you may have other rights that vary from State to State. You should consult applicable state laws to determine your rights.



**A WATTS Brand**

USA: T: (800) 334-6259 • F: (800) 421-6772 • MuellerSteam.com

Latin America: T: (52) 55-4122-0138 • MuellerSteam.com