



## CROSBY OMNI-TRIM® DIRECT SPRING PRESSURE RELIEF VALVES

Reliable and economical overpressure protection for thermal relief and many more applications



Series 900  
OMNI-TRIM®



Series BP  
OMNI-TRIM®

### FEATURES

- ASME/NB certified capacities for air, water and steam.
- Full compliance with all major global pressure relief standards including ASME VIII, API 527, EN4126, PED/CE and numerous other standards.
- Series 900 uses single trim design for liquid, gas, and vapor services.
- Highly customizable to meet most applications.
- Interchangeable parts to reduce maintenance costs.
- Full nozzle configuration.
- Simple and reliable design.
- Easy maintenance.
- Soft seat options for superior seat tightness.
- BP balanced piston option to offset the effects of variable back pressure.

### GENERAL APPLICATION

The Crosby OMNI-TRIM pressure relief valve is the proven solution for overpressure protection and/or thermal relief applications on air, gas, vapor, liquid and steam. Its simple design makes it ideal for refineries, chemical and petrochemical plants, power plant auxiliary systems and pulp and paper mills.

### TECHNICAL DATA

Sizes:	1/2" x 1" to 2" x 2" and 1 1/2" x 2 1/2" (DN 15 x 25 to 50 x 50 and 40 x 65)
Orifices:	0.074 to 0.503 in <sup>2</sup> (47.7 to 325 mm <sup>2</sup> )
Connections:	NPT, flanged, male socket weld
Temperature range:	-450 to +750°F (-268 to +399°C)
Set pressures:	5 to 5000 psig (0.34 to 345 barg)
Steam limit:	1000 psig (69 barg)
Codes:	ASME VIII and III

# CROSBY OMNI-TRIM®

## DIRECT SPRING PRESSURE RELIEF VALVES

---

### CONTENTS

---

Product range information.....	3-8
Caps and lifting levers.....	9
Series 900 valve configurations.....	10

### Dimensions/weights/pressure and temperature ratings

Series 900.....	15-22
Series BP.....	23-24

### Capacities

Series 900.....	25-35
Series BP.....	36-39
Series BP back pressure flow correction factors.....	40

### Ordering information

Series 900/BP.....	41-42
Parts.....	43
Sizing and selection software.....	44

### MODELS OVERVIEW

---

#### Series 900 OMNI-TRIM

Series 900 OMNI-TRIM pressure relief valves provide overpressure protection on air, gas, vapor, liquid thermal relief and steam service. Maximum fixed blowdown is typically 20% or less. Standardization of components in the OMNI-TRIM provides easy assembly, durability, ease of maintenance and lower inventory costs. The design and wide array of options provide maximum versatility and premium performance.

Sizes:	½" x 1" to 2" x 2" and 1½" x 2½"
Orifices:	0.074 to 0.503 in <sup>2</sup> (47.74 to 324.5 mm <sup>2</sup> )
Connections:	NPT, flanged, male socket weld
Temperature range:	-450 to +750°F (-268 to +399°C)
Set pressures:	5 to 5000 psig (0.34 to 344.83 barg)
Steam limit:	1000 psig
Code:	ASME VIII and ASME III (15 psig and above)

#### Series BP OMNI-TRIM®

Series BP OMNI-TRIM® pressure relief valve is a piston, single trim designed valve for gas, vapor and liquid applications involving variable back pressure. Full nozzle design with O-ring seat as standard.

Sizes:	¾" x 1" and 1" x 1"
Orifices:	0.074 and 0.110 in <sup>2</sup> (47.74 and 71 mm <sup>2</sup> )
Connections:	NPT, flanged
Temperature range:	-20 to +400°F (-28 to +204°C)
Set pressures:	50 to 1500 psig (3.45 to 103.44 barg)
Code:	ASME VIII and ASME III

# CROSBY OMNI-TRIM®

## SERIES 900 FIXED BLOWDOWN OMNI-TRIM PRESSURE RELIEF VALVE

### PRODUCT OVERVIEW

Series 900 OMNI-TRIM pressure relief valves provide overpressure protection on air, gas, vapor, liquid thermal relief and steam service. Maximum fixed blowdown is typically 20% or less. Standardization of components in the OMNI-TRIM provides easy assembly, durability, ease of maintenance and lower inventory costs. The design and wide array of options provide maximum versatility and premium performance.

### ASME code requirements

The valves are manufactured to ASME Boiler and Pressure Vessel Code, Section VIII for pressures of 15 psig (1.03 barg) and above and can also be manufactured to Section III for nuclear-related applications.

### Other type approvals and certifications

- Canadian Registration Number (CRN)
- China Manufacturing License (TS)
- Pressure Equipment Directive (97/27/EC), (ISO-4126-1) (OE)
- United States Coast Guard (USCG)

### Connections

The Series 900 OMNI-TRIM is supplied with screwed inlet and outlet connections as standard but is also available with optional flanged end connections or male socket weld ends. Standard flanged end connections are Lap Joint Inlet and Lap Joint Outlet for the 972, 981 & 991 models. However, the standard flanged end connections are Lap Joint Inlet and Integral Cast Outlet for the 951, 955, 961 & 965 models. Optional flanged end connections with unique face-to-face dimensions to match existing installations are also available. Contact your sales representative for availability of these and other special designs.

For installations where a bolted cylinder is preferred for maintenance reasons, a special version of the No. 5 orifice is available in ¾" x 1 connection size only. This valve is designated as 95110199A and has a maximum set pressure of 1500 psig (103 barg). Standard connections are ¾" x 1 MNPT x FNPT. For optional flanged construction, please contact your sales representative.

### Seat design

The valve is available with flat metal-to-metal, elastomer or TFE O-ring soft seats for optimum seat tightness and minimal maintenance. O-rings are standard commercial sizes.

### O-RING SOFT SEAT MATERIALS<sup>(1)</sup> AND PRESSURE/TEMPERATURE LIMITS

Material	Set pressure psig (barg)		Inlet temperature °F (°C)	
	Minimum	Maximum	Minimum	Maximum
Buna-N	15 (1.03)	2500 (172.41)	-50 (-45.6)	+250 (+121.1)
Viton® <sup>(3)</sup> (FKM)	15 (1.03)	2500 (172.41)	0 (-17.8)	+400 (+204.4)
EPR <sup>(2)</sup>	15 (1.03)	2500 (172.41)	-50 (-45.6)	+250 (+121.1)
Kalrez® <sup>(2)</sup>	15 (1.03)	2500 (172.41)	0 (-17.8)	+500 (+260.0)
TFE <sup>(2)</sup>	100 (6.89)	2500 (172.41)	-50 (-45.6)	+500 (+260.0)
Silicone	15 (1.03)	1500 (103.44)	-50 (-45.6)	+400 (+204.4)

### NOTES

1. Metal-to-metal seats are recommended for steam service. Contact your sales representative if soft seats are required.
2. EPR = ethylene propylene rubber, TFE = tetrafluorethylene. Kalrez® is a registered trademark of DuPont Dow Elastomers.
3. Viton® is a registered trademark of DuPont Performance Elastomers L.L.C.

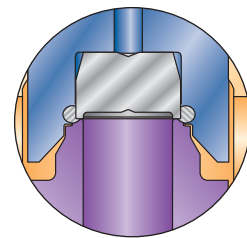
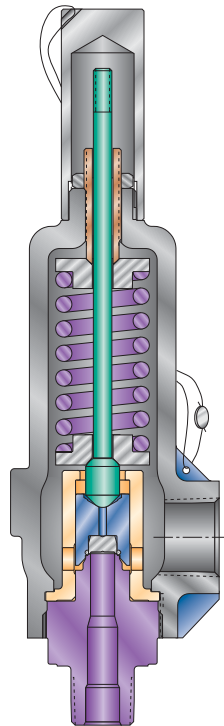

O-ring soft seat

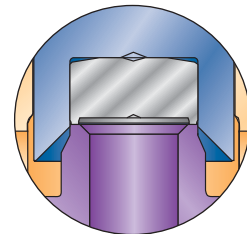

Metal-to-metal seat

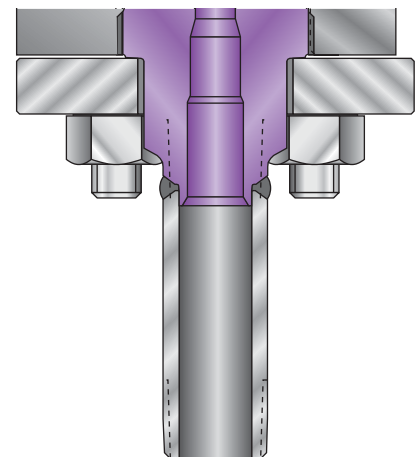

Series 900 bolted cylinder

# CROSBY OMNI-TRIM®

## SERIES 900 FIXED BLOWDOWN OMNI-TRIM PRESSURE RELIEF VALVE

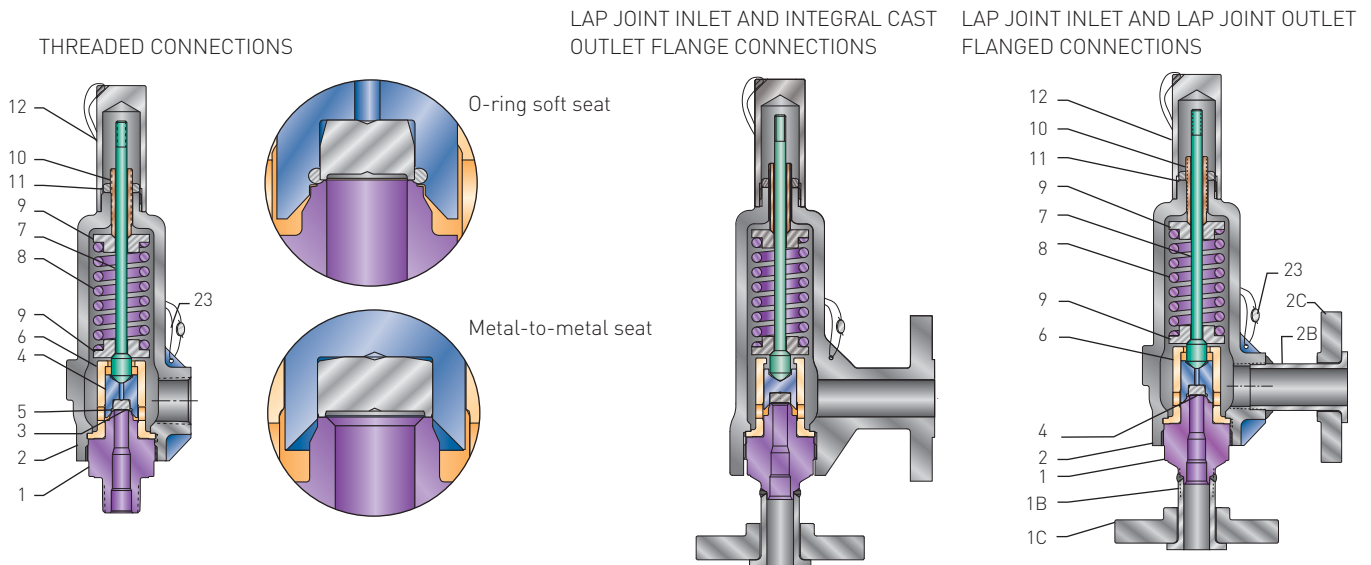

### MATERIALS OF CONSTRUCTION

Part no.	Part name	Standard materials	Variations from standard materials						
		0 <sup>(13)</sup>	Material designation						
			1	2 <sup>(10)</sup>	3 <sup>(13)</sup>	4 <sup>(10)</sup>	5 <sup>(13)</sup>	6	7 <sup>(10, 13)</sup>
		-50°F to +750°F [-45.6°C to +399°C]	-450°F to +500°F [-268°C to +260°C]	-450°F to +750°F [-268°C to +399°C]	-50°F to +750°F [-45.6°C to +399°C]	-320°F to +750°F [-196°C to +399°C]	-50°F to +750°F [-45.6°C to +399°C]	-320°F to +750°F [-196°C to +399°C]	-50°F to +750°F [-45.6°C to +399°C]
									ANSI/NACE MR0175/ ISO 15156-1:2015
1	Base	316 SS	316 SS	316 SS	Monel®	Monel®	Hastelloy® C	Hastelloy® C	316 SS
2	Cylinder <sup>(11,12)</sup>	Carbon steel SA-216 Gr. WCB	<b>316 SS</b> <b>SA-351</b> <b>Gr. CF8M</b>	<b>316 SS</b> <b>SA-351</b> <b>Gr. CF8M</b>	Carbon steel SA-216 Gr. WCB	Monel <sup>(7)</sup> <b>ASTM A 494</b> <b>Gr. M35-1</b>	Carbon steel SA-216 Gr. WCB	<b>Hastelloy® C</b> <b>SA-494</b> <b>Gr. CW-12MW</b>	Carbon steel SA-216 Gr. WCB
3	Disc insert <sup>(3)</sup>	316 SS	316 SS	316 SS	Monel®	Monel®	Hastelloy® C	Hastelloy® C	316 SS
4	Disc holder	316 SS <sup>(1)</sup>	316 SS <sup>(1)</sup>	316 SS <sup>(1)</sup>	Monel®	Monel®	Hastelloy® C	Hastelloy® C	316 SS <sup>(1)</sup>
5	O-ring <sup>(2,3)</sup>	Specify	Specify	Specify	Specify	Specify	Specify	Specify	Specify
6	Guide	316 SS	316 SS	316 SS	Monel®	Monel®	Hastelloy® C	Hastelloy® C	316 SS
7	Spindle <sup>(8)</sup>	416 SS	<b>316 SS</b>	<b>316 SS</b>	416 SS	Monel®	416 SS	Hastelloy® C	<b>316 SS</b>
8	Spring	17-7PH SS	<b>316 SS</b>	<b>Inconel® X750</b>	<b>Inconel® X750</b>	<b>Inconel® X750</b>	<b>Inconel® X750</b>	Hastelloy® C	<b>Inconel® X750</b>
9	Spring washers	416 SS	<b>316 SS</b>	<b>316 SS</b>	<b>316 SS</b>	Monel®	<b>316 SS</b>	Hastelloy® C	<b>316 SS</b>
10	Adjusting bolt	416 SS	<b>316 SS</b>	<b>316 SS</b>	416 SS	Monel®	416 SS	Hastelloy® C	<b>316 SS</b>
11	Adj. bolt nut	Carbon steel	<b>316 SS</b>	<b>316 SS</b>	Carbon steel	Monel®	Carbon steel	Hastelloy® C	<b>316 SS</b>
12	Type A cap <sup>(4)</sup>	Carbon steel	<b>316 SS</b>	<b>316 SS</b>	Carbon steel	Monel®	Carbon steel	Hastelloy® C	Carbon steel
13	Nameplate <sup>(5)</sup>	300 Series SS	300 Series SS	300 Series SS	300 Series SS	300 Series SS	300 Series SS	300 Series SS	300 Series SS
14	Drive screws <sup>(5)</sup>	SS	SS	SS	SS	SS	SS	SS	SS
15	Seal and wire	Lead and SS	Lead and SS	Lead and SS	Lead and SS	Lead and SS	Lead and SS	Lead and SS	Lead and SS
1B	Lap joint stub end (inlet)	316 SS	316 SS	316 SS	Monel®	Monel®	Hastelloy® C	Hastelloy® C	316 SS
1C	Inlet flange	Carbon steel <sup>(6)</sup>	<b>316 SS</b>	<b>316 SS</b>	Carbon steel <sup>(6)</sup>	Carbon steel <sup>(6)</sup>	Carbon steel <sup>(6)</sup>	Carbon steel <sup>(6)</sup>	Carbon steel <sup>(6)</sup>
2B	Lap joint stub end (outlet)	Carbon steel <sup>(6)</sup>	<b>316 SS</b>	<b>316 SS</b>	Carbon steel <sup>(6)</sup>	Monel®	Carbon steel <sup>(6)</sup>	Hastelloy® C	Carbon steel <sup>(6)</sup>
2C	Outlet flange	Carbon steel <sup>(6)</sup>	<b>316 SS</b>	<b>316 SS</b>	Carbon steel <sup>(6)</sup>	Carbon steel <sup>(6)</sup>	Carbon steel <sup>(6)</sup>	Carbon steel <sup>(6)</sup>	Carbon steel <sup>(6)</sup>

Materials in bold indicate variation from standard.

### NOTES

- Material is 17-4PH SS for steam applications.
- Refer to page 5 for pressure/temperature limits and available O-ring materials. Used on soft seated valve only.
- Recommended spare part.
- Refer to page 9 for other available cap styles and materials.
- Not shown.
- Low temperature limit for carbon steel flanges is -20°F (-28.9°C). Use 316 SS below -20°F.
- ASME Code Case 1750-17.
- Styles 9511 ( )-STM and 9611 ( )-STM spindle furnished as spindle and spindle ball sub-assembly.
- A nickel/graphite based lubricant/sealant is used on threads, sealing and bearing surfaces.
- Available with ANSI/NACE MR0175/ISO 15156-1:2015 (N2) model number supplement.
- The standard flanged end connections are Lap Joint Inlet and Integral Cast Outlet for the 951, 955, 961, 965 & 972 models in WCB & 316 SS materials only.
- Standard flanged end connections are Lap Joint Inlet and Lap Joint Outlet for the 981 & 991 models.
- Please consult factory for applications with temperature below -20°F (-28.9°C).

# CROSBY OMNI-TRIM®

## SERIES BP BALANCED OMNI-TRIM PRESSURE RELIEF VALVE

### PRODUCT OVERVIEW

Series BP OMNI-TRIM® pressure relief valve is a piston, single trim designed valve for gas, vapor and liquid applications involving variable back pressure. Full nozzle design with O-ring seat as standard.

#### Back pressure

The maximum allowable back pressure in liquid applications is 70% of set pressure; in vapor and gas applications it is 50% and for liquid thermal relief applications 90% of set pressure. Note: The maximum back pressure rating is 400 psig (27.58 barg). For back pressures greater than 400 psig (27.58 barg), consult Crosby.

#### Blowdown

Series BP blowdown is fixed and non-adjustable (typically 25% or less) on liquid, gas and vapor applications.

#### Optional connections

The valves may be furnished with optional flanged connections up to ANSI Class 1500. Standard flanged connections are lap joint stub end construction.

#### Materials

Optional materials of construction are available for special applications or conditions involving corrosive fluids. All materials used in the primary (wetted while the valve is closed) pressure zone of the pressure relief valve meet the material requirements of the current revision of ANSI/NACE MR0175/ISO 15156-1:2015. Contact your sales representative for specific compliance to NACE requirements. Special cleanings, coatings and lubricants are also available on application.

The purchaser must decide whether their specific application requires compliance to NACE recommendations. Emerson will provide materials that meet the material requirements in the requested NACE specification; however, the purchaser must ensure all valve materials selected meet their application's NACE requirements.

Special cleanings, coatings and lubricants are also available on application.

#### ASME code requirements

Series BP pressure relief valves are manufactured to ASME Boiler and Pressure Vessel Code, Sections VIII and III.

#### Other type approvals and certifications

- Canadian Registration Number (CRN)
- China Manufacturing License (TS)
- Pressure Equipment Directive (97/27/EC), (ISO-4126-1) (OE)

### O-RING SOFT SEAT MATERIALS AND PRESSURE/TEMPERATURE LIMITS

Material	Set pressure psig (barg)		Inlet temperature °F (°C)	
	Minimum	Maximum	Minimum	Maximum
Buna-N	50 (3.45)	1500 (103.44)	-20 (-28)	+250 (+121.1)
Viton®*(FKM)	50 (3.45)	1500 (103.44)	0 (-17.8)	+400 (+204.4)
EPR*	50 (3.45)	1500 (103.44)	-20 (-28)	+250 (+121.1)
Kalrez®*	100 (6.89)	1500 (103.44)	0 (-17.8)	+400 (+204.4)
TFE*	100 (6.89)	1500 (103.44)	-20 (-28)	+400 (+204.4)
Silicone	50 (3.45)	1500 (103.44)	-20 (-28)	+400 (+204.4)

#### NOTE

\* EPR = ethylene propylene rubber, TFE = tetrafluoroethylene. Kalrez® is a registered trademark of DuPont Dow Elastomers. Viton® is a registered trademark of DuPont Performance Elastomers L.L.C.

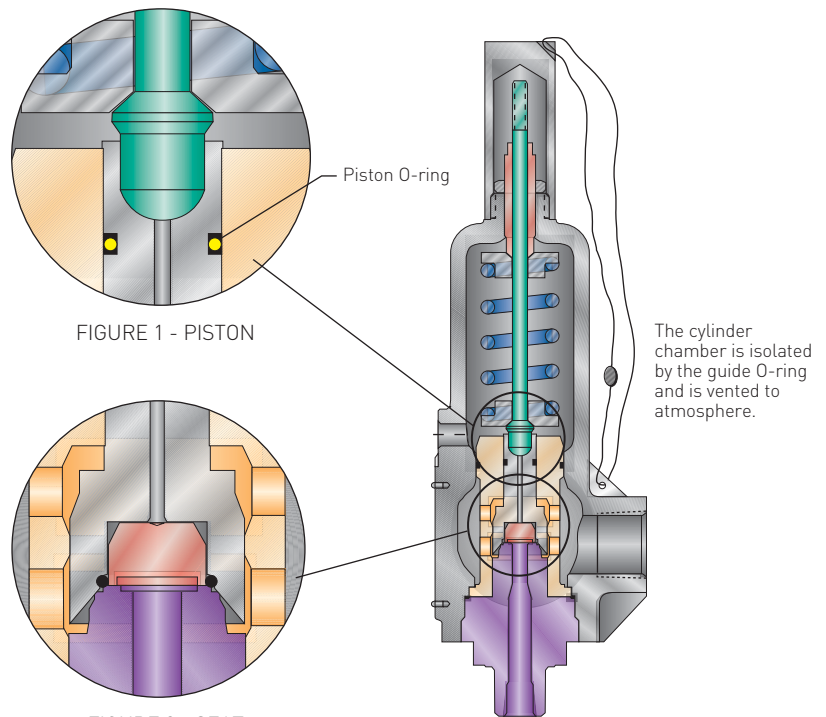

FIGURE 1 - PISTON

FIGURE 2 - SEAT

#### Seat design

Valves are available with elastomer or TFE O-ring soft seats for optimum seat tightness and minimal maintenance. All O-rings are standard commercial sizes.

# CROSBY OMNI-TRIM®

## SERIES BP OMNI-TRIM PRESSURE RELIEF VALVE

### THREADED CONNECTIONS

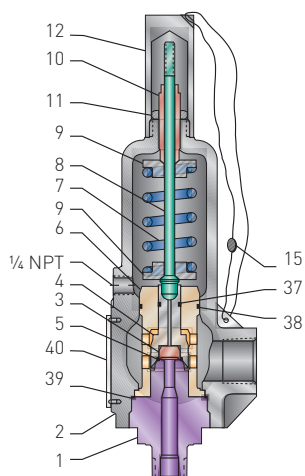

### FLANGED CONNECTIONS

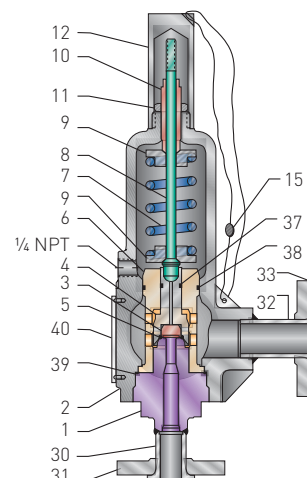

### MATERIALS OF CONSTRUCTION

Part no.	Part name	Standard materials	Variations from standard materials						
		0	1	3	Material designation				7 <sup>(6)</sup> ANSI/NACE <sup>(5)</sup> MR0175/ ISO 15156-1:2015
					4 <sup>(6)</sup>	5	6	7 <sup>(6)</sup>	
		-20°F to +400°F (-28°C to +204°C)	-20°F to +400°F (-28°C to +204°C)	-20°F to +400°F (-28°C to +204°C)	-20°F to +400°F (-28°C to +204°C)	-20°F to +400°F (-28°C to +204°C)	-20°F to +400°F (-28°C to +204°C)	-20°F to +400°F (-28°C to +204°C)	
1	Base	316 SS	316 SS	Monel®	Monel®	Hastelloy® C	Hastelloy® C	316 SS	
2	Cylinder	Carbon steel SA-216 Gr. WCB	<b>316 SS</b> <b>SA-351</b> <b>Gr. CF8M</b>	Carbon steel SA-216 Gr. WCB	Monel® <b>ASTM A 494</b> <b>Gr. M35-1</b>	Carbon steel SA-216 Gr. WCB	Hastelloy® C <b>SA-494</b> <b>Gr. CW-12MW</b>	Carbon steel SA-216 Gr. WCB	
3	Disc insert <sup>(1)</sup>	316 SS	316 SS	Monel®	Monel®	Hastelloy® C	Hastelloy® C	316 SS	
4	Disc holder	316 SS	316 SS	Monel®	Monel®	Hastelloy® C	Hastelloy® C	316 SS	
5	Seat O-ring <sup>(1,2)</sup>	Specify	Specify	Specify	Specify	Specify	Specify	Specify	
6	Guide	316 SS	316 SS	Monel®	Monel®	Hastelloy® C	Hastelloy® C	316 SS	
7	Spindle	416 SS	<b>316 SS</b>	416 SS	Monel®	416 SS	Hastelloy® C	<b>316 SS</b>	
8	Spring	17-7PH SS	<b>316 SS</b>	Inconel® X750	Inconel® X750	Inconel® X750	Hastelloy® C	Inconel® X750	
9	Spring washers	416 SS	<b>316 SS</b>	<b>316 SS</b>	Monel®	<b>316 SS</b>	Hastelloy® C	<b>316 SS</b>	
10	Adjusting bolt	416 SS	<b>316 SS</b>	416 SS	Monel®	416 SS	Hastelloy® C	<b>316 SS</b>	
11	Adj. bolt nut	Carbon steel	<b>316 SS</b>	Carbon steel	Monel®	Carbon steel	Hastelloy® C	<b>316 SS</b>	
12	Type A cap <sup>(3)</sup>	Carbon steel	<b>316 SS</b>	Carbon steel	Monel®	Carbon steel	Hastelloy® C	Carbon steel	
13	Nameplate <sup>(4)</sup>	300 Series SS	300 Series SS	300 Series SS	300 Series SS	300 Series SS	300 Series SS	300 Series SS	
14	Drive screws <sup>(4)</sup>	SS	SS	SS	SS	SS	SS	SS	
15	Seal and wire	Lead and SS	Lead and SS	Lead and SS	Lead and SS	Lead and SS	Lead and SS	Lead and SS	
30	Lap joint stub end (inlet)	316 SS	316 SS	Monel®	Monel®	Hastelloy® C	Hastelloy® C	316 SS	
31	Inlet flange	Carbon steel	<b>316 SS</b>	Carbon steel	Carbon steel	Carbon steel	Carbon steel	Carbon steel	
32	Lap joint stub end (outlet)	Carbon steel	<b>316 SS</b>	Carbon steel	Monel®	Carbon steel	Hastelloy® C	Carbon steel	
33	Outlet flange	Carbon steel	<b>316 SS</b>	Carbon steel	Carbon steel	Carbon steel	Carbon steel	Carbon steel	
37	O-ring piston <sup>(1)</sup>	Specify	Specify	Specify	Specify	Specify	Specify	Specify	
38	O-ring guide <sup>(1)</sup>	Specify	Specify	Specify	Specify	Specify	Specify	Specify	
39	O-ring cylinder <sup>(1)</sup>	Specify	Specify	Specify	Specify	Specify	Specify	Specify	
40	Caution plate	300 Series SS	300 Series SS	300 Series SS	300 Series SS	300 Series SS	300 Series SS	300 Series SS	

Materials in bold indicate variation from standard.

### NOTES

1. Recommended spare part.
2. Refer to page 7 for pressure/temperature limits and available O-ring materials.
3. Refer to page 9 for other available cap styles and materials.
4. Not shown.
5. Contact your sales representative for specific compliance to NACE requirements.
6. Available with ANSI/NACE MR0175/ISO 15156-1:2015 (N2) model number supplement.

# CROSBY OMNI-TRIM®

## CAPS AND LIFTING LEVERS

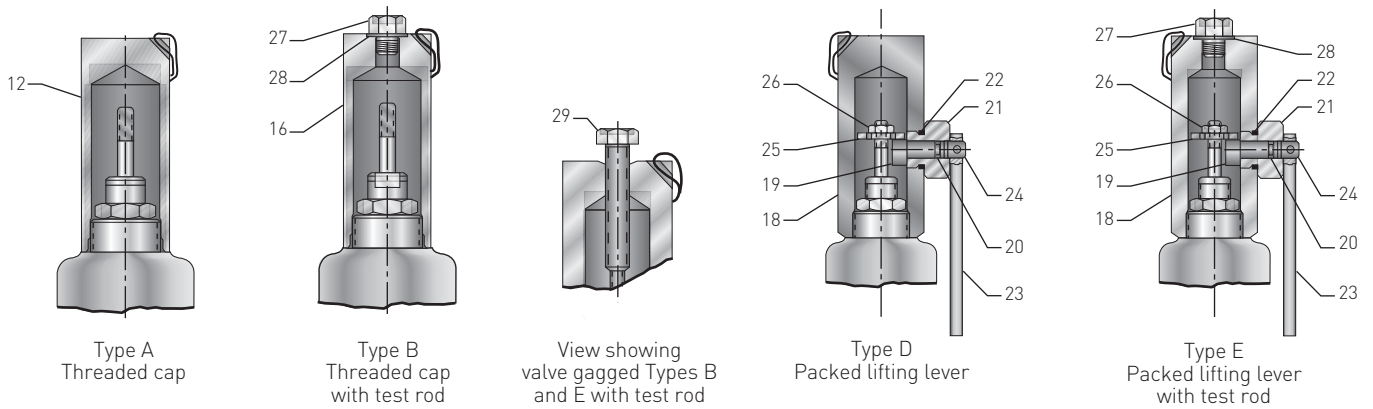

### MATERIALS OF CONSTRUCTION

Cap type	Part no.	Part name	Material designation			
			0, 3, 5	1, 2	4	6
<b>A</b>	12	Cap	Steel	<b>316 SS</b>	<b>Monel®</b>	<b>Hastelloy® C</b>
<b>B</b>	16	Cap	Steel	<b>316 SS</b>	<b>Monel®</b>	<b>Hastelloy® C</b>
	27	Cap plug	Steel	<b>316 SS</b>	<b>Monel®</b>	<b>Hastelloy® C</b>
	28	Cap plug O-ring	FKM	FKM	FKM	FKM
	29	Test rod	Steel (plated)	Steel (plated)	Steel (plated)	Steel (plated)
<b>D</b>	18	Cap	Steel	<b>316 SS</b>	<b>Monel®</b>	<b>Hastelloy® C</b>
	19	Cam	416 SS	<b>316 SS</b>	<b>Monel®</b>	<b>Hastelloy® C</b>
	20	Cam O-ring	FKM	FKM	FKM	FKM
	21	Cam sleeve	416 SS	<b>316 SS</b>	<b>Monel®</b>	<b>Hastelloy® C</b>
	22	Cam sleeve O-ring	FKM	FKM	FKM	FKM
	23	Lever	Steel	Steel	Steel	Steel
	24	Lever pin	302 SS	302 SS	302 SS	302 SS
	25	Spindle nut	Steel	<b>316 SS</b>	<b>Monel®</b>	<b>Hastelloy® C</b>
	26	Locknut	Steel (plated)	<b>300 Series SS</b>	<b>Monel®</b>	<b>Hastelloy® C</b>
	<b>E</b>	18	Cap	Steel	<b>316 SS</b>	<b>Monel®</b>
19		Cam	416 SS	<b>316 SS</b>	<b>Monel®</b>	<b>Hastelloy® C</b>
20		Cam O-ring	FKM	FKM	FKM	FKM
21		Cam sleeve	416 SS	<b>316 SS</b>	<b>Monel®</b>	<b>Hastelloy® C</b>
22		Cam sleeve O-ring	FKM	FKM	FKM	FKM
23		Lever	Steel	Steel	Steel	Steel
24		Lever pin	302 SS	302 SS	302 SS	302 SS
25		Spindle nut	Steel	<b>316 SS</b>	<b>Monel®</b>	<b>Hastelloy® C</b>
26		Locknut	Steel (plated)	<b>300 Series SS</b>	<b>Monel®</b>	<b>Hastelloy® C</b>
27		Cap plug	Steel	<b>316 SS</b>	<b>Monel®</b>	<b>Hastelloy® C</b>
28		Cap plug O-ring	FKM	FKM	FKM	FKM
29	Test rod	Steel (plated)	Steel (plated)	Steel (plated)	Steel (plated)	

Materials in bold indicate variation from standard.

Crosby Series 900 OMNI-TRIM® and Series BP pressure relief valves are furnished with a threaded cap over the adjusting bolt as a standard. Optional cap types and lifting levers are:

- Standard threaded cap (Type A)  
Where no lifting lever is required.
- Threaded cap with test rod (Type B)  
Normally used to hold the pressure relief valve closed when the system is being tested hydrostatically.
- Packed lifting lever (Type D)  
For applications where periodic testing is desirable. This is a sealed design for pressure integrity.

- Packed lifting lever with test rod (Type E).  
Same as Type D except furnished with a test rod.

#### NOTE

ASME Boiler and Pressure Vessel Code rules require that a lifting lever must be supplied with the valve when the service is (1) air, (2) water at the valve inlet that exceeds 140°F (60°C) excluding over pressure or relief events or (3) steam.

#### CAUTION

Test rods should never be tightened more than finger tight. Overtightening may damage internal parts. Moreover, a test rod should never be kept on the valve during operation of the equipment.

During normal operation the test rod is replaced with cap plug and O-ring to maintain tightness on the discharge side.

**CROSBY OMNI-TRIM®**  
**SERIES 900 VALVE CONFIGURATIONS**

SERIES 900

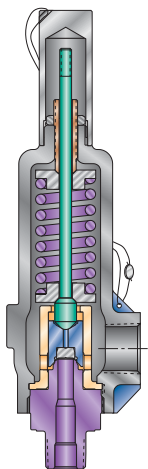

Standard threaded  
 MNPT x FNPT<sup>[3]</sup>

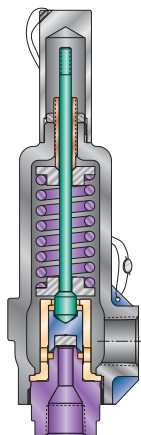

Threaded  
 FNPT x FNPT<sup>[3]</sup>

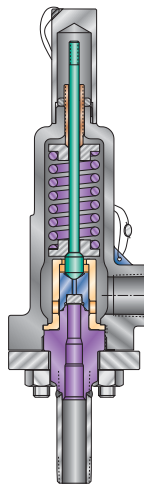

Bolted cylinder  
 MNPT x FNPT<sup>[3]</sup>  
 Available in no. 5 orifice only

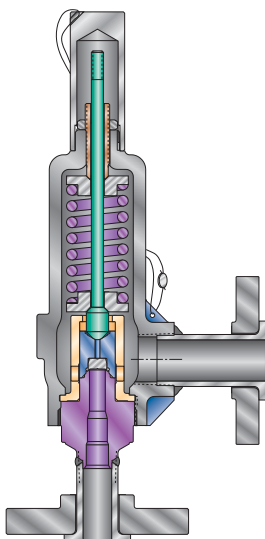

Lap joint inlet flange x  
 Lap joint outlet flange<sup>[4]</sup>

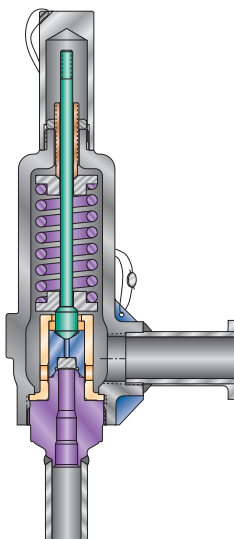

Male SW x Male SW<sup>[5,6]</sup>  
 (socket weld)

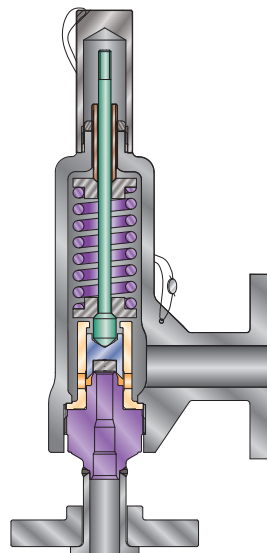

Lap joint x Integral-A cast  
 outlet flange connections<sup>[4]</sup>

**NOTES**

1. Dimensions, weights and pressure/temperature ratings are found on pages 11 and 13.
2. Dimensions, weights and pressure/temperature ratings are found on pages 12 and 14.
3. Dimensions, weights and pressure/temperature ratings are found on pages 15-16 and 19-20.
4. Dimensions, weights and pressure/temperature ratings are found on pages 17-18 and 21-22.
5. Contact your sales representative for dimensions and weights.
6. Valves with SW connections not available with O-ring seats.



# CROSBY OMNI-TRIM®

## SPECIFICATIONS

SERIES 900 OMNI-TRIM® THREADED CONNECTIONS (NPT) - USCS (U.S. CUSTOMARY SYSTEM) UNITS

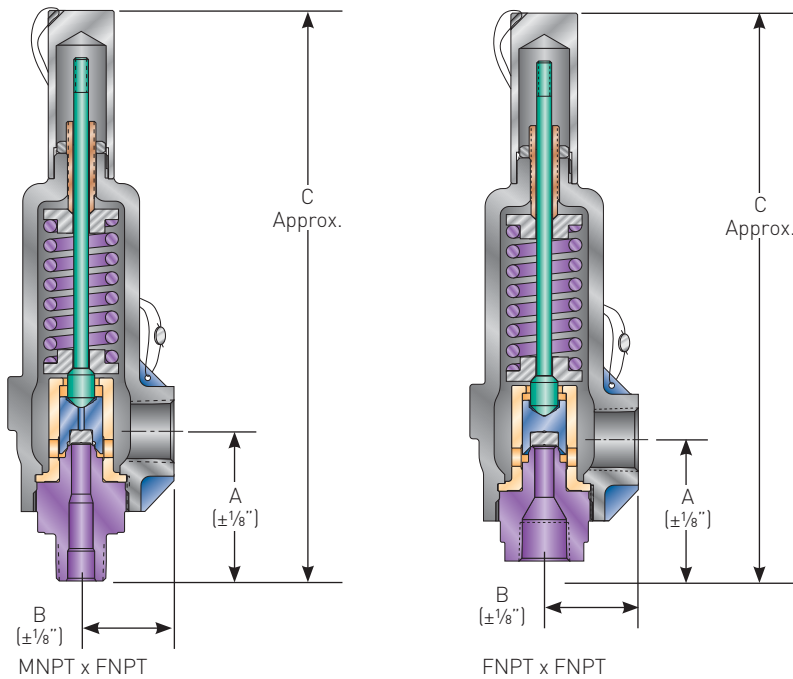

**SERIES 900 DIMENSIONS AND WEIGHTS, PRESSURE/TEMPERATURE RATINGS (continued next page)**

Valve style number	Connection size (NPS)		Minimum <sup>(4)</sup> set pressure (psig)	Maximum <sup>(1,3)</sup> set pressure (psig)	Maximum outlet pressure (psig)	Temperature <sup>(1)</sup> range (°F)	Dimensions (in.)			Approx. weight (lbs)
	Inlet	Outlet					A	B	C <sup>(2)</sup>	
<b>Style 951 - Series 900 with no. 5 orifice (0.074 sq. in.)* and 1500 psig maximum set pressure</b>										
9511( )0MF	1/2	1	5	1500	400	-450/+750	3	1 3/4	10 3/8	7
9511( )1MF	3/4	1	5	1500	400	-450/+750	3	1 3/4	10 3/8	7
9511( )2MF	1	1	5	1500	400	-450/+750	3 1/4	1 3/4	10 3/8	7
<b>Style 951 - Series 900 bolted connection with no. 5 orifice (0.074 sq. in.) and 1500 psig max. set pressure<sup>(5)</sup></b>										
9511( )199	3/4	1	5	1500	400	-450/+750	6 13/16	1 3/4	14 1/4	12
<b>Style 955 - Series 900 with no. 5 orifice (0.074 sq. in.)* and 5000 psig maximum set pressure</b>										
9551( )0MF	1/2	1	1501	5000	400	-450/+750	3 1/8	1 15/16	11 7/8	9
9551( )1MF	3/4	1	1501	5000	400	-450/+750	3 1/8	1 15/16	11 7/8	9
9551( )2MF	1	1	1501	5000	400	-450/+750	3 3/8	1 15/16	12 1/8	9
<b>Style 961 - Series 900 with no. 6 orifice (0.110 sq. in.) and 1500 psig maximum set pressure</b>										
9611( )0MF	1/2	1	5	1500	400	-450/+750	3 1/8	1 15/16	11 7/8	10
9611( )1MF	3/4	1	5	1500	400	-450/+750	3 1/8	1 15/16	11 7/8	10
9611( )2MF	1	1	5	1500	400	-450/+750	3 3/8	1 15/16	12 1/8	10
9611( )1FF	3/4	1	5	1500	400	-450/+750	2 1/2	1 15/16	11 1/4	10
9611( )2FF	1	1	5	1500	400	-450/+750	2 7/8	1 15/16	11 5/8	10

\* Consult your sales representative for availability of no. 5 (0.074 sq. in.) orifice with FNPT inlet.

**NOTES**

1. Minimum/maximum set pressures and temperatures shown apply to metal seated valves only. Refer to page 5 for pressure and temperature limits for soft seat construction.
2. Dimension 'C' shown is for Type A cap.  
For Type B cap, add 1/4 in. to 'C' dimension (an additional 2 in. is required for test rod head clearance).  
For Type D cap, add 5/8 in. to 'C' dimension.  
For Type E cap, add 7/8 in. to 'C' dimension (an additional 2 in. is required for test rod head clearance).
3. Maximum set pressure for steam service is 1000 psig.
4. Valves set below 15 psig cannot be stamped with the ASME Code Symbol. Only metal seated valves may be set below 15 psig. For set pressure applications below the published minimum values, consult your sales representative.
5. See page 5.

# CROSBY OMNI-TRIM®

## SPECIFICATIONS

### SERIES 900 DIMENSIONS AND WEIGHTS, PRESSURE/TEMPERATURE RATINGS (continued)

Valve style number	Connection size (NPS)		Minimum <sup>(4)</sup>	Maximum <sup>(1,3)</sup>	Maximum outlet	Temperature <sup>(1)</sup>	Dimensions (in.)			Approx. weight (lbs)
	Inlet	Outlet	set pressure (psig)	set pressure (psig)	pressure (psig)	range (°F)	A	B	C <sup>(2)</sup>	
<b>Style 965 - Series 900 with no. 6 orifice (0.110 sq. in.) and 5000 psig maximum set pressure</b>										
9651( )1MF	¾	1	1501	5000	400	-450/+750	3½	2½	13½	16
9651( )2MF	1	1	1501	5000	400	-450/+750	3¾	2½	13¾	16
9651( )3MF	1	1½	1501	5000	400	-450/+750	3¾	2½	13¾	16
9651( )1FF	¾	1	1501	5000	400	-450/+750	2½	2½	12½	16
9651( )2FF	1	1	1501	5000	400	-450/+750	3½	2½	12¾	16
9651( )3FF	1	1½	1501	5000	400	-450/+750	3½	2½	12¾	16
<b>Style 972 - Series 900 with no. 7 orifice (0.196 sq. in.) and 2500 psig maximum set pressure</b>										
9721( )3MF	1	1½	6	2500	400	-450/+750	3¾	2½	13¾	17
9721( )4MF	1½	1½	6	2500	400	-450/+750	3¾	2½	13¾	17
9721( )3FF	1	1½	6	2500	400	-450/+750	3½	2½	12¾	17
9721( )4FF	1½	1½	6	2500	400	-450/+750	3½	2½	13	17
<b>Style 981 - Series 900 with no. 8 orifice (0.307 sq. in.) and 1500 psig maximum set pressure</b>										
9811( )5MF	1½	2	7	1500	400	-450/+750	4½	3¼	16¾	33
9811( )6MF	2	2	7	1500	400	-450/+750	4½	3¼	16¾	33
9811( )5FF	1½	2	7	1500	400	-450/+750	3½	3¼	15¾	33
9811( )6FF	2	2	7	1500	400	-450/+750	4	3¼	15¾	33
<b>Style 991 - Series 900 with no. 9 orifice (0.503 sq. in.) and 1500 psig maximum set pressure</b>										
9911( )7MF	1½	2½	7	1500	400	-450/+750	4½	3¼	16¾	32
9911( )7FF	1½	2½	7	1500	400	-450/+750	3½	3¼	15¾	32

\* Consult your sales representative for availability of no. 5 (0.074 sq. in.) orifice with FNPT inlet.

#### NOTES

- Minimum/maximum set pressures and temperatures shown apply to metal seated valves only. Refer to page 5 for pressure and temperature limits for soft seat construction.
- Dimension 'C' shown is for Type A cap.  
For Type B cap, add ¼ in. to 'C' dimension (an additional 2 in. is required for test rod head clearance).  
For Type D cap, add ⅝ in. to 'C' dimension.  
For Type E cap, add ⅞ in. to 'C' dimension (an additional 2 in. is required for test rod head clearance).
- Maximum set pressure for steam service is 1000 psig.
- Valves set below 15 psig cannot be stamped with the ASME Code Symbol. Only metal seated valves may be set below 15 psig. For set pressure applications below the published minimum values, consult your sales representative.

# CROSBY OMNI-TRIM® SPECIFICATIONS

## SERIES 900 OMNI-TRIM® FLANGED CONNECTIONS - USCS (U.S. CUSTOMARY SYSTEM) UNITS

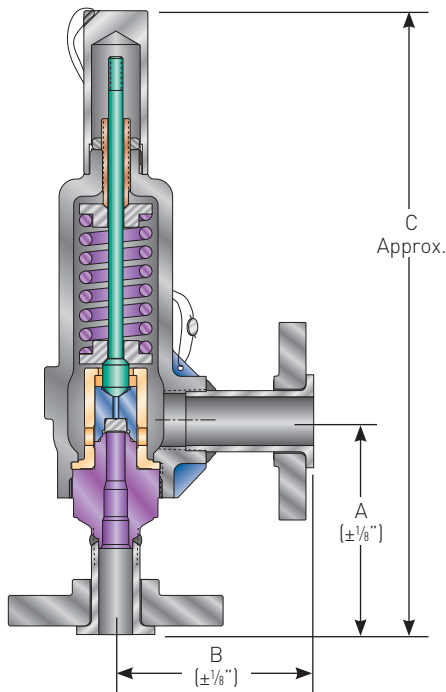

Lap Joint Inlet Flange X Lap Joint Outlet Flange

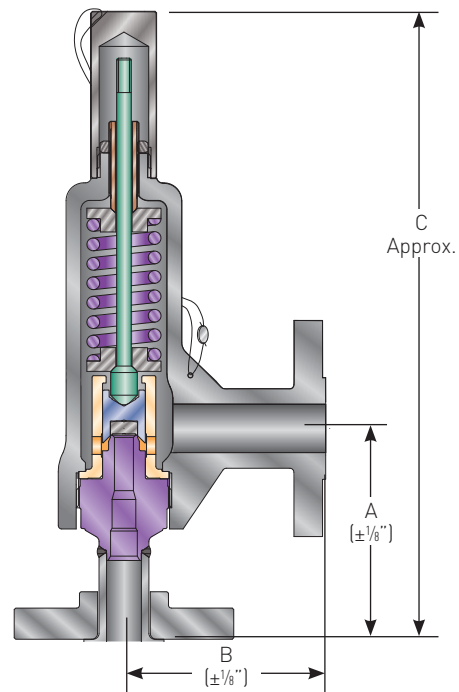

Lap joint x Integral-A cast outlet flange connections<sup>(8)</sup>

### SERIES 900 DIMENSIONS AND WEIGHTS, PRESSURE/TEMPERATURE RATINGS (continued next page)

Valve style number	Connection size (NPS)		Std. ANSI lap joint stub end flanges <sup>(4)</sup>		Maximum <sup>(1,2,6)</sup> set pressure at 100°F (psig)	Maximum outlet pressure (psig)	Dimensions (in.)			Approx. weight (lbs)	
	Inlet	Outlet	Inlet	Outlet			A	B	C <sup>(5)</sup>		
<b>Style 951 - Series 900 with no. 5 orifice (0.074 sq. in.)</b>											
9511( )011	1/2	1	150	150	285	285	4 1/4	4	11 <sup>11/16</sup>	10	
9511( )021	1/2	1	300	150	740	285	4 1/4	4	11 <sup>11/16</sup>	11	
9511( )031	1/2	1	600	150	1480	285	4 1/4	4	11 <sup>11/16</sup>	11	
9511( )111	3/4	1	150	150	285	285	4 1/4	4	11 <sup>11/16</sup>	11	
9511( )121	3/4	1	300	150	740	285	4 1/4	4	11 <sup>11/16</sup>	12	
9511( )131	3/4	1	600	150	1480	285	4 1/4	4	11 <sup>11/16</sup>	12	
9511( )211	1	1	150	150	285	285	4 1/2	4	11 <sup>15/16</sup>	12	
9511( )221	1	1	300	150	740	285	4 1/2	4	11 <sup>15/16</sup>	13	
9511( )231	1	1	600	150	1480	285	4 1/2	4	11 <sup>15/16</sup>	13	
<b>Style 955 - Series 900 with no. 5 orifice (0.074 sq. in.)</b>											
9551( )142	3/4	1	1500	<sup>(3)</sup>	3705	400 <sup>(3)</sup>	5 1/2	4 1/2	14 <sup>5/16</sup>	19	
9551( )152	3/4	1	2500	<sup>(3)</sup>	5000	400 <sup>(3)</sup>	5 1/2	4 1/2	14 <sup>5/16</sup>	21	
9551( )242	1	1	1500	<sup>(3)</sup>	3705	400 <sup>(3)</sup>	5 3/4	4 1/2	14 <sup>9/16</sup>	21	
9551( )252	1	1	2500	<sup>(3)</sup>	5000	400 <sup>(3)</sup>	5 3/4	4 1/2	14 <sup>9/16</sup>	25	

### NOTES

- Maximum set pressures shown are based on carbon steel flanges. Pressure limits for 316 SS flanges may be lower. Consult your sales representative.
- Maximum set pressures apply to metal seated valves only; refer to page 5 for limits for soft seat construction.
- ANSI CL 300 supplied; however, the maximum back pressure is 400 psig.
- Flanges are supplied with a serrated face per ANSI B16.5. Other facings/standards (i.e., DIN) are also available.
- Dimension 'C' shown is for Type A cap.  
For Type B cap, add 1/4 in. to 'C' dimension (an additional 2 in. is required for test rod head clearance).  
For Type D cap, add 5/8 in. to 'C' dimension.  
For Type E cap, add 7/8 in. to 'C' dimension (an additional 2 in. is required for test rod head clearance).
- Maximum set pressure for steam service is 1000 psig.
- ANSI CI 600 flange integral with base.
- Lap Joint Inlet x Integral Cast Outlet flange design is the standard offering for models 951, 955, 961, 965 & 972.

# CROSBY OMNI-TRIM®

## SPECIFICATIONS

### SERIES 900 DIMENSIONS AND WEIGHTS, PRESSURE/TEMPERATURE RATINGS (continued)

Valve style number	Connection size (NPS)		Std. ANSI lap joint stub end flanges <sup>(4)</sup>		Maximum <sup>(1,2,6)</sup> set pressure at 100°F (psig)	Maximum outlet pressure (psig)	Dimensions (in.)			Approx. weight (lbs)
	Inlet	Outlet	Inlet	Outlet			A	B	C <sup>(5)</sup>	
<b>Style 961 - Series 900 with no. 6 orifice (0.110 sq. in.)</b>										
9611( )011	1/2	1	150	150	285	285	4 3/8	4 1/4	13 3/16	14
9611( )021	1/2	1	300	150	740	285	4 3/8	4 1/4	13 3/16	15
9611( )031	1/2	1	600 <sup>(7)</sup>	150	1480	285	4 3/8	4 1/4	13 3/16	15
9611( )111	3/4	1	150	150	285	285	4 3/8	4 1/4	13 3/16	14
9611( )121	3/4	1	300	150	740	285	4 3/8	4 1/4	13 3/16	15
9611( )131	3/4	1	600	150	1480	285	4 3/8	4 1/4	13 3/16	15
9611( )211	1	1	150	150	285	285	4 5/8	4 1/4	13 7/16	14
9611( )221	1	1	300	150	740	285	4 5/8	4 1/4	13 7/16	16
9611( )231	1	1	600	150	1480	285	4 5/8	4 1/4	13 7/16	16
<b>Style 965 - Series 900 with no. 6 orifice (0.110 sq. in.)</b>										
9651( )142	3/4	1	1500	<sup>(3)</sup>	3705	400 <sup>(3)</sup>	6	5	15 11/16	26
9651( )242	1	1	1500	<sup>(3)</sup>	3705	400 <sup>(3)</sup>	6 1/4	5	15 15/16	29
9651( )252	1	1	2500	<sup>(3)</sup>	5000	400 <sup>(3)</sup>	6 1/4	5	15 15/16	32
9651( )342	1	1 1/2	1500	<sup>(3)</sup>	3705	400 <sup>(3)</sup>	6 1/4	5 3/4	15 15/16	29
9651( )352	1	1 1/2	2500	<sup>(3)</sup>	5000	400 <sup>(3)</sup>	6 1/4	5 3/4	15 15/16	35
<b>Style 972 - Series 900 with no. 7 orifice (0.196 sq. in.)</b>										
9721( )311	1	1 1/2	150	150	285	285	5 1/8	5	14 13/16	24
9721( )321	1	1 1/2	300	150	740	285	5 1/8	5	14 13/16	25
9721( )331	1	1 1/2	600	150	1480	285	5 1/8	5	14 13/16	25
9721( )341	1	1 1/2	1500	<sup>(3)</sup>	2500	400 <sup>(3)</sup>	6	5 3/4	15 11/16	32
9721( )411	1 1/2	1 1/2	150	150	285	285	5 1/2	5	15 3/16	26
9721( )421	1 1/2	1 1/2	300	150	740	285	5 1/2	5	15 3/16	29
9721( )431	1 1/2	1 1/2	600	150	1480	285	5 1/2	5	15 3/16	29
9721( )441	1 1/2	1 1/2	1500	<sup>(3)</sup>	2500	400 <sup>(3)</sup>	6	5 3/4	15 11/16	38
<b>Style 981 - Series 900 with no. 8 orifice (0.307 sq. in.)</b>										
9811( )511	1 1/2	2	150	150	285	285	6 1/2	6	18 7/16	44
9811( )521	1 1/2	2	300	150	740	285	6 1/2	6	18 7/16	47
9811( )531	1 1/2	2	600	150	1480	285	6 1/2	6	18 7/16	47
9811( )611	2	2	150	150	285	285	6 3/4	6	18 11/16	46
9811( )621	2	2	300	150	740	285	6 3/4	6	18 11/16	48
9811( )631	2	2	600	150	1480	285	6 3/4	6	18 11/16	49
<b>Style 991 - Series 900 with no. 9 orifice (0.503 sq. in.)</b>										
9911( )711	1 1/2	2 1/2	150	150	285	285	6 1/2	6 1/2	18 7/16	47
9911( )721	1 1/2	2 1/2	300	150	740	285	6 1/2	6 1/2	18 7/16	50
9911( )731	1 1/2	2 1/2	600	150	1480	285	6 1/2	6 1/2	18 7/16	50

#### NOTES

- Maximum set pressures shown are based on carbon steel flanges. Pressure limits for 316 SS flanges may be lower. Consult your sales representative.
- Maximum set pressures apply to metal seated valves only; refer to page 5 for limits for soft seat construction.
- ANSI CL 300 supplied; however, the maximum back pressure is 400 psig.
- Flanges are supplied with a serrated face per ANSI B16.5. Other facings/standards (i.e., DIN) are also available.
- Dimension 'C' shown is for Type A cap.  
For Type B cap, add 1/4 in. to 'C' dimension (an additional 2 in. is required for test rod head clearance).  
For Type D cap, add 5/8 in. to 'C' dimension.  
For Type E cap, add 7/8 in. to 'C' dimension (an additional 2 in. is required for test rod head clearance).
- Maximum set pressure for steam service is 1000 psig.
- ANSI CI 600 flange integral with base.
- Lap Joint Inlet x Integral Cast Outlet flange design is the standard offering for models 951, 955, 961, 965 & 972.

# CROSBY OMNI-TRIM®

## SPECIFICATIONS

### SERIES 900 OMNI-TRIM® THREADED CONNECTIONS - METRIC UNITS

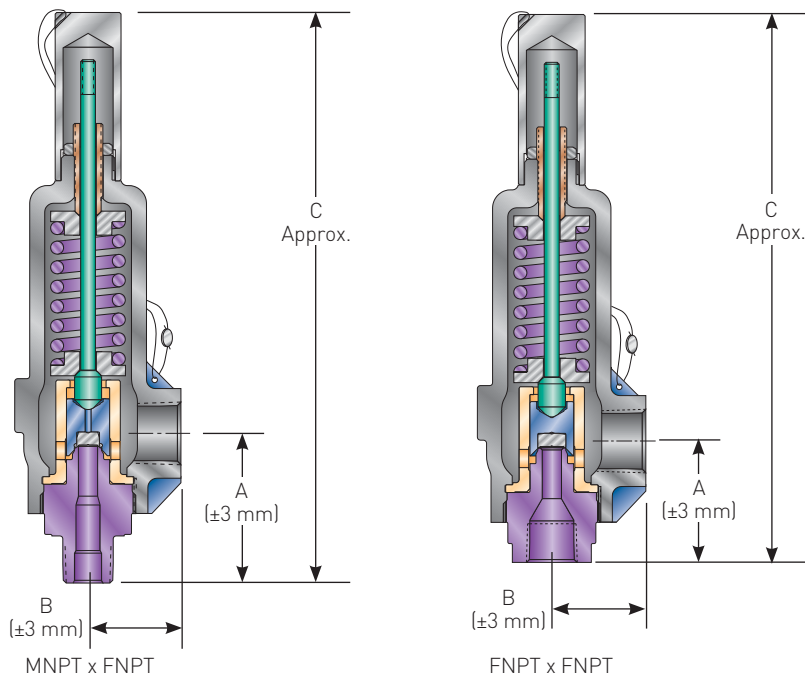

### SERIES 900 DIMENSIONS AND WEIGHTS, PRESSURE/TEMPERATURE RATINGS (continued next page)

Valve style number	Connection size (NPS)		Minimum <sup>(4)</sup> set pressure (barg)	Maximum <sup>(1,3)</sup> set pressure (barg)	Maximum outlet pressure (barg)*	Temperature <sup>(1)</sup> range (°C)	Dimensions (mm)			Approx. weight (kg)
	Inlet	Outlet					A	B	C <sup>(2)</sup>	
<b>Style 951 - Series 900 with no. 5 orifice (47.74 sq. mm)** and 103.42 barg maximum set pressure</b>										
9511( )0MF	1/2	1	0.34	103.42	27.58	-268/+399	76	45	264	3
9511( )1MF	3/4	1	0.34	103.42	27.58	-268/+399	76	45	264	3
9511( )2MF	1	1	0.34	103.42	27.58	-268/+399	83	45	270	3
<b>Style 951 - Series 900 bolted cylinder with No. 5 orifice (47.74 sq. mm) and 103.42 barg max. set pressure</b>										
9511( )199	3/4	1	0.34	103.42	27.58	-268/+399	173	44	362	5
<b>Style 955 - Series 900 with no. 5 orifice (47.74 sq. mm)** and 344.74 barg maximum set pressure</b>										
9551( )0MF	1/2	1	103.49	344.74	27.58	-268/+399	79	49	302	4
9551( )1MF	3/4	1	103.49	344.74	27.58	-268/+399	79	49	302	4
9551( )2MF	1	1	103.49	344.74	27.58	-268/+399	86	49	308	4
<b>Style 961 - Series 900 with no. 6 orifice (70.96 sq. mm) and 103.42 barg maximum set pressure</b>										
9611( )0MF	1/2	1	0.34	103.42	27.58	-268/+399	79	49	302	4
9611( )1MF	3/4	1	0.34	103.42	27.58	-268/+399	79	49	302	4
9611( )2MF	1	1	0.34	103.42	27.58	-268/+399	86	49	308	4
9611( )1FF	3/4	1	0.34	103.42	27.58	-268/+399	64	49	286	4
9611( )2FF	1	1	0.34	103.42	27.58	-268/+399	73	49	295	4

\* To obtain units in kPa, multiply barg units by 100.

\*\*Consult your sales representative for availability of no. 5 (47.74 sq. mm) orifice with FNPT inlet.

### NOTES

- Minimum/maximum set pressures and temperatures shown apply to metal seated valves only. Refer to page 5 for pressure and temperature limits for soft seat construction.
- Dimension 'C' shown is for Type A cap.  
For Type B cap, add 6 mm to 'C' dimension (an additional 51 mm is required for test rod head clearance).  
For Type D cap, add 16 mm to 'C' dimension.  
For Type E cap, add 22 mm to 'C' dimension (an additional 51 mm is required for test rod head clearance).
- Maximum set pressure for steam service is 68.95 barg.
- Valves set below 1.03 barg cannot be stamped with the ASME Code Symbol. Only metal seated valves may be set below 1.03 barg.

# CROSBY OMNI-TRIM®

## SPECIFICATIONS

### SERIES 900 DIMENSIONS AND WEIGHTS, PRESSURE/TEMPERATURE RATINGS (continued)

Valve style number	Connection size (NPS)		Minimum <sup>(4)</sup> set pressure (barg)	Maximum <sup>(1,3)</sup> set pressure (barg)	Maximum outlet pressure (barg)*	Temperature <sup>(1)</sup> range (°C)	Dimensions (mm)			Approx. weight (kg)
	Inlet	Outlet					A	B	C <sup>(2)</sup>	
<b>Style 965 - Series 900 with no. 6 orifice (70.96 sq. mm) and 344.74 barg maximum set pressure</b>										
9651( )1MF	¾	1	103.49	344.74	27.58	-268/+399	89	64	333	7
9651( )2MF	1	1	103.49	344.74	27.58	-268/+399	95	64	340	7
9651( )3MF	1	1½	103.49	344.74	27.58	-268/+399	95	64	340	7
9651( )1FF	¾	1	103.49	344.74	27.58	-268/+399	73	64	318	7
9651( )2FF	1	1	103.49	344.74	27.58	-268/+399	79	64	324	7
9651( )3FF	1	1½	103.49	344.74	27.58	-268/+399	79	64	324	7
<b>Style 972 - Series 900 with no. 7 orifice (126.4 sq. mm) and 172.36 barg maximum set pressure</b>										
9721( )3MF	1	1½	0.41	172.36	27.58	-268/+399	95	64	340	8
9721( )4MF	1½	1½	0.41	172.36	27.58	-268/+399	95	64	340	8
9721( )3FF	1	1½	0.41	172.36	27.58	-268/+399	79	64	324	8
9721( )4FF	1½	1½	0.41	172.36	27.58	-268/+399	86	64	330	8
<b>Style 981 - Series 900 with no. 8 orifice (198.0 sq. mm) and 103.42 barg maximum set pressure</b>										
9811( )5MF	1½	2	0.48	103.42	27.58	-268/+399	114	83	416	15
9811( )6MF	2	2	0.48	103.42	27.58	-268/+399	114	83	416	15
9811( )5FF	1½	2	0.48	103.42	27.58	-268/+399	98	83	400	15
9811( )6FF	2	2	0.48	103.42	27.58	-268/+399	102	83	403	15
<b>Style 991 - Series 900 with no. 9 orifice (324.5 sq. mm) and 103.42 barg maximum set pressure</b>										
9911( )7MF	1½	2½	0.48	103.42	27.58	-268/+399	114	83	416	15
9911( )7FF	1½	2½	0.48	103.42	27.58	-268/+399	98	83	400	15

\* To obtain units in kPa, multiply barg units by 100.

\*\* Consult your sales representative for availability of no. 5 (47.74 sq. mm) orifice with FNPT inlet.

#### NOTES

1. Minimum/maximum set pressures and temperatures shown apply to metal seated valves only. Refer to page 5 for pressure and temperature limits for soft seat construction.
2. Dimension 'C' shown is for Type A cap.  
For Type B cap, add 6 mm to 'C' dimension (an additional 51 mm is required for test rod head clearance).  
For Type D cap, add 16 mm to 'C' dimension.  
For Type E cap, add 22 mm to 'C' dimension (an additional 51 mm is required for test rod head clearance).
3. Maximum set pressure for steam service is 68.95 barg.
4. Valves set below 1.03 barg cannot be stamped with the ASME Code Symbol. Only metal seated valves may be set below 1.03 barg.

# CROSBY OMNI-TRIM®

## SPECIFICATIONS

### SERIES 900 OMNI-TRIM® FLANGED CONNECTIONS - METRIC UNITS

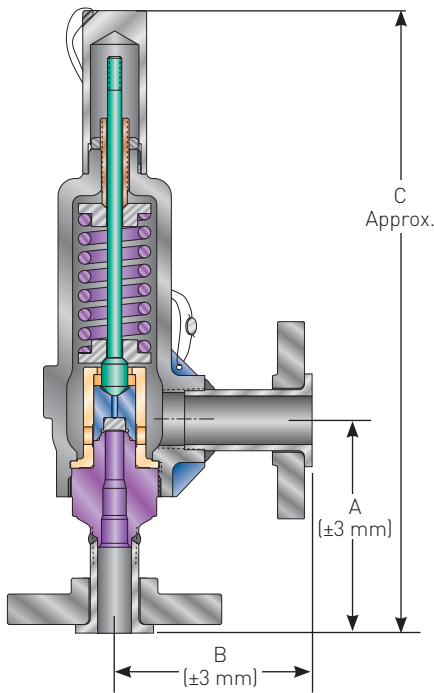

Lap Joint Inlet Flange X Lap Joint Outlet Flange

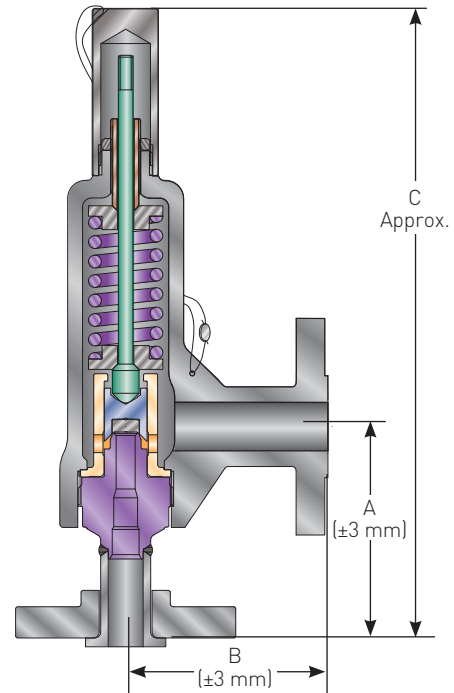

Lap Joint Inlet x Integral Cast Outlet<sup>[8]</sup>

### SERIES 900 DIMENSIONS AND WEIGHTS, PRESSURE/TEMPERATURE RATINGS (continued next page)

Valve style number	Connection size (NPS)		Std. ANSI lap joint stub end flanges <sup>[4]</sup>		Maximum <sup>[1,2,6]</sup> set pressure at 37.8°C (barg)	Maximum outlet pressure (barg)	Dimensions (mm)			Approx. weight (kg)
	Inlet	Outlet	Inlet	Outlet			A	B	C <sup>[5]</sup>	
<b>Style 951 - Series 900 with no. 5 orifice (47.74 sq. mm)</b>										
9511( )011	½	1	150	150	19.65	19.65	108	102	297	5
9511( )021	½	1	300	150	51.02	19.65	108	102	297	5
9511( )031	½	1	600	150	102.04	19.65	108	102	297	5
9511( )111	¾	1	150	150	19.65	19.65	108	102	297	5
9511( )121	¾	1	300	150	51.02	19.65	108	102	297	6
9511( )131	¾	1	600	150	102.04	19.65	108	102	297	6
9511( )211	1	1	150	150	19.65	19.65	114	102	303	5
9511( )221	1	1	300	150	51.02	19.65	114	102	303	6
9511( )231	1	1	600	150	102.04	19.65	114	102	303	6
<b>Style 955 - Series 900 with no. 5 orifice (47.74 sq. mm)</b>										
9551( )142	¾	1	1500	<sup>[3]</sup>	255.45	27.58 <sup>[3]</sup>	140	114	364	8
9551( )152	¾	1	2500	<sup>[3]</sup>	344.74	27.58 <sup>[3]</sup>	140	114	364	10
9551( )242	1	1	1500	<sup>[3]</sup>	255.45	27.58 <sup>[3]</sup>	146	114	370	10
9551( )252	1	1	2500	<sup>[3]</sup>	344.74	27.58 <sup>[3]</sup>	146	114	370	11

### NOTES

- Maximum set pressures shown are based on carbon steel flanges. Pressure limits for 316 SS flanges may be lower. Consult your sales representative.
- Maximum set pressures apply to metal seated valves only; refer to page 5 for limits for soft seat construction.
- ANSI CL 300 supplied; however, the maximum back pressure is 27.58 barg.
- Flanges are supplied with a serrated face per ANSI B16.5. Other facings/standards (i.e., DIN) are also available.
- Dimension 'C' shown is for Type A cap.  
For Type B cap, add 6 mm to 'C' dimension (an additional 51 mm is required for test rod head clearance).  
For Type D cap, add 16 mm to 'C' dimension.  
For Type E cap, add 22 mm to 'C' dimension (an additional 51 mm is required for test rod head clearance).
- Maximum set pressure for steam service is 68.95 barg.
- ANSI CI 600 flange integral with base.
- Lap Joint Inlet x Integral Cast Outlet flange design is the standard offering for models 951, 955, 961, 965 & 972.

# CROSBY OMNI-TRIM®

## SPECIFICATIONS

### SERIES 900 DIMENSIONS AND WEIGHTS, PRESSURE/TEMPERATURE RATINGS (continued)

Valve style number	Connection size (NPS)		Std. ANSI lap joint stub end flanges <sup>(4)</sup>		Maximum <sup>(1,2,4)</sup> set pressure at 37.8°C (barg)	Maximum outlet pressure (barg)	Dimensions (mm)			Approx. weight (kg)
	Inlet	Outlet	Inlet	Outlet			A	B	C <sup>(5)</sup>	
<b>Style 961 - Series 900 with no. 6 orifice (70.96 sq. mm)</b>										
9611( )011	1/2	1	150	150	19.65	19.65	111	108	335	6
9611( )021	1/2	1	300	150	51.02	19.65	111	108	335	7
9611( )031	1/2	1	6007	150	102.04	19.65	111	108	335	7
9611( )111	3/4	1	150	150	19.65	19.65	111	108	335	6
9611( )121	3/4	1	300	150	51.02	19.65	111	108	335	7
9611( )131	3/4	1	600	150	102.04	19.65	111	108	335	7
9611( )211	1	1	150	150	19.65	19.65	117	108	341	7
9611( )221	1	1	300	150	51.02	19.65	117	108	341	7
9611( )231	1	1	600	150	102.04	19.65	117	108	341	7
<b>Style 965 - Series 900 with no. 6 orifice (70.96 sq. mm)</b>										
9651( )142	3/4	1	1500	(3)	255.45	27.58 <sup>(3)</sup>	152	127	398	12
9651( )242	1	1	1500	(3)	255.45	27.58 <sup>(3)</sup>	159	127	405	13
9651( )252	1	1	2500	(3)	344.74	27.58 <sup>(3)</sup>	159	127	405	14
9651( )342	1	1 1/2	1500	(3)	255.45	27.58 <sup>(3)</sup>	159	146	405	13
9651( )352	1	1 1/2	2500	(3)	344.74	27.58 <sup>(3)</sup>	159	146	405	16
<b>Style 972 - Series 900 with no. 7 orifice (126.4 sq. mm)</b>										
9721( )311	1	1 1/2	150	150	19.65	19.65	130	127	376	11
9721( )321	1	1 1/2	300	150	51.02	19.65	130	127	376	11
9721( )331	1	1 1/2	600	150	102.04	19.65	130	127	376	11
9721( )342	1	1 1/2	1500	(3)	172.36	27.58 <sup>(3)</sup>	152	146	398	15
9721( )411	1 1/2	1 1/2	150	150	19.65	19.65	140	127	386	12
9721( )421	1 1/2	1 1/2	300	150	51.02	19.65	140	127	386	13
9721( )431	1 1/2	1 1/2	600	150	102.04	19.65	140	127	386	13
9721( )442	1 1/2	1 1/2	1500	(3)	172.36	27.58 <sup>(3)</sup>	152	146	398	17
<b>Style 981 - Series 900 with no. 8 orifice (198.0 sq. mm)</b>										
9811( )511	1 1/2	2	150	150	19.65	19.65	165	152	468	20
9811( )521	1 1/2	2	300	150	51.02	19.65	165	152	468	21
9811( )531	1 1/2	2	600	150	102.04	19.65	165	152	468	21
9811( )611	2	2	150	150	19.65	19.65	171	152	475	21
9811( )621	2	2	300	150	51.02	19.65	171	152	475	22
9811( )631	2	2	600	150	102.04	19.65	171	152	475	22
<b>Style 991 - Series 900 with no. 9 orifice (324.5 sq. mm)</b>										
9911( )711	1 1/2	2 1/2	150	150	19.65	19.65	165	165	468	21
9911( )721	1 1/2	2 1/2	300	150	51.02	19.65	165	165	468	23
9911( )731	1 1/2	2 1/2	600	150	102.04	19.65	165	165	468	23

#### NOTES

- Maximum set pressures shown are based on carbon steel flanges. Pressure limits for 316 SS flanges may be lower. Consult your sales representative.
- Maximum set pressures apply to metal seated valves only; refer to page 5 for limits for soft seat construction.
- ANSI CL 300 supplied; however, the maximum back pressure is 27.58 barg.
- Flanges are supplied with a serrated face per ANSI B16.5. Other facings/standards (i.e., DIN) are also available.
- Dimension 'C' shown is for Type A cap.  
For Type B cap, add 6 mm to 'C' dimension (an additional 51 mm is required for test rod head clearance).  
For Type D cap, add 16 mm to 'C' dimension.  
For Type E cap, add 22 mm to 'C' dimension (an additional 51 mm is required for test rod head clearance).
- Maximum set pressure for steam service is 68.95 barg.
- ANSI CI 600 flange integral with base.
- Lap Joint Inlet x Integral Cast Outlet flange design is the standard offering for models 951, 955, 961, 965 & 972.



# CROSBY OMNI-TRIM®

## SPECIFICATIONS

SERIES BP THREADED CONNECTIONS (NPT) - USCS UNITS (U.S. CUSTOMARY SYSTEM) (METRIC UNITS)

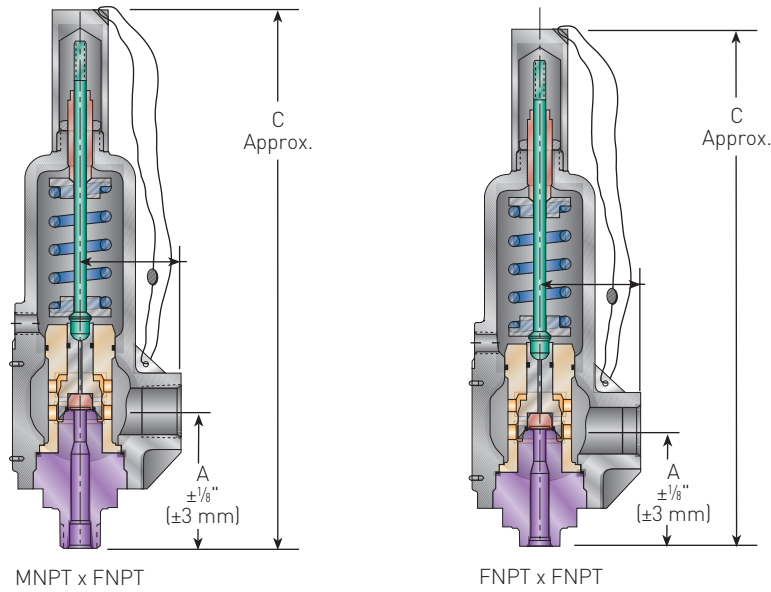

### SERIES BP DIMENSIONS AND WEIGHTS, PRESSURE/TEMPERATURE RATINGS

Valve style number	Connection size (NPS)		Minimum set pressure psig (barg)	Maximum set pressure psig (barg)	Maximum outlet pressure (barg)	Temperature range °F (°C) <sup>(1)</sup>	Dimensions (mm)			Approx. weight <sup>(3)</sup> lbs (kg)
	Inlet	Outlet					A	B	C <sup>(2)</sup>	
<b>Style BP5 - series BP with no. 5 orifice [0.074 in<sup>2</sup> [47.7 mm<sup>2</sup>]] and 1500 psig (103.44 barg) maximum set pressure</b>										
BP51( ) ( )1MF	3/4	1	50 (3.45)	1500 (103.44)	400 (27.58)	-20/+400 (-28/+204)	3 3/8 (86)	2 1/2 (64)	13 3/8 (340)	14 (6)
BP51( ) ( )2MF	1	1	50 (3.45)	1500 (103.44)	400 (27.58)	-20/+400 (-28/+204)	3 3/8 (92)	2 1/2 (64)	13 3/8 (346)	14 (6)
BP51( ) ( )1FF	3/4	1	50 (3.45)	1500 (103.44)	400 (27.58)	-20/+400 (-28/+204)	2 3/4 (70)	2 1/2 (64)	12 3/4 (324)	14 (6)
BP51( ) ( )2FF	1	1	50 (3.45)	1500 (103.44)	400 (27.58)	-20/+400 (-28/+204)	3 (736)	2 1/2 (64)	13 (330)	14 (6)
<b>Style BP6 - series BP with no. 6 orifice [0.110 in<sup>2</sup> [70.96 mm<sup>2</sup>]] and 1500 psig (103.44 barg) maximum set pressure</b>										
BP61( ) ( )1MF	3/4	1 1/2	50 (3.45)	1500 (103.44)	400 (27.58)	-20/+400 (-28/+204)	3 3/8 (86)	2 1/2 (64)	13 3/8 (340)	14 (6)
BP61( ) ( )2MF	1	1 1/2	50 (3.45)	1500 (103.44)	400 (27.58)	-20/+400 (-28/+204)	3 3/8 (92)	2 1/2 (64)	13 3/8 (346)	14 (6)
BP61( ) ( )1FF	3/4	1 1/2	50 (3.45)	1500 (103.44)	400 (27.58)	-20/+400 (-28/+204)	2 3/4 (70)	2 1/2 (64)	12 3/4 (324)	14 (6)
BP61( ) ( )2FF	1	1 1/2	50 (3.45)	1500 (103.44)	400 (27.58)	-20/+400 (-28/+204)	3 (736)	2 1/2 (64)	13 (330)	14 (6)

### NOTES

- Refer to page 7 for soft seat temperature limits.
- Dimension 'C' shown is for Type A cap.  
For Type B cap, add 1/4 in. (6 mm) to 'C' dimension (an additional 2 in. [51 mm] is required for test rod head clearance).  
For Type D cap, add 5/8 in. (16 mm) to 'C' dimension.  
For Type E cap, add 7/8 in. (22 mm) to 'C' dimension (an additional 2 in. [51 mm] is required for test rod head clearance).
- Add 1.6 lbs (0.7 kg) for Type D and E caps.

# CROSBY OMNI-TRIM®

## SPECIFICATIONS

SERIES BP FLANGED CONNECTIONS (NPT) - USCS UNITS (U.S. CUSTOMARY SYSTEM) (METRIC UNITS)

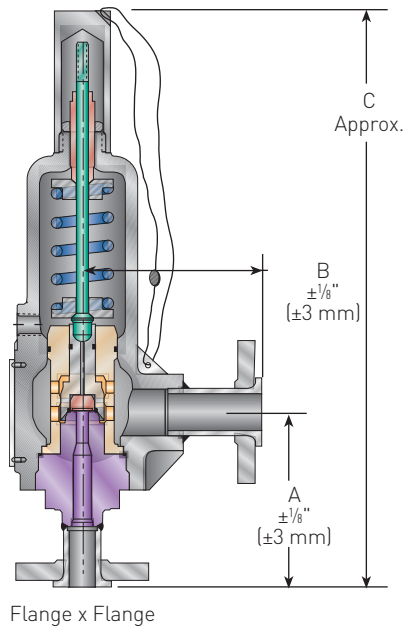

### SERIES BP DIMENSIONS AND WEIGHTS, PRESSURE/TEMPERATURE RATINGS

Valve style number	Connection size (NPS)		Std. ANSI <sup>(2)</sup> lap joint stub end flanges		Maximum <sup>(1)</sup> set pressure at 100°F (37.8°C) psig (barg)	Maximum outlet pressure psig (barg)	Dimensions (mm)			Approx. weight <sup>(4)</sup> lbs (kg)
	Inlet	Outlet	Inlet	Outlet			A	B	C <sup>(3)</sup>	
<b>Style BP5 - Series BP with no. 5 orifice (0.074 in<sup>2</sup> [47.74 sq. mm])</b>										
BP51( ) ( )111	3/4	1	150	150	285 (19.65)	285 (19.65)	4 3/8 (117)	4 3/4 (121)	14 5/8 (371)	18 (8)
BP51( ) ( )121	3/4	1	300	150	740 (51.02)	285 (19.65)	4 3/8 (117)	4 3/4 (121)	14 5/8 (371)	20 (9)
BP51( ) ( )131	3/4	1	600	150	1480 (102.04)	285 (19.65)	4 3/8 (117)	4 3/4 (121)	14 5/8 (371)	20 (9)
BP51( ) ( )142	3/4	1	1500	300	1500 (19.65)	400 [27.85] <sup>(5)</sup>	5 (143)	5 (127)	15 5/8 (397)	24 (11)
BP51( ) ( )211	1	1	150	150	285 (19.65)	285 (19.65)	4 3/8 (124)	4 3/4 (121)	14 7/8 (378)	19 (9)
BP51( ) ( )221	1	1	300	150	740 (51.02)	285 (19.65)	4 3/8 (124)	4 3/4 (121)	14 7/8 (378)	20 (9)
BP51( ) ( )231	1	1	600	150	1480 (102.04)	285 (19.65)	4 3/8 (124)	4 3/4 (121)	14 7/8 (378)	20 (9)
BP51( ) ( )242	1	1	1500	300	1500 (19.65)	400 [27.85] <sup>(5)</sup>	5 (143)	5 (127)	15 5/8 (403)	26 (12)
<b>Style BP6 - Series BP with no. 6 orifice (0.110 in<sup>2</sup> [70.96 mm<sup>2</sup>])</b>										
BP61( ) ( )111	3/4	1	150	150	285 (19.65)	285 (19.65)	4 3/8 (117)	4 3/4 (121)	14 5/8 (371)	18 (8)
BP61( ) ( )121	3/4	1	300	150	740 (51.02)	285 (19.65)	4 3/8 (117)	4 3/4 (121)	14 5/8 (371)	20 (9)
BP61( ) ( )131	3/4	1	600	150	1480 (102.04)	285 (19.65)	4 3/8 (117)	4 3/4 (121)	14 5/8 (371)	20 (9)
BP61( ) ( )142	3/4	1	1500	300	1500 (19.65)	400 [27.85] <sup>(5)</sup>	5 (143)	5 (127)	15 5/8 (397)	24 (11)
BP61( ) ( )211	1	1	150	150	285 (19.65)	285 (19.65)	4 3/8 (124)	4 3/4 (121)	14 7/8 (378)	19 (9)
BP61( ) ( )221	1	1	300	150	740 (51.02)	285 (19.65)	4 3/8 (124)	4 3/4 (121)	14 7/8 (378)	20 (9)
BP61( ) ( )231	1	1	600	150	1480 (102.04)	285 (19.65)	4 3/8 (124)	4 3/4 (121)	14 7/8 (378)	20 (9)
BP61( ) ( )242	1	1	1500	300	1500 (19.65)	400 [27.85] <sup>(5)</sup>	5 (143)	5 (127)	15 5/8 (403)	26 (12)

### NOTES

- Maximum set pressures shown are based on carbon steel flanges. Pressure limits for 316 SS flanges may be lower. Consult your sales representative.
- Flanges are supplied with a serrated face per ANSI B16.5. Other facings/standards (i.e., DIN) are also available.
- Dimension 'C' shown is for Type A cap.  
For Type B cap, add 1/4 in. (6 mm) to 'C' dimension (an additional 2 in. [51 mm] is required for test rod head clearance).  
For Type D cap, add 5/8 in. (16 mm) to 'C' dimension.  
For Type E cap, add 7/8 in. (22 mm) to 'C' dimension (an additional 2 in. [51 mm] is required for test rod head clearance).
- Add 1.6 lbs [0.7 kg] for Type D and E caps.
- ANSI CL 300 supplied; however the maximum back pressure is 400 psig [27.58 barg].

# CROSBY OMNI-TRIM®

## AIR CAPACITIES

SERIES 900 VALVES - USCS (U.S. CUSTOMARY SYSTEM) UNITS

**Note:** For air capacities, USCS units are exact equivalents of imperial units.

### AIR CAPACITIES - SET PRESSURES 5-5000 psig (continued next page)

Set pressure (psig)	Effective area (sq. in.)					Set pressure (psig)	Effective area (sq. in.)				
	0.074	0.110	0.196	0.307	0.503		0.074	0.110	0.196	0.307	0.503
<b>1 psi incr.<sup>(1)</sup></b>	<b>1.4</b>	<b>2.1</b>	<b>3.8</b>	<b>6.1</b>	<b>10.0</b>	<b>1 psi incr.<sup>(1)</sup></b>	<b>1.4</b>	<b>2.1</b>	<b>3.8</b>	<b>6.1</b>	<b>10.0</b>
<b>5 psi incr.</b>	<b>7.4</b>	<b>10.9</b>	<b>19.4</b>	<b>30.7</b>	<b>50.1</b>	<b>5 psi incr.</b>	<b>7.4</b>	<b>10.9</b>	<b>19.4</b>	<b>30.7</b>	<b>50.1</b>
5	34.2	<b>50.4</b>				280	438	<b>645</b>	<b>1140</b>	<b>1801</b>	<b>2943</b>
6	35.7	<b>52.6</b>	<b>93.0</b>			300	468	<b>689</b>	<b>1218</b>	<b>1924</b>	<b>3144</b>
7	37.2	<b>54.8</b>	<b>96.9</b>	<b>153</b>	<b>250</b>	320	498	<b>733</b>	<b>1295</b>	<b>2047</b>	<b>3344</b>
8	38.7	<b>57.1</b>	<b>100</b>	<b>159</b>	<b>260</b>	340	528	<b>777</b>	<b>1373</b>	<b>2170</b>	<b>3545</b>
9	40.3	<b>59.3</b>	<b>104</b>	<b>165</b>	<b>270</b>	360	557	<b>821</b>	<b>1451</b>	<b>2293</b>	<b>3746</b>
10	41.8	<b>61.5</b>	<b>108</b>	<b>171</b>	<b>280</b>	380	587	<b>865</b>	<b>1528</b>	<b>2415</b>	<b>3946</b>
15	44.4	<b>65.3</b>	<b>115</b>	<b>182</b>	<b>298</b>	400	617	<b>909</b>	<b>1606</b>	<b>2538</b>	<b>4147</b>
20	51.2	<b>75.3</b>	<b>133</b>	<b>210</b>	<b>343</b>	420	647	<b>953</b>	<b>1684</b>	<b>2661</b>	<b>4348</b>
30	64.7	<b>95.3</b>	<b>168</b>	<b>266</b>	<b>435</b>	440	677	<b>997</b>	<b>1762</b>	<b>2784</b>	<b>4548</b>
40	79.7	<b>117</b>	<b>207</b>	<b>327</b>	<b>535</b>	460	707	<b>1041</b>	<b>1839</b>	<b>2907</b>	<b>4749</b>
50	94.6	<b>139</b>	<b>246</b>	<b>389</b>	<b>635</b>	480	737	<b>1085</b>	<b>1917</b>	<b>3030</b>	<b>4950</b>
60	109	<b>161</b>	<b>285</b>	<b>450</b>	<b>736</b>	500	767	<b>1129</b>	<b>1995</b>	<b>3152</b>	<b>5151</b>
70	124	<b>183</b>	<b>324</b>	<b>511</b>	<b>836</b>	520	797	<b>1173</b>	<b>2073</b>	<b>3275</b>	<b>5351</b>
80	139	<b>205</b>	<b>362</b>	<b>573</b>	<b>936</b>	540	826	<b>1217</b>	<b>2150</b>	<b>3398</b>	<b>5552</b>
90	154	<b>227</b>	<b>401</b>	<b>634</b>	<b>1037</b>	560	856	<b>1261</b>	<b>2228</b>	<b>3521</b>	<b>5753</b>
100	169	<b>249</b>	<b>440</b>	<b>696</b>	<b>1137</b>	580	886	<b>1305</b>	<b>2306</b>	<b>3644</b>	<b>5953</b>
120	199	<b>293</b>	<b>518</b>	<b>819</b>	<b>1338</b>	600	916	<b>1349</b>	<b>2384</b>	<b>3767</b>	<b>6154</b>
140	229	<b>337</b>	<b>596</b>	<b>941</b>	<b>1538</b>	620	946	<b>1393</b>	<b>2461</b>	<b>3889</b>	<b>6355</b>
160	259	<b>381</b>	<b>673</b>	<b>1064</b>	<b>1739</b>	640	976	<b>1437</b>	<b>2539</b>	<b>4012</b>	<b>6555</b>
180	288	<b>425</b>	<b>751</b>	<b>1187</b>	<b>1940</b>	660	1006	<b>1481</b>	<b>2617</b>	<b>4135</b>	<b>6756</b>
200	318	<b>469</b>	<b>829</b>	<b>1310</b>	<b>2140</b>	680	1036	<b>1525</b>	<b>2695</b>	<b>4258</b>	<b>6957</b>
220	348	<b>513</b>	<b>907</b>	<b>1433</b>	<b>2341</b>	700	1065	<b>1569</b>	<b>2772</b>	<b>4381</b>	<b>7157</b>
240	378	<b>557</b>	<b>984</b>	<b>1556</b>	<b>2542</b>	720	1095	<b>1613</b>	<b>2850</b>	<b>4504</b>	<b>7358</b>
260	408	<b>601</b>	<b>1062</b>	<b>1678</b>	<b>2742</b>	740	1125	<b>1657</b>	<b>2928</b>	<b>4626</b>	<b>7559</b>

### NOTES

1. Not valid below 30 psig set pressure.
2. Capacities below 30 psig set pressure are calculated at 3 psi overpressure.
3. The scope of the ASME Code, Section VIII, does not include pressures below 15 psig and therefore pressure relief valves set below 15 psig are not stamped with the ASME Code Symbol.

**Capacity in standard cubic feet per minute of air at 60°F and 10% overpressure. Valve discharging to atmospheric pressure.<sup>(2)</sup>**

Capacities certified by the National Board of Boiler and Pressure Vessel Inspectors and in accordance with the ASME Boiler and Pressure Vessel Code, Section VIII.

# CROSBY OMNI-TRIM®

## AIR CAPACITIES

### AIR CAPACITIES - SET PRESSURES 5-5000 psig (continued)

Set pressure (psig)	Effective area (sq. in.)					Set pressure (psig)	Effective area (sq. in.)				
	0.074	0.110	0.196	0.307	0.503		0.074	0.110	0.196	0.307	0.503
<b>1 psi incr.<sup>(1)</sup></b>	<b>1.4</b>	<b>2.1</b>	<b>3.8</b>	<b>6.1</b>	<b>10.0</b>	<b>1 psi incr.<sup>(1)</sup></b>	<b>1.4</b>	<b>2.1</b>	<b>3.8</b>	<b>6.1</b>	<b>10.0</b>
<b>5 psi incr.</b>	<b>7.4</b>	<b>10.9</b>	<b>19.4</b>	<b>30.7</b>	<b>50.1</b>	<b>5 psi incr.</b>	<b>7.4</b>	<b>10.9</b>	<b>19.4</b>	<b>30.7</b>	<b>50.1</b>
760	1155	1701	3006	4749	7759	2200	3307	4869	8603		
780	1185	1745	3083	4872	7960	2300	3456	5089	8991		
800	1215	1789	3161	4995	8161	2400	3606	5309	9380		
820	1245	1833	3239	5118	8361	2500	3755	5529	9769		
840	1275	1877	3316	5241	8562	2600	3905	5749			
860	1305	1921	3394	5363	8763	2700	4054	5969			
880	1334	1965	3472	5486	8963	2800	4203	6189			
900	1364	2009	3550	5609	9164	2900	4353	6409			
920	1394	2053	3627	5732	9365	3000	4502	6629			
940	1424	2097	3705	5855	9565	3100	4652	6849			
960	1454	2141	3783	5978	9766	3200	4801	7069			
980	1484	2185	3861	6100	9967	3300	4951	7288			
1000	1514	2229	3938	6223	10167	3400	5100	7508			
1100	1663	2449	4327	6837	11171	3500	5249	7728			
1200	1813	2669	4716	7452	12174	3600	5399	7948			
1300	1962	2889	5104	8066	13178	3700	5548	8168			
1400	2111	3109	5493	8680	14181	3800	5698	8388			
1500	2261	3329	5882	9294	15184	3900	5847	8608			
1600	2410	3549	6271			4000	5997	8828			
1700	2560	3769	6659			4200	6295	9268			
1800	2709	3989	7048			4400	6594	9708			
1900	2859	4209	7437			4600	6893	10148			
2000	3008	4429	7825			4800	7192	10588			
2100	3157	4649	8214			5000	7491	11028			

### NOTES

1. Not valid below 30 psig set pressure.
2. Capacities below 30 psig set pressure are calculated at 3 psi overpressure.
3. The scope of the ASME Code, Section VIII, does not include pressures below 15 psig and therefore pressure relief valves set below 15 psig are not stamped with the ASME Code Symbol.

### Capacity in standard cubic feet per minute of air at 60°F and 10% overpressure. Valve discharging to atmospheric pressure.<sup>(2)</sup>

Capacities certified by the National Board of Boiler and Pressure Vessel Inspectors and in accordance with the ASME Boiler and Pressure Vessel Code, Section VIII.

# CROSBY OMNI-TRIM®

## SATURATED STEAM CAPACITIES

UNFIRED PRESSURE VESSEL SERVICE SERIES 900 VALVES USCS (U.S. CUSTOMARY SYSTEM) UNITS

**Note:** for steam capacities, USCS units are exact equivalents of imperial units.

### SATURATED STEAM CAPACITIES - SET PRESSURES 5-1000 psig (continued next page)

Set pressure (psig)	Effective area (sq. in.)					Set pressure (psig)	Effective area (sq. in.)				
	0.074	0.110	0.196	0.307	0.503		0.074	0.110	0.196	0.307	0.503
<b>1 psi incr.<sup>(1)</sup></b>	<b>4.1</b>	<b>6.1</b>	<b>10.9</b>	<b>17.2</b>	<b>28.1</b>	<b>1 psi incr.<sup>(1)</sup></b>	<b>4.1</b>	<b>6.1</b>	<b>10.9</b>	<b>17.2</b>	<b>28.1</b>
<b>5 psi incr.</b>	<b>20.9</b>	<b>30.9</b>	<b>54.6</b>	<b>86.2</b>	<b>140</b>	<b>5 psi incr.</b>	<b>20.9</b>	<b>30.9</b>	<b>54.6</b>	<b>86.2</b>	<b>140</b>
5	96.2	<b>141</b>				160	727	<b>1071</b>	<b>1893</b>	<b>2991</b>	<b>4887</b>
6	100	<b>147</b>	<b>261</b>			170	769	<b>1133</b>	<b>2002</b>	<b>3163</b>	<b>5168</b>
7	104	<b>154</b>	<b>272</b>			180	811	<b>1195</b>	<b>2111</b>	<b>3336</b>	<b>5450</b>
8	108	<b>160</b>	<b>283</b>	<b>447</b>	<b>731</b>	190	853	<b>1256</b>	<b>2220</b>	<b>3508</b>	<b>5732</b>
9	113	<b>166</b>	<b>294</b>	<b>465</b>	<b>760</b>	200	895	<b>1318</b>	<b>2329</b>	<b>3681</b>	<b>6014</b>
10	117	<b>172</b>	<b>305</b>	<b>482</b>	<b>788</b>	210	937	<b>1380</b>	<b>2439</b>	<b>3854</b>	<b>6296</b>
15	124	<b>183</b>	<b>324</b>	<b>512</b>	<b>837</b>	220	979	<b>1442</b>	<b>2548</b>	<b>4026</b>	<b>6578</b>
20	143	<b>211</b>	<b>374</b>	<b>591</b>	<b>966</b>	230	1021	<b>1504</b>	<b>2657</b>	<b>4199</b>	<b>6860</b>
30	182	<b>268</b>	<b>473</b>	<b>748</b>	<b>1222</b>	240	1063	<b>1565</b>	<b>2766</b>	<b>4371</b>	<b>7142</b>
40	224	<b>329</b>	<b>582</b>	<b>920</b>	<b>1504</b>	250	1105	<b>1627</b>	<b>2875</b>	<b>4544</b>	<b>7424</b>
50	266	<b>391</b>	<b>691</b>	<b>1093</b>	<b>1786</b>	260	1147	<b>1689</b>	<b>2985</b>	<b>4716</b>	<b>7706</b>
60	307	<b>453</b>	<b>801</b>	<b>1265</b>	<b>2068</b>	270	1189	<b>1751</b>	<b>3094</b>	<b>4889</b>	<b>7987</b>
70	349	<b>515</b>	<b>910</b>	<b>1438</b>	<b>2349</b>	280	1231	<b>1813</b>	<b>3203</b>	<b>5061</b>	<b>8269</b>
80	391	<b>577</b>	<b>1019</b>	<b>1610</b>	<b>2631</b>	290	1273	<b>1874</b>	<b>3312</b>	<b>5234</b>	<b>8551</b>
90	433	<b>638</b>	<b>1128</b>	<b>1783</b>	<b>2913</b>	300	1315	<b>1936</b>	<b>3421</b>	<b>5406</b>	<b>8833</b>
100	475	<b>700</b>	<b>1237</b>	<b>1956</b>	<b>3195</b>	310	1357	<b>1998</b>	<b>3531</b>	<b>5579</b>	<b>9115</b>
110	517	<b>762</b>	<b>1347</b>	<b>2128</b>	<b>3477</b>	320	1399	<b>2060</b>	<b>3640</b>	<b>5752</b>	<b>9397</b>
120	559	<b>824</b>	<b>1456</b>	<b>2301</b>	<b>3759</b>	330	1441	<b>2122</b>	<b>3749</b>	<b>5924</b>	<b>9679</b>
130	601	<b>886</b>	<b>1565</b>	<b>2473</b>	<b>4041</b>	340	1483	<b>2183</b>	<b>3858</b>	<b>6097</b>	<b>9961</b>
140	643	<b>947</b>	<b>1674</b>	<b>2646</b>	<b>4323</b>	350	1525	<b>2245</b>	<b>3967</b>	<b>6269</b>	<b>10243</b>
150	685	<b>1009</b>	<b>1783</b>	<b>2818</b>	<b>4605</b>	360	1567	<b>2307</b>	<b>4077</b>	<b>6442</b>	<b>10524</b>

#### NOTES

1. Not valid below 30 psig set pressure.
2. Capacities below 30 psig set pressure are calculated at 3 psi overpressure.
3. Maximum set pressure for steam service is 1000 psig.
4. The scope of the ASME Code, Section VIII, does not include pressures below 15 psig and therefore pressure relief valves set below 15 psig are not stamped with the ASME Code Symbol.

#### Capacity in pounds per hour of steam at 10% overpressure. Valve discharging to atmospheric pressure.<sup>(2)</sup>

Capacities certified by the National Board of Boiler and Pressure Vessel Inspectors and in accordance with the ASME Boiler and Pressure Vessel Code, Section VIII.

**CROSBY OMNI-TRIM®**  
SATURATED STEAM CAPACITIES

**SATURATED STEAM CAPACITIES - SET PRESSURES 5-1000 psig (continued)**

Set pressure (psig)	Effective area (sq. in.)					Set pressure (psig)	Effective area (sq. in.)				
	0.074	0.110	0.196	0.307	0.503		0.074	0.110	0.196	0.307	0.503
<b>1 psi incr.<sup>(1)</sup></b>	<b>4.1</b>	<b>6.1</b>	<b>10.9</b>	<b>17.2</b>	<b>28.1</b>	<b>1 psi incr.<sup>(1)</sup></b>	<b>4.1</b>	<b>6.1</b>	<b>10.9</b>	<b>17.2</b>	<b>28.1</b>
<b>5 psi incr.</b>	<b>20.9</b>	<b>30.9</b>	<b>54.6</b>	<b>86.2</b>	<b>140</b>	<b>5 psi incr.</b>	<b>20.9</b>	<b>30.9</b>	<b>54.6</b>	<b>86.2</b>	<b>140</b>
370	1609	2369	4186	6614	10806	640	2742	4038	7134	11273	18418
380	1651	2431	4295	6787	11088	660	2826	4161	7353	11618	18981
390	1693	2492	4404	6959	11370	680	2910	4285	7571	11963	19545
400	1735	2554	4513	7132	11652	700	2994	4408	7790	12308	20109
410	1777	2616	4623	7304	11934	720	3078	4532	8008	12653	20673
420	1819	2678	4732	7477	12216	740	3162	4656	8226	12998	21237
430	1861	2740	4841	7650	12498	760	3246	4779	8445	13344	21800
440	1903	2801	4950	7822	12780	780	3330	4903	8663	13689	22364
450	1945	2863	5059	7995	13062	800	3414	5026	8882	14034	22928
460	1987	2925	5169	8167	13343	820	3498	5150	9100	14379	23492
470	2029	2987	5278	8340	13625	840	3582	5274	9318	14724	24055
480	2071	3049	5387	8512	13907	860	3666	5397	9537	15069	24619
490	2113	3111	5496	8685	14189	880	3750	5521	9755	15414	25183
500	2155	3172	5605	8857	14471	900	3834	5644	9974	15759	25747
520	2239	3296	5824	9202	15035	920	3918	5768	10192	16104	26311
540	2323	3420	6042	9548	15599	940	4002	5892	10410	16449	26874
560	2407	3543	6261	9893	16162	960	4086	6015	10629	16794	27438
580	2491	3667	6479	10238	16726	980	4170	6139	10847	17140	28002
600	2574	3790	6698	10583	17290	1000	4254	6263	11066	17485	28566
620	2658	3914	6916	10928	17854						

**NOTES**

1. Not valid below 30 psig set pressure.
2. Capacities below 30 psig set pressure are calculated at 3 psi overpressure.
3. Maximum set pressure for steam service is 1000 psig.
4. The scope of the ASME Code, Section VIII, does not include pressures below 15 psig and therefore pressure relief valves set below 15 psig are not stamped with the ASME Code Symbol.

**Capacity in pounds per hour of steam at 10% overpressure. Valve discharging to atmospheric pressure.<sup>(2)</sup>**

Capacities certified by the National Board of Boiler and Pressure Vessel Inspectors and in accordance with the ASME Boiler and Pressure Vessel Code, Section VIII.

# CROSBY OMNI-TRIM®

## WATER CAPACITIES

SERIES 900 OMNI-TRIM® VALVES - USCS (U.S. CUSTOMARY SYSTEM) UNITS

**Note:** USCS units for water and liquids are U.S. gallons per minute (1 U.S. gallon equals 0.833 imperial gallon).

### WATER CAPACITIES - DIFFERENTIAL PRESSURES $\Delta P^{(1)}$ 5-5000 psi<sup>(2)</sup> (continued next page)

Diff. pressure $\Delta P^{(1)}$ (psi)	Effective area (sq. in.)					Diff. pressure $\Delta P^{(1)}$ (psi)	Effective area (sq. in.)				
	0.074	0.110	0.196	0.307	0.503		0.074	0.110	0.196	0.307	0.503
5	4.7	6.9				420	43.5	64.0	113	178	292
10	6.7	9.8	17.4			440	44.5	65.5	115	183	299
15	8.2	12.1	21.3	33.8	55.2	460	45.5	67.0	118	187	305
20	9.4	13.9	24.7	39.0	63.7	480	46.5	68.5	121	191	312
30	11.6	17.1	30.2	47.8	78.1	500	47.4	69.9	123	195	318
40	13.4	19.7	34.9	55.2	90.2	520	48.4	71.3	125	199	325
50	15.0	22.1	39.0	61.7	100	540	49.3	72.6	128	202	331
60	16.4	24.2	42.7	67.6	110	560	50.2	73.9	130	206	337
80	18.9	27.9	49.4	78.0	127	580	51.1	75.3	133	210	343
100	21.2	31.2	55.2	87.2	142	600	52.0	76.5	135	213	349
120	23.2	34.2	60.5	95.6	156	620	52.8	77.8	137	217	355
140	25.1	36.9	65.3	103	168	640	53.7	79.1	139	220	360
160	26.8	39.5	69.8	110	180	660	54.5	80.3	141	224	366
180	28.4	41.9	74.1	117	191	680	55.3	81.5	144	227	371
200	30.0	44.2	78.1	123	201	700	56.1	82.7	146	230	377
220	31.5	46.3	81.9	129	211	720	56.9	83.9	148	234	382
240	32.9	48.4	85.5	135	220	740	57.7	85.0	150	237	387
260	34.2	50.4	89.0	140	229	760	58.5	86.2	152	240	393
280	35.5	52.3	92.4	146	238	780	59.3	87.3	154	243	398
300	36.7	54.1	95.6	151	247	800	60.0	88.4	156	246	403
320	37.9	55.9	98.8	156	255	820	60.8	89.5	158	249	408
340	39.1	57.6	101	160	262	840	61.5	90.6	160	253	413
360	40.3	59.3	104	165	270	860	62.2	91.7	162	256	418
380	41.4	60.9	107	170	278	880	63.0	92.7	163	258	423
400	42.4	62.5	110	174	285	900	63.7	93.8	165	261	427

#### NOTES

1. Differential pressure ( $\Delta P$ ) equals inlet pressure (set pressure plus overpressure) at flowing conditions minus back pressure.
2. See pages 15-18 for minimum and maximum set pressure limits.
3. The scope of the ASME Code, Section VIII, does not include pressures below 15 psig and therefore pressure relief valves set below 15 psig are not stamped with the ASME Code Symbol.

**Capacity in U.S. gallons per minute of water at 70°F and 10% overpressure.**

Capacities certified by the National Board of Boiler and Pressure Vessel Inspectors and in accordance with the ASME Boiler and Pressure Vessel Code, Section VIII.

**CROSBY OMNI-TRIM®**  
**WATER CAPACITIES**

**WATER CAPACITIES - DIFFERENTIAL PRESSURES  $\Delta P^{(1)}$  5-5000 psi<sup>(2)</sup> (continued)**

Diff. pressure $\Delta P^{(1)}$ (psi)	Effective area (sq. in.)					Diff. pressure $\Delta P^{(1)}$ (psi)	Effective area (sq. in.)				
	0.074	0.110	0.196	0.307	0.503		0.074	0.110	0.196	0.307	0.503
920	64.4	94.8	167	264	432	3100	118	174			
940	65.1	95.8	169	267	437	3200	120	176			
960	65.8	96.8	171	270	441	3300	122	179			
980	66.4	97.8	172	273	446	3400	123	182			
1000	67.1	98.8	174	276	451	3500	125	184			
1100	70.4	103	183	289	473	3600	127	187			
1200	73.5	108	191	302	494	3700	129	190			
1300	76.5	112	199	314	514	3800	130	192			
1400	79.4	116	206	326	533	3900	132	195			
1500	82.2	121	213	338	552	4000	134	197			
1600	84.9	125	220	349	570	4100	136	200			
1700	87.5	128	227			4200	137	202			
1800	90.1	132	234			4300	139	205			
1900	92.5	136	240			4400	140	207			
2000	94.9	139	247			4500	142	209			
2100	97.3	143	253			4600	144	212			
2200	99.6	146	259			4700	145	214			
2300	101	149	264			4800	147	216			
2400	104	153	270			4900	148	218			
2500	106	156	276			5000	150	221			
2600	108	159	281								
2700	110	162	287								
2800	112	165									
2900	114	168									
3000	116	171									

**NOTES**

1. Differential pressure ( $\Delta P$ ) equals inlet pressure (set pressure plus overpressure) at flowing conditions minus back pressure. Capacity in U.S. gallons per minute of water at 70°F and 10% overpressure.



# CROSBY OMNI-TRIM®

## AIR CAPACITIES

SERIES 900 VALVES - METRIC UNITS

### AIR CAPACITIES - SET PRESSURES 0.35-338 barg (continued next page)

Set press. (barg)	Effective area (sq. mm.)					Set press. (kPag)	Set press. (barg)	Effective area (sq. mm.)					Set press. (kPag)
	47.7	71	126	198	325			47.7	71	126	198	325	
1 bar incr. <sup>(1)</sup>	0.5	0.8	1.5	2.4	4.0	100 kPa incr.	1 bar incr. <sup>(1)</sup>	0.5	0.8	1.5	2.4	4.0	100 kPa incr.
5 bar incr.	2.9	4.4	7.9	12.3	20.3	500 kPa incr.	5 bar incr.	2.9	4.4	7.9	12.3	20.3	500 kPa incr.
0.35	0.98	1.45	2.57			35	22	14.2	21.0	37.1	58.7	95.9	2200
0.4	1.01	1.50	2.65	4.19		40	24	15.5	22.8	40.3	63.8	104	2400
0.45	1.05	1.54	2.73	4.32		45	26	16.7	24.6	43.6	68.9	112	2600
0.5	1.08	1.59	2.81	4.45	7.27	50	28	18.0	26.5	46.8	74.0	121	2800
0.55	1.11	1.64	2.89	4.58	7.48	55	30	19.2	28.3	50.1	79.1	129	3000
0.6	1.14	1.68	2.98	4.70	7.69	60	32	20.5	30.2	53.3	84.3	137	3200
0.65	1.17	1.73	3.06	4.83	7.90	65	34	21.7	32.0	56.6	89.4	146	3400
0.7	1.20	1.77	3.14	4.96	8.11	70	36	23.0	33.8	59.8	94.5	154	3600
0.75	1.24	1.82	3.22	5.09	8.32	75	38	24.2	35.7	63.0	99.6	162	3800
0.8	1.27	1.87	3.30	5.22	8.53	80	40	25.5	37.5	66.3	104	171	4000
0.85	1.30	1.91	3.38	5.35	8.75	85	42	26.7	39.3	69.5	109	179	4200
0.9	1.33	1.96	3.47	5.48	8.96	90	44	27.9	41.2	72.8	115	187	4400
0.95	1.36	2.01	3.55	5.61	9.17	95	46	29.2	43.0	76.0	120	196	4600
1	1.39	2.05	3.63	5.74	9.38	100	48	30.4	44.8	79.2	125	204	4800
2	1.80	2.60	4.70	7.40	12.2	200	50	31.7	46.7	82.5	130	213	5000
4	3.00	4.50	7.90	12.6	20.5	400	52	32.9	48.5	85.7	135	221	5200
6	4.30	6.30	11.2	17.7	28.9	600	54	34.2	50.3	89.0	140	229	5400
8	5.50	8.10	14.4	22.8	37.3	800	56	35.4	52.2	92.2	145	238	5600
10	6.80	10.0	17.7	27.9	45.6	1000	58	36.7	54.0	95.5	150	246	5800
12	8.00	11.8	20.9	33.0	54.0	1200	60	37.9	55.8	98.7	156	254	6000
14	9.20	13.6	24.1	38.2	62.4	1400	62	39.2	57.7	101	161	263	6200
16	10.5	15.5	27.4	43.3	70.8	1600	64	40.4	59.5	105	166	271	6400
18	11.7	17.3	30.6	48.4	79.1	1800	66	41.7	61.3	108	171	280	6600
20	13.0	19.1	33.9	53.5	87.5	2000	68	42.9	63.2	111	176	288	6800

#### NOTES

1. Not valid below 2.0 barg set pressure.
2. Capacities below 2.0 barg set pressure are calculated at 0.2 bar overpressure.
3. The scope of the ASME Code, Section VIII, does not include pressures below 1.0 barg and therefore pressure relief valves set below 1.0 barg are not stamped with the ASME Code Symbol.

#### Capacity in standard cubic meters of air per minute at 16°C and 10% overpressure. Valve discharging to atmospheric pressure.<sup>(2)</sup>

Capacities certified by the National Board of Boiler and Pressure Vessel Inspectors and in accordance with the ASME Boiler and Pressure Vessel Code, Section VIII.

# CROSBY OMNI-TRIM®

## AIR CAPACITIES

### AIR CAPACITIES - SET PRESSURES 0.35-338 barg (continued)

Set press. (barg)	Effective area (sq. mm.)					Set press. (kPag)	Set press. (barg)	Effective area (sq. mm.)					Set press. (kPag)
	47.7	71	126	198	325			47.7	71	126	198	325	
1 bar incr. <sup>(1)</sup>	0.5	0.8	1.5	2.4	4.0	100 kPa incr.	1 bar incr. <sup>(1)</sup>	0.5	0.8	1.5	2.4	4.0	100 kPa incr.
5 bar incr.	2.9	4.4	7.9	12.3	20.3	500 kPa incr.	5 bar incr.	2.9	4.4	7.9	12.3	20.3	500 kPa incr.
70	44.1					7000	208	130	191				20800
76	47.9					7600	214	133	197				21400
82	51.6					8200	220	137	202				22000
88	55.4					8800	226	141	208				22600
94	59.1					9400	232	145	213				23200
100	62.8					10000	238	148	219				23800
106	66.6	98.0	173			10600	244	152	224				24400
112	70.3	103	183			11200	250	156	230				25000
118	74.1	109	192			11800	256	160	235				25600
124	77.8	114	202			12400	262	163	241				26200
130	81.5	120	212			13000	268	167	246				26800
136	85.3	125	221			13600	274	171	252				27400
142	89.0	131	231			14200	280	175	257				28000
148	92.8	136	241			14800	286	178	263				28600
154	96.5	142	251			15400	292	182	268				29200
160	100	147	260			16000	298	186	274				29800
166	104	153	270			16600	304	190	279				30400
172	107	158	280			17200	310	193	285				31000
178	111	164				17800	316	197	290				31600
184	115	169				18400	322	201	296				32200
190	118	175				19000	328	204	301				32800
196	122	180				19600	334	208	307				33400
202	126	186				20200	338	211	310				33800

#### NOTES

Capacity in standard cubic meters of air per minute at 16°C and 10% overpressure. Valve discharging to atmospheric pressure.<sup>(2)</sup>

# CROSBY OMNI-TRIM®

## SATURATED STEAM CAPACITIES

UNFIRED PRESSURE VESSEL SERVICE SERIES 900 VALVES - METRIC UNITS

### SATURATED STEAM CAPACITIES - SET PRESSURES 0.35-68 barg

Set pressure (barg)	Effective area (sq. mm.)					Set pressure (kPag)	Set pressure (barg)	Effective area (sq. mm.)					Set pressure (kPag)
	47.7	71.0	126	198	325			47.7	71.0	126	198	325	
0.1 bar incr. <sup>(1)</sup>	2.7	4.0	7.1	11.3	18.5	10 kPa incr.	0.1 bar incr.	2.7	4.0	7.1	11.3	18.5	10 kPa incr.
0.5 bar incr.	13.8	20.3	35.9	56.7	92.7	50 kPa incr.	0.5 bar incr.	13.8	20.3	35.9	56.7	92.7	50 kPa incr.
0.35	43.8	64.4				35	24	688	1013	1790	2828	4621	2400
0.4	45.2	66.5	117			40	25	715	1053	1862	2942	4807	2500
0.45	46.5	68.6	121			45	26	743	1094	1934	3055	4992	2600
0.5	47.9	70.6	124	197	322	50	27	771	1135	2005	3169	5178	2700
0.55	49.3	72.7	128	202	331	55	28	798	1175	2077	3282	5363	2800
0.6	50.7	74.7	132	208	341	60	29	826	1216	2149	3396	5549	2900
0.65	52.1	76.8	135	214	350	65	30	854	1257	2221	3510	5734	3000
0.7	53.5	78.8	139	220	359	70	31	881	1297	2293	3623	5919	3100
0.75	54.9	80.9	142	225	369	75	32	909	1338	2365	3737	6105	3200
0.8	56.3	82.9	146	231	378	80	33	936	1379	2436	3850	6290	3300
0.85	57.7	85.0	150	237	387	85	34	964	1419	2508	3964	6476	3400
0.9	59.1	87.0	153	243	397	90	35	992	1460	2580	4077	6661	3500
0.95	60.5	89.1	157	248	406	95	36	1019	1501	2652	4191	6847	3600
1	61.9	91.1	161	254	415	100	37	1047	1541	2724	4304	7032	3700
1.5	68.3	100	177	280	458	150	38	1074	1582	2796	4418	7218	3800
2	80.6	118	209	331	541	200	39	1102	1623	2868	4531	7403	3900
3	108	159	281	445	727	300	40	1130	1663	2939	4645	7589	4000
4	135	200	353	558	912	400	41	1157	1704	3011	4758	7774	4100
5	163	240	425	672	1098	500	42	1185	1745	3083	4872	7959	4200
6	191	281	497	785	1283	600	43	1213	1785	3155	4985	8145	4300
7	218	322	569	899	1469	700	44	1240	1826	3227	5099	8330	4400
8	246	362	640	1012	1654	800	45	1268	1867	3299	5212	8516	4500
9	274	403	712	1126	1839	900	46	1295	1907	3370	5326	8701	4600
10	301	444	784	1239	2025	1000	47	1323	1948	3442	5439	8887	4700
11	329	484	856	1353	2210	1100	48	1351	1989	3514	5553	9072	4800
12	356	525	928	1466	2396	1200	49	1378	2029	3586	5666	9258	4900
13	384	566	1000	1580	2581	1300	50	1406	2070	3658	5780	9443	5000
14	412	606	1071	1693	2767	1400	52	1461	2151	3801	6007	9814	5200
15	439	647	1143	1807	2952	1500	54	1516	2233	3945	6234	10185	5400
16	467	688	1215	1920	3138	1600	56	1572	2314	4089	6461	10556	5600
17	494	728	1287	2034	3323	1700	58	1627	2395	4232	6688	10927	5800
18	522	769	1359	2147	3509	1800	60	1682	2477	4376	6915	11298	6000
19	550	810	1431	2261	3694	1900	62	1737	2558	4520	7142	11669	6200
20	577	850	1503	2374	3879	2000	64	1793	2639	4664	7369	12039	6400
21	605	891	1574	2488	4065	2100	66	1848	2721	4807	7596	12410	6600
22	633	931	1646	2601	4250	2200	68	1903	2802	4951	7823	12781	6800
23	660	972	1718	2715	4436	2300							

#### NOTES

1. Not valid below 2.0 barg set pressure.
2. Capacities below 2.0 barg set pressure are calculated at 0.2 bar overpressure.
3. Maximum set pressure for steam service is 68.95 barg.
4. The scope of the ASME Code, Section VIII, does not include pressures below 1.0 barg and therefore pressure relief valves set below 1.0 barg are not stamped with the ASME Code Symbol.

#### Capacity in kilograms per hour of steam at 10% overpressure. Valve discharging to atmospheric pressure.<sup>(2)</sup>

Capacities certified by the National Board of Boiler and Pressure Vessel Inspectors and in accordance with the ASME Boiler and Pressure Vessel Code, Section VIII.

# CROSBY OMNI-TRIM®

## WATER CAPACITIES

SERIES 900 OMNI-TRIM® VALVES - METRIC UNITS

### WATER CAPACITIES - DIFFERENTIAL PRESSURES $\Delta P^{(1)}$ 0.4-380 bar<sup>(2)</sup> (continued next page)

Diff. pressure $\Delta P^{(1)}$ (bar)	Effective area (sq. mm)					Diff. pressure $\Delta P^{(1)}$ (kPa)	Diff. pressure $\Delta P^{(1)}$ (bar)	Effective area (sq. mm)					Diff. pressure $\Delta P^{(1)}$ (kPa)
	47.7	71	126	198	325			47.7	71	126	198	325	
0.4	19.3	28.5	50.3			40	40	193	285	503	795	1300	4000
0.6	23.7	34.9	61.6	97.4	159	60	42	198	292	516	815	1332	4200
0.8	27.3	40.3	71.2	112	183	80	44	203	299	528	834	1363	4400
1	30.6	45.0	79.6	125	205	100	46	207	305	540	853	1394	4600
2	43.3	63.7	112	177	290	200	48	212	312	551	871	1424	4800
4	61.2	90.1	159	251	411	400	50	216	318	563	889	1453	5000
6	75.0	110	195	308	503	600	52	220	325	574	907	1482	5200
8	86.6	127	225	355	581	800	54	225	331	585	924	1510	5400
10	96.8	142	251	397	650	1000	56	229	337	596	941	1538	5600
12	106	156	275	435	712	1200	58	233	343	606	958	1565	5800
14	114	168	298	470	769	1400	60	237	349	616	974	1592	6000
16	122	180	318	503	822	1600	62	241	354	627	990	1618	6200
18	129	191	337	533	872	1800	64	244	360	637	1006	1644	6400
20	136	201	356	562	919	2000	66	248	366	647	1022	1670	6600
22	143	211	373	590	964	2200	68	252	371	656	1037	1695	6800
24	150	220	390	616	1007	2400	70	256	377	666	1052	1720	7000
26	156	229	406	641	1048	2600	76	266	392	694	1097	1792	7600
28	162	238	421	665	1087	2800	82	277	408	721	1139	1861	8200
30	167	246	436	689	1126	3000	88	287	422	747	1180	1928	8800
32	173	255	450	711	1163	3200	94	296	437	772	1220	1993	9400
34	178	262	464	733	1198	3400	100	306	450	796	1258	2056	10000
36	183	270	477	755	1233	3600	106	315	464	820	1295	2116	10600
38	188	277	490	775	1267	3800	112	324	477	842	1331	2175	11200

#### NOTES

1. Differential pressure ( $\Delta P$ ) equals inlet pressure (set pressure plus overpressure) at flowing conditions minus back pressure.
2. See pages 19-22 for minimum and maximum set pressure limits.
3. The scope of the ASME Code, Section VIII, does not include pressures below 1.0 barg and therefore pressure relief valves set below 1.0 barg are not stamped with the ASME Code Symbol.

#### Capacity in liters per minute of water at 20°C and 10% overpressure.

Capacities certified by the National Board of Boiler and Pressure Vessel Inspectors and in accordance with the ASME Boiler and Pressure Vessel Code, Section VIII.

# CROSBY OMNI-TRIM®

## WATER CAPACITIES

### WATER CAPACITIES - DIFFERENTIAL PRESSURES $\Delta P^{(1)}$ 0.4-380 bar<sup>(2)</sup> (continued)

Diff. pressure $\Delta P^{(1)}$ (bar)	Effective area (sq. mm)					Diff. pressure $\Delta P^{(1)}$ (kPa)	Diff. pressure $\Delta P^{(1)}$ (bar)	Effective area (sq. mm)					Diff. pressure $\Delta P^{(1)}$ (kPa)
	47.7	71	126	198	325			47.7	71	126	198	325	
118	332	489	865	1367	2233	11800	256	489	721				25600
124	340	501	886	1401	2289	12400	262	495	729				26200
130	349	513	908			13000	268	501	737				26800
136	357	525	928			13600	274	506	746				27400
142	364	537	949			14200	280	512	754				28000
148	372	548	968			14800	286	517	762				28600
154	379	559	988			15400	292	523	770				29200
160	387	570	1007			16000	298	528	778				29800
166	394	580	1026			16600	304	533	785				30400
172	401	591	1044			17200	310	539	793				31000
178	408	601	1062			17800	316	544	801				31600
184	415	611	1080			18400	322	549	808				32200
190	422	621				19000	328	554	816				32800
196	428	631				19600	334	559	823				33400
202	435	640				20200	340	564	831				34000
208	441	650				20800	346	569	838				34600
214	447	659				21400	352	574	845				35200
220	454	668				22000	358	579	852				35800
226	460	677				22600	364	584	860				36400
232	466	686				23200	370	588	867				37000
238	472	695				23800	376	593	874				37600
244	478	704				24400	380	596	878				38000
250	484	712				25000							

#### NOTES

1. Differential pressure ( $\Delta P$ ) equals inlet pressure (set pressure plus overpressure) at flowing conditions minus back pressure.
2. See pages 19-22 for minimum and maximum set pressure limits.
3. The scope of the ASME Code, Section VIII, does not include pressures below 1.0 barg and therefore pressure relief valves set below 1.0 barg are not stamped with the ASME Code Symbol.

#### Capacity in liters per minute of water at 20°C and 10% overpressure.

Capacities certified by the National Board of Boiler and Pressure Vessel Inspectors and in accordance with the ASME Boiler and Pressure Vessel Code, Section VIII.

# CROSBY OMNI-TRIM®

## AIR CAPACITIES

SERIES BP, USCS UNITS (U.S. CUSTOMARY SYSTEM)

### USCS - SET PRESSURES 50-1500 psig

Set pressure (psig)	Effective area (sq. in.)		Set pressure (psig)	Effective area (sq. in.)	
	0.074	0.110		0.074	0.110
1 psi incr.	1.5	2.3	1 psi incr.	1.5	2.3
5 psi incr.	7.8	11.5	5 psi incr.	7.8	11.5
50	99	146	560	903	1326
60	115	169	580	934	1372
70	131	192	600	966	1418
80	147	215	620	997	1465
90	162	239	640	1029	1511
100	178	262	660	1060	1557
120	210	308	680	1092	1603
140	241	354	700	1123	1650
160	273	401	720	1155	1696
180	304	447	740	1186	1742
200	336	493	760	1218	1788
220	367	539	780	1249	1835
240	399	586	800	1281	1881
260	430	632	820	1312	1927
280	462	678	840	1344	1973
300	493	724	860	1375	2020
320	525	771	880	1407	2066
340	556	817	900	1438	2112
360	588	863	920	1470	2158
380	619	909	940	1501	2205
400	651	956	960	1533	2251
420	682	1002	980	1564	2297
440	714	1048	1000	1596	2343
460	745	1094	1100	1753	2575
480	777	1141	1200	1911	2806
500	808	1187	1300	2069	3037
520	840	1233	1400	2226	3269
540	871	1279	1500	2384	3500

#### NOTE

- To determine capacities on gases other than air, or for fluid temperatures other than 60°F (16°C), use the gas and vapor sizing formula in the Crosby Engineering Handbook.

#### Note: for air capacities, USCS units are exact equivalents of imperial units.

The capacities listed in the table above are based on discharging to atmospheric pressure. For applications involving back pressure these capacities must be multiplied by the back pressure correction factor determined from the applicable curve shown on page 40.

#### Capacity in standard cubic feet per minute of air at 60°F and 10% overpressure. Valve discharging to atmospheric pressure. (Capacity in standard cubic meters of air per minute at 16°C and 10% overpressure. Valve discharging to atmospheric pressure.)

Capacities certified by the National Board of Boiler and Pressure Vessel Inspectors and in accordance with the ASME Boiler and Pressure Vessel Code, Section VIII.

# CROSBY OMNI-TRIM®

## WATER CAPACITIES

SERIES BP, USCS UNITS (U.S. CUSTOMARY SYSTEM)

### USCS - DIFFERENTIAL PRESSURES $\Delta P^{(1)}$ 20-1600 psi

Diff. pressure $\Delta P$ (psi)	Effective area (sq. in.)		Diff. pressure $\Delta P$ (psi)	Effective area (sq. in.)	
	0.074	0.110		0.074	0.110
50	15.7	23.1	580	53.6	78.7
60	17.2	25.3	600	54.5	80.1
80	19.9	29.2	620	55.4	81.4
100	22.2	32.7	640	56.3	82.7
120	24.4	35.8	660	57.2	84.0
140	26.3	38.6	680	58.0	85.2
160	28.1	41.3	700	58.9	86.5
180	29.8	43.8	720	59.7	87.7
200	31.5	46.2	740	60.5	88.9
220	33.0	48.5	760	61.4	90.1
240	34.5	50.6	780	62.2	91.3
260	35.9	52.7	800	63.0	92.5
280	37.2	54.7	820	63.7	93.6
300	38.5	56.6	840	64.5	94.7
320	39.8	58.5	860	65.3	95.9
340	41.0	60.3	880	66.0	97.0
360	42.2	62.0	900	66.8	98.1
380	43.4	63.7	920	67.5	99.1
400	44.5	65.4	940	68.2	100
420	45.6	67.0	960	69.0	101
440	46.7	68.6	980	69.7	102
460	47.7	70.1	1000	70.4	103
480	48.8	71.6	1100	73.8	108
500	49.8	73.1	1200	77.1	113
520	50.7	74.5	1300	80.3	117
540	51.7	75.9	1400	83.3	122
560	52.7	77.3	1500	86.2	126

#### NOTES

1. Differential pressure ( $\Delta P$ ) equals inlet pressure (set pressure plus overpressure) at flowing conditions minus back pressure.
2. See pages 23 and 24 for minimum and maximum set pressure limits.

**Note: USCS units for water and liquids are U.S. gallons per minute (1 U.S. gallon equals 0.833 imperial gallon).**

The capacities listed in the table above are based on discharging to atmospheric pressure. For applications involving back pressure these capacities must be multiplied by the back pressure correction factor determined from the applicable curve shown on page 40.

**Capacity in U.S. gallons per minute of water at 70°F and 10% overpressure. Capacities certified by the National Board of Boiler and Pressure Vessel Inspectors and in accordance with the ASME Boiler and Pressure Vessel Code, Section VIII. (Capacity in liters per minute of water at 21°C and 10% overpressure.)**

Capacities certified by the National Board of Boiler and Pressure Vessel Inspectors and in accordance with the ASME Boiler and Pressure Vessel Code, Section VIII.

# CROSBY OMNI-TRIM®

## AIR CAPACITIES

SERIES BP, USCS UNITS (METRIC UNITS)

### METRIC - SET PRESSURES 3.45-103 barg

Set pressure (barg)	Effective area (sq. mm)		Set pressure (kPag)	Set pressure (barg)	Effective area (sq. mm)		Set pressure (kPag)
	47.74	70.96			47.74	70.96	
1 bar incr.	1.26	1.85	100 kPa incr.	1 bar incr.	1.26	1.85	100 kPa incr.
5 bar incr.	3.89	5.71	500 kPa incr.	5 bar incr.	3.89	5.71	500 kPa incr.
3.45	2.87	4.21	345	44	29.5	43.3	4400
4	3.23	4.74	400	46	30.8	45.2	4600
6	4.54	6.67	600	48	32.1	47.1	4800
8	5.86	8.60	800	50	33.4	49.1	5000
10	7.17	10.50	1000	52	34.7	51.0	5200
12	8.48	12.40	1200	54	36.0	52.9	5400
14	9.80	14.30	1400	56	37.3	54.9	5600
16	11.10	16.30	1600	58	38.7	56.8	5800
18	12.40	18.20	1800	60	40.0	58.7	6000
20	13.70	20.10	2000	62	41.3	60.6	6200
22	15.00	22.10	2200	64	42.6	62.6	6400
24	16.30	24.00	2400	66	43.9	64.5	6600
26	17.60	25.90	2600	68	45.2	66.4	6800
28	19.00	27.80	2800	70	46.5	68.4	7000
30	20.30	29.80	3000	76	50.5	74.1	7600
32	21.60	31.70	3200	82	54.4	79.9	8200
34	22.90	33.60	3400	88	58.4	85.7	8800
36	24.20	35.60	3600	94	62.3	91.5	9400
38	25.50	37.50	3800	100	66.3	97.3	10000
40	26.80	39.40	4000	103	68.2	100.0	10300
42	28.10	41.40	4200				

#### NOTE

- To determine capacities on gases other than air, or for fluid temperatures other than 60°F (16°C), use the gas and vapor sizing formula in the Crosby Engineering Handbook.

#### Note: for air capacities, USCS units are exact equivalents of imperial units.

The capacities listed in the table above are based on discharging to atmospheric pressure. For applications involving back pressure these capacities must be multiplied by the back pressure correction factor determined from the applicable curve shown on page 40.

#### Capacity in standard cubic feet per minute of air at 60°F and 10% overpressure.

**Valve discharging to atmospheric pressure. (Capacity in standard cubic meters of air per minute at 16°C and 10% overpressure. Valve discharging to atmospheric pressure.)**

Capacities certified by the National Board of Boiler and Pressure Vessel Inspectors and in accordance with the ASME Boiler and Pressure Vessel Code, Section VIII.



# CROSBY OMNI-TRIM®

## WATER CAPACITIES

SERIES BP (METRIC UNITS)

### METRIC - SET PRESSURES 3.45-103 barg

Diff. pressure $\Delta P$ (barg)	Effective area (sq. mm)		Diff. pressure $\Delta P$ (kPa)	Diff. pressure $\Delta P$ (barg)	Effective area (sq. mm)		Diff. pressure $\Delta P$ (kPa)
	47.74	70.96			47.74	70.96	
1.4	37.9	55.7	140	44	213	312	4400
2	45.4	66.6	200	46	217	319	4600
4	64.2	94.2	400	48	222	326	4800
6	78.6	115	600	50	227	333	5000
8	90.8	133	800	52	231	339	5200
10	101	149	1000	54	235	346	5400
12	111	163	1200	56	240	352	5600
14	120	176	1400	58	244	359	5800
16	128	188	1600	60	248	365	6000
18	136	200	1800	62	252	371	6200
20	143	210	2000	64	256	377	6400
22	150	221	2200	66	260	383	6600
24	157	230	2400	68	264	388	6800
26	163	240	2600	70	268	394	7000
28	169	249	2800	76	279	411	7600
30	175	258	3000	82	290	426	8200
32	181	266	3200	88	301	442	8800
34	187	274	3400	94	311	457	9400
36	192	282	3600	100	321	471	10000
38	197	290	3800	106	330	485	10600
40	203	298	4000	112	339	498	11200
42	208	305	4200				

#### NOTES

1. Differential pressure ( $\Delta P$ ) equals inlet pressure (set pressure plus overpressure) at flowing conditions minus back pressure.
2. See pages 23 and 24 for minimum and maximum set pressure limits.

**Note: USCS units for water and liquids are U.S. gallons per minute (1 U.S. gallon equals 0.833 imperial gallon).**

The capacities listed in the table above are based on discharging to atmospheric pressure. For applications involving back pressure these capacities must be multiplied by the back pressure correction factor determined from the applicable curve shown on page 40.

**Capacity in U.S. gallons per minute of water at 70°F and 10% overpressure. Capacities certified by the National Board of Boiler and Pressure Vessel Inspectors and in accordance with the ASME Boiler and Pressure Vessel Code, Section VIII. (Capacity in liters per minute of water at 21°C and 10% overpressure.)**

Capacities certified by the National Board of Boiler and Pressure Vessel Inspectors and in accordance with the ASME Boiler and Pressure Vessel Code, Section VIII.

# CROSBY OMNI-TRIM®

## BACK PRESSURE CORRECTION FACTORS

BACK PRESSURE FLOW CORRECTION FACTOR CURVES (SERIES BP OMNI-TRIM®)

**Correction factor for liquids,  
K<sub>w</sub> for Series BP valves at 10% overpressure**

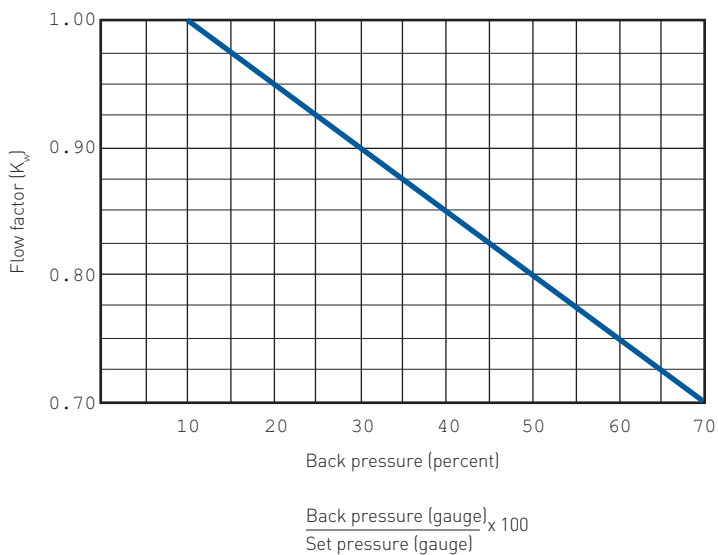

**Correction factor for vapors and gases,  
K<sub>b</sub> for Series BP valves at 10% overpressure**

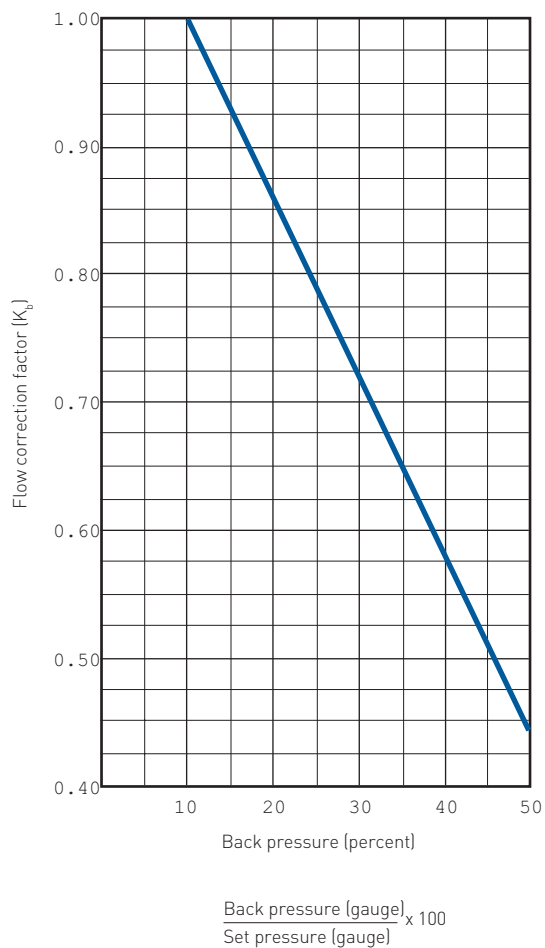

# CROSBY OMNI-TRIM®

## ORDERING INFORMATION - MODEL NUMBERING

### SERIES 900 AND BP

Example	9	5	1	3	2	1
<b>Series</b>						
<b>9</b> Series 900 fixed blowdown relief valve						
<b>BP</b> Back pressure balanced threaded relief valve						
<b>Effective orifice area<sup>(5)</sup></b>						
<b>5</b> 0.074 in <sup>2</sup> (47.74 mm <sup>2</sup> ) - Series 900 and BP only						
<b>6</b> 0.110 in <sup>2</sup> (71.0 mm <sup>2</sup> )						
<b>7</b> 0.196 in <sup>2</sup> (126 mm <sup>2</sup> ) - Series 900 only						
<b>8</b> 0.307 in <sup>2</sup> (198 mm <sup>2</sup> ) - Series 900 only						
<b>9</b> 0.503 in <sup>2</sup> (325 mm <sup>2</sup> ) - Series 900 only						
<b>Maximum set pressure<sup>(1,2)</sup></b>						
<b>1</b> 1500 psig (103.42 barg)						
<b>2</b> 2500 psig (172.36 barg) - Series 900 only						
<b>5</b> 5000 psig (344.74 barg) - Series 900 only						
<b>Seat material<sup>(6)</sup></b>						
<b>1</b> Metal - Series 900 only						
<b>2</b> Buna-N						
<b>3</b> Viton® (FKM)						
<b>4</b> EPR						
<b>5</b> Kalrez®						
<b>6</b> TFE						
<b>A</b> Silicone						
<b>X</b> Other						
<b>Materials of construction<sup>(3,4)</sup></b>						
<b>0</b> Standard						
<b>1</b> All 316 SS						
<b>2</b> All 316 SS with Inconel® X750 spring						
<b>3</b> CS cylinder Monel® base/disc/disc holder/guide, Inconel® X750 spring						
<b>4</b> All Monel® with Inconel® X750 spring						
<b>5</b> CS cylinder, Hastelloy® C base/disc/disc holder/guide, Inconel® X750 spring (900 and BP only)						
<b>6</b> All Hastelloy® C (900 and BP only)						
<b>7</b> Standard, 316 SS internals, Inconel® X750 spring						
<b>X</b> Other						
<b>Inlet x outlet connection size (NPS)</b>						
<b>0</b> ½ x 1 - Series 900 only						
<b>1</b> ¾ x 1						
<b>2</b> 1 x 1						
<b>3</b> 1 x 1½ - Series 900 only						
<b>4</b> 1½ x 1½ - Series 900 only						
<b>5</b> 1½ x 2 - Series 900 only						
<b>6</b> 2 x 2 - Series 900 only						
<b>7</b> 1½ x 2½ - Series 900 only						
<b>X</b> Other						

### NOTES

1. Maximum set pressure for steam service is 1000 psig (68.95 barg).
2. See pages 11-24 for appropriate maximum set pressures.
3. For steam service, a 17-4Ph disc holder is used.
4. See pages 4, 6 and 8 for complete listing of materials of construction.
5. See pages 11-24 for appropriate inlet and outlet sizes for each effective orifice area.
6. For Series BP, seat and seal materials are identical except for valves with TFE seats. Seal material for valves with TFE seats is Viton®(FKM) unless specified otherwise.

### CAUTION

Refer to pages 11-24 for availability of orifice, connection size, and connection type combination selected.

# CROSBY OMNI-TRIM®

## ORDERING INFORMATION - MODEL NUMBERING

### SERIES 900 AND BP (continued)

Example	32	T	E	-	PN2
<b>Inlet connection x outlet connection type</b>					
<b>MF</b>	MNPT x FNPT				
<b>FF</b>	FNPT x FNPT				
<b>11</b>	150# x 150#				
<b>21</b>	300# x 150#				
<b>22</b>	300# x 300#				
<b>31</b>	600# x 150#				
<b>32</b>	600# x 300#				
<b>42</b>	1500# x 300#				
<b>52</b>	2500# x 300# - Series 900 only				
<b>88</b>	MSW x MSW <sup>(1,2)</sup> - Series 900 only				
<b>99</b>	Bolted cylinder design (951 orifice only)				
<b>XX</b>	Other				
<b>Connection facing</b>					
<b>None</b>	NPT or SWE				
<b>None</b>	RF x RF				
<b>R</b>	RTJ X RF				
<b>T</b>	J x RTJ				
<b>X</b>	Other				
<b>Cap and lifting lever type</b>					
<b>A</b>	Standard threaded cap				
<b>B</b>	Threaded cap with test rod				
<b>D</b>	Packed lifting lever				
<b>E</b>	Packed lifting lever with test rod				
<b>X</b>	Other				
<b>Model number supplements indicator</b>					
<b>None</b>	No model number supplement(s)				
<b>-</b>	If model number supplement is present				
<b>Model number supplements<sup>(4)</sup></b>					
<b>P</b>	PED certification				
<b>N2</b>	ANSI/NACE MR0175/ISO 15156-1:2015 <sup>(3)</sup>				
<b>R</b>	TERV bolted cylinder				
<b>S</b>	Steam trim				
<b>B</b>	Forged block body configurations				
<b>SPL</b>	Non-standard option or configuration				
<b>L</b>	Lap Joint Inlet x Lap Joint Outlet (for 951, 955, 961, 965 & 972 models only)				

### AVAILABLE OPTIONS

#### Materials

- Special materials LCB, Alloy 20, Duplex, Titanium, etc.
- Special flange materials Monel®, Hastelloy® C, etc.
- Special O-ring seat materials.

#### Accessories

- Position indicator, proximity switch, etc.

#### Connections

- Weldneck flanges.
- Custom center-to-face dimensions.
- Special connections such as tri-clamp, GRAYLOC, etc.
- International flange standards.
- Flat face and RFSF flange options.

#### Others

- Special painting or coating.
- Special cleaning and testing.

### NOTES

1. Contact your sales representative for dimensions.
2. Not available with soft seats, contact your sales representative.
3. Contact your sales representative for specific compliance to NACE requirements.
4. More than one model number supplement can be used at once.  
Examples:  
951101MFA  
96137121A-N2  
965X1222D-N2-SPL

# CROSBY OMNI-TRIM®

## ORDERING INFORMATION - PARTS

---

### Parts

To order parts, the following information should be included:

1. Quantity
2. Part name, e.g., disc insert
3. Size, series and valve number
4. Shop number (from valve nameplate)
5. Serial number (from valve nameplate)
6. Original purchase order number (if shop number has been destroyed).

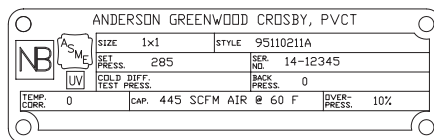

Sample nameplate  
(for illustrative purposes only)

Emerson provides special 'fast response' delivery service of spare parts to satisfy unplanned parts requirements which can be initiated by contacting your local representative. Emergency delivery service is available direct from the factory, 24 hours a day, 7 days a week.

### Springs with washers

To order springs with washers, in addition to the other information included for 'Parts', the required valve set pressure must also be specified. If the spring is for a non-bellows valve, and there is a constant back pressure condition, that should also be specified as should the spring material, if other than standard.

### Replacement valves

To replace a valve in service, the shop number, serial number, set pressure and previous order number should be specified.

# CROSBY OMNI-TRIM®

## SIZING AND SELECTION

---

### PRESSURE RELIEF DEVICE SIZING AND SELECTION SOFTWARE

---

Emerson PRV<sup>2</sup>SIZE incorporates over 135 years of experience and engineering expertise for an extensive array of Anderson Greenwood, Crosby and Varec pressure relief devices and related products in one software package. It enables you to address numerous applications in a single sizing and selection platform without the need to use two or more sizing programs.

#### Emerson PRV<sup>2</sup>SIZE features:

- User-friendly interface
  - Sizing calculations can be saved at any point
  - Multiple tags can be opened at one time
- Ability to sort data using a variety of parameters
- Fully configured product selection
- Industry standard sizing methodologies
- Drop-down boxes allow instantaneous change of sizing methodology from API to ASME and vice-versa
- 2:1 elliptical head tanks for fire sizing applications
- Catalog integration from existing product literature PDF's
- Detailed product specifications including cross sectional drawings with dimensions and weights
  - U.S. Customary System and metric units
- Advanced tools to export and import device tag numbers with the ability to mail files directly from the software program
- Combination device, reaction force and noise level calculations
- Flow curves for pressure and vacuum relief valves
- Individual capsule summaries of each product including an image of the selected product

Another unique feature of Emerson PRV<sup>2</sup>SIZE is its capability to provide sizing and selection for tank protection and tank blanketing products in a single software program. This includes pad and de-pad valves, tank blanketing regulators, pressure/vacuum vents and low pressure pilot operated relief valves.

Emerson PRV<sup>2</sup>SIZE website: [valvesizing.emerson.com](http://valvesizing.emerson.com)



**CROSBY** OMNI-TRIM®  
DIRECT SPRING PRESSURE RELIEF VALVES

---

VCTDS-00594-EN © 2015, 2021 Emerson Electric Co. All rights reserved 04/21. Crosby is a mark owned by one of the companies in the Emerson Automation Solutions business unit of Emerson Electric Co. The Emerson logo is a trademark and service mark of Emerson Electric Co. All other marks are the property of their prospective owners.

The contents of this publication are presented for informational purposes only, and while every effort has been made to ensure their accuracy, they are not to be construed as warranties or guarantees, express or implied, regarding the products or services described herein or their use or applicability. All sales are governed by our terms and conditions, which are available upon request. We reserve the right to modify or improve the designs or specifications of such products at any time without notice.

Emerson Electric Co. does not assume responsibility for the selection, use or maintenance of any product. Responsibility for proper selection, use and maintenance of any Emerson Electric Co. product remains solely with the purchaser.

Emerson.com