

# Product Information

## Servo-controlled solenoid valve NC, DN 10



### A.u.K. Müller

Solenoid valves  
Control valves  
Special valves and systems

A. u. K. Müller GmbH & Co. KG  
Dresdener Str. 162  
D-40595 Düsseldorf/Germany

Tel.: +49(0)211-7391-0  
Fax: +49(0)211-7391-281

e-mail: [info@akmueller.de](mailto:info@akmueller.de)  
Internet: [www.akmueller.de](http://www.akmueller.de)

### Series 01.010.315



### Characteristics

- ✓ Servo-controlled
- ✓ Normally closed (NC)
- ✓ Solenoid replaceable while medium circuit remains untouched, solenoid rotatable 4x90°
- ✓ Suitable for hot water up to 90 °C
- ✓ Similar performance for alternating or direct current
- ✓ Long term performance capability
- ✓ Optimized water hammer characteristic by low noise emission according to EN 60730
- ✓ High operating safety by the use of high quality materials and 100% final testing of the products

### Applications

- Steam appliances
- Dental appliances
- Hot / cold drink dispensers
- Industrial appliances
- Air conditioning
- Agricultural implements
- Pollution equipment
- Temperature equalisers
- Dish washers
- Ice machines
- Washing machines
- Water treatment

### Description

2/2-way solenoid valve of nominal diameter DN 10 for use with cold and heated potable water and physically and chemically similar media. The valve is servo-controlled and normally closed (NC).

Valves of this design are three-chamber valves with the inlet ninety degrees to the outlet and can be manufactured with various connections. Coil systems for common voltage and frequency ranges are available.

Electrical operating safety is achieved by insulation class F and can be supported by an integrated protective circuit.

By using high quality insulation materials, continuous duty (100 % ED) at higher medium temperatures is possible. The glass fibre reinforced polyamide valve body persists hot water. Protection against corrosion of inner parts exposed to the medium is achieved by using stainless steel.

### Possible approvals

Approved versions available on request:

- KTW/W270
- SVGW
- WRAS
- NSF 169
- VDE
- UL
- CSA
- Others on request

typical performance curve

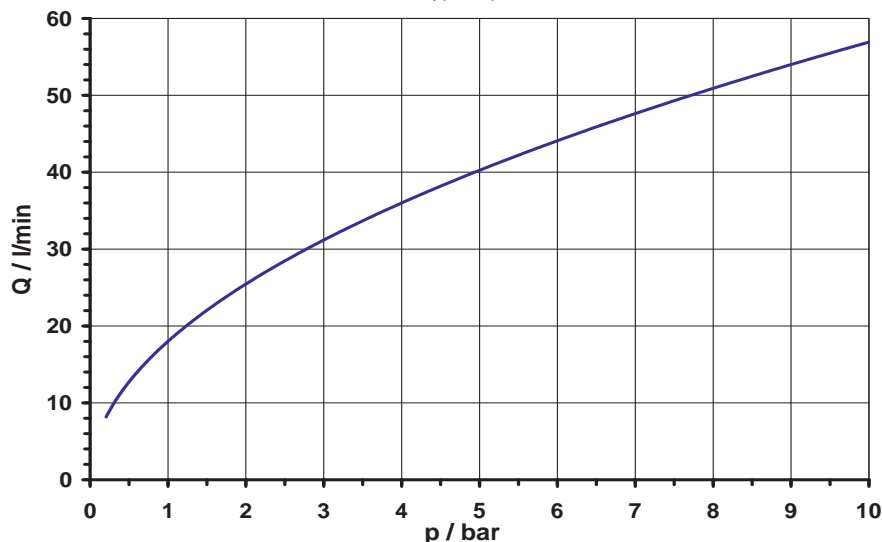



### Series 01.010.315

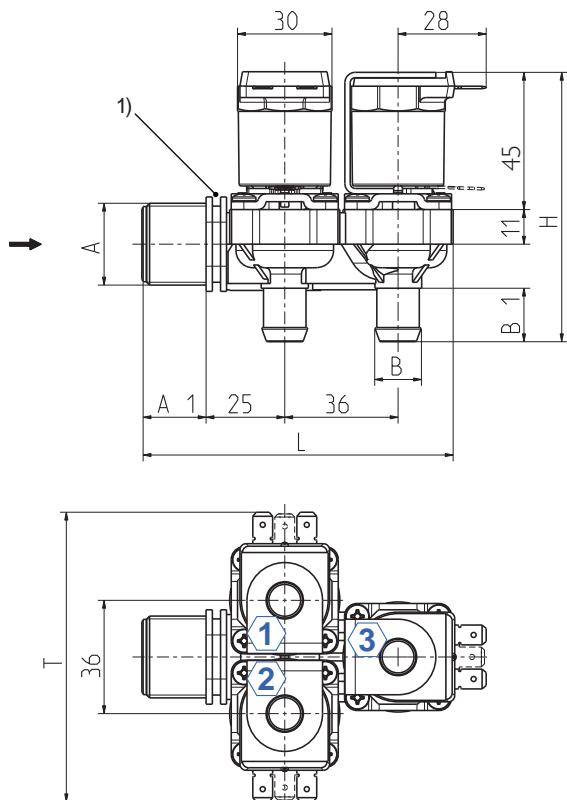

### Materials

<b>Valve body</b>	PA 66 glass fibre reinforced PPE on request PEI on request (T-medium max. 30 °C)
<b>Plunger guide</b>	stainless steel
<b>Plunger and spring</b>	stainless steel
<b>Membrane and sealings</b>	EPDM NBR (on request) VMQ (on request)
<b>Coil coating</b>	PBT, PET or epoxy resin
<b>Filter</b>	POM (in inlet) stainless steel on request

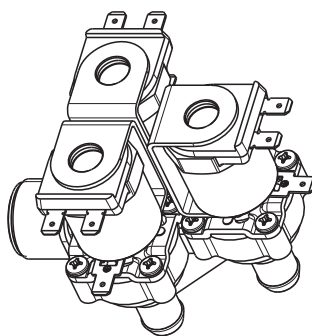

1) Fixing groove  
①, ②, ③ valve chamber

### Options

Material	Inlet		Outlet		Length L	Height H	Depth T
	Ø A	A1	Ø B	B1			
PA 66	G 3/4	20,0	3x 14,5 nozzle	17,0	100,0	85,0	92,0
PA 66	G 3/4	20,0	3x 14,5 nozzle with G 1/8 x 10 female	17,0	100,0	85,0	92,0
PA 66	G 3/4	20,0	3x 14,5 nozzle with M10 x 1 x 10 female	17,0	100,0	85,0	92,0
PA 66	G 3/4	20,0	3x G 1/4x12	17,0	100,0	85,0	92,0

### Technical Data

<b>Type</b>	solenoid valve	
<b>Construction</b>	2/2-way 3 chamber valve inlet ninety degree to outlet, servo-controlled	
<b>Function</b>	NC (normally closed)	
<b>Fitting position</b>	any, preferably with coil upwardly	
<b>Media</b>	cold and heated potable water and physically and chemically similar media	
<b>T-Medium</b>	90	°C max.
<b>T-Ambient</b>	70 (60)	°C max. °C max. USA and coils MS.024, MS.025)
<b>DN</b>	10	mm
<b>p-Operating</b>	0,2 - 10	bar
<b>Cv-value</b>	18	l/min
<b>Flow regulator</b>	on request	
<b>Pressure surge</b>	according to EN 60730	
<b>Coil type</b>	MS.006, MS.024, MS.025	
<b>Nominal voltages</b>	220 - 240 110 110 - 127 24 12 24 12	V AC 50-60 Hz V AC 50 Hz V AC 60 Hz V AC 50/60 Hz V AC 50/60 Hz V DC V DC
	other voltages on request	
<b>Voltage tolerance</b>	+10% -15%	
<b>Duty cycle</b>	100%	
<b>Nominal power</b>	8,5 W	13 VA (AC only)
<b>Protection type</b>	IP 00 up to IP 68	
<b>Coil connections</b>	flat tabs 6,3 x 0,8 mm plug socket according to EN 175301-803 (IP65), several cable connections (IP67, IP68)	
<b>Insulation class</b>	F	according to EN 60730
<b>Protection class</b>	I	according to EN 60730 (for incorporation in class I)

**MS.006**  
(IP00)



**MS.024**  
(IP65)



**MS.025**  
(IP67,  
IP68)

