

Delta Element Steam Traps

Models: M3A, GM3

CRN: Canadian Registration Number Available

FOR PROCESS AND HEATING SYSTEMS

3 Year No Live Steam Loss Guarantee

A series of steam traps designed for fast start-up and modulating discharge with no live steam loss.

- **Maximum differential pressure** - 30 psig / 2,1 bar
- **Single blade element** – offers long-term, trouble-free service because it's not prone to dirt build-up as encountered with many other bimetal designs
- **Stainless Steel internals** – leads to longer service life since materials are highly resistant to fatigue and corrosion
- **Modulating discharge** – automatically adjusts to operating pressure and load
- **Integral strainer and check valve** – strainer protects trap from dirt while check valve prevents backflow during shutdown
- **Continuous air and CO2 venting** – maximizes heat transfer while minimizing corrosion
- **Easy maintenance** – traps are in-line repairable when isolated from live steam system and can be up and running again in minutes

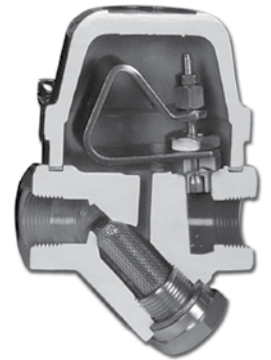

ORDERING SCHEMATIC

MODEL					6	7	8
M	0	0	3	A			

MODEL					6	7	8
G	M	0	0	3			

6	SIZE
1	3/8" (M3A)
2	1/2" (All)
3	3/4" (All)
4	1" (GM3)
5	1-1/4" (GM3)
6	1-1/2" (GM3)
7	2" (GM3)

7	CONNECTIONS
1	NPT
2	FSW*
3	150# Flange
4	300# Flange (2" GM3)
8	BSPT
9	BSPP

8	SPECIALS
0	None
1	DTC*
3	Integral Blowdown*

* Not available on 2" GM3



A Division of
 Richards Industries
 BEP Bestobell Ltd.
 2880 Argentia Rd.,
 Unit 3, Mississauga,
 ON, L5N 7X8

toll free. 800.668.3979
 local. 905.826.1953
 fax. 905.826.1778

salesdesk@bestobell.com
www.bestobell.com

FOR PROCESS AND HEATING SYSTEMS
SPECIFICATIONS (M3A & GM3 1/2" - 1-1/2" SIZES)

Maximum Differential Pressure: 30 psi (2,1 bar)

Maximum Allowable Pressure: 750 psig (51,7 bar)

Maximum Allowable Temperature: 750°F (399°C)

MATERIALS

Body & Cover: Forged Carbon Steel A105

Valve Seat: 303 SST & Stem: 17-4 SST

Bi-Metal: Stainless Steel NiCr

Strainer: Stainless Steel 304

Bolts: ASTM-A193, B7

Gasket: Flexible Graphite

Options: Double Threaded Strainer Cap (DTC) for blowdown valve attachment; selection of integral blowdown valves

Mounting: From horizontal to vertical (see Installation & Maintenance Instructions). Self-Draining and freeze-resistant when mounted in vertical position.

Line Sizes:

Model M3A: 3/8", 1/2", 3/4"

Model GM3: 1/2", 3/4", 1", 1-1/4", 1-1/2"

End Connections: Threaded NPT, BSPT, BSPP, SW, Raised Face Flanges (ANSI 150, DIN, BS, JIS)

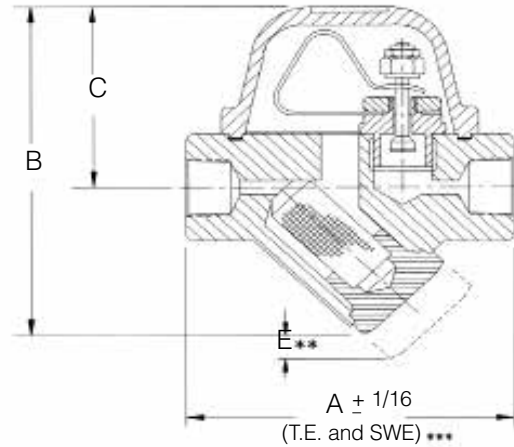

Model GM3						
1/2"-3/4"	A	B	C	D	E	Wt
inches	4	6	3.625	4	2.625	8.4 lbs
mm	102	152	92	102	67	3,8 kgs
1"	A	B	C	D	E	Wt
inches	5	6.75	3.625	4	3.50	9.9 lbs
mm	127	171	92	102	89	4,5 kgs
1-1/4", 1-1/2"	A	B	C	D	E	Wt
inches	7.125	9.50	5.875	6	4.375	33 lbs
mm	181	241	149	102	67	15 kgs
Model M3A						
3/8", 1/2", 3/4"	A	B	C	D	E	Wt
inches	4	5	3.25	3.125	2.25	5.5 lbs
mm	102	127	83	79	57	2,5 kgs

Notes: dimension D is overall width; ** dimension E is withdrawal distance for strainer, ***dimensions shown are for threaded or socket weld ends, contact factory for other dimensions

CAPACITY CHARTS: CONDENSATE CAPACITY AT OPERATING PRESSURE

Model GM3		For smaller loads, consider Model M3A						
Size	Operating Pressure, psi (bar)	2 (0,14)	5 (0,34)	10 (0,69)	15 (1,03)	20 (1,38)	25 (1,72)	30 (2,07)
1/2"	Cold start-up, lbs/hr	1000	1700	2100	2500	2900	3000	3200
	Hot (Dripleg), lbs/hr	500	700	750	750	750	750	750
3/4"	Cold start-up, Kg/hr	453	771	952	1134	1315	1360	1451
	Hot (Dripleg), Kg/hr	226	317	340	340	340	340	340
1"	Cold start-up, lbs/hr	1800	3200	5100	6800	8000	8900	9000
	Hot (Dripleg), lbs/hr	700	950	1300	1600	1700	1800	2000
	Cold start-up, Kg/hr	816	1451	2313	3129	3628	4037	4082
1-1/4"	Hot (Dripleg), Kg/hr	317	430	589	725	771	816	907
	Cold start-up, lbs/hr	4000	7000	10000	13000	16000	18000	20000
1-1/2"	Hot (Dripleg), lbs/hr	2400	2800	3200	3700	3900	4000	4100
	Cold start-up, Kg/hr	1814	3175	4536	5896	7257	8164	9072
	Hot (Dripleg), Kg/hr	1088	1270	1451	1678	1723	1814	1859
Model M3A		For smaller loads, consider Model DM6						
Size	Differential Pressure, psi (bar)	2 (0,14)	5 (0,34)	10 (0,69)	15 (1,03)	20 (1,38)	25 (1,72)	30 (2,07)
3/8"	Cold start-up, lbs/hr	500	1000	1800	2200	2600	2900	3000
	Hot (Dripleg), lbs/hr	175	200	200	200	200	200	200
1/2"	Cold start-up, Kg/hr	226	453	816	997	1179	1315	1360
	Hot (Dripleg), Kg/hr	79	90	90	90	90	90	90

Note: Flow rates are based on discharge to atmospheric pressure, valid for back pressure up to 20% of inlet pressure. Higher back pressure requires reset of control element to obtain these capacities. Consult factory for details.

FOR PROCESS AND HEATING SYSTEMS

SPECIFICATIONS (GM3 2" SIZE)

- Maximum Operating Pressure: 30 psi (2,1 bar)
- Maximum Allowable Pressure: 120 psig (8,3 bar)
- Maximum Allowable Temperature: 450°F (232°C)

MATERIALS

- Body: Ductile Iron A395
- Cover: Carbon Steel A516 Gr. 70
- Valve Seat & Stem: Stainless Steel 303 & 17-4
- Bi-Metal: Stainless Steel NiCr
- Strainer: Stainless Steel 304
- Bolts: ASTM-A193, B7
- Gasket: Flexible Graphite
- Options: Double Threaded Strainer Cap (DTC) for blowdown valve attachment; blowdown valve to fit 3/8" DTC for in-line strainer blowdown
- Mounting: From horizontal to vertical (see Installation & Maintenance Instructions). Self-draining and freeze-resistant when mounted in vertical position.
- Line Sizes: 2"
- End Connections: Threaded (NPT), ANSI 150 & 300 raised face flange

DIMENSIONS

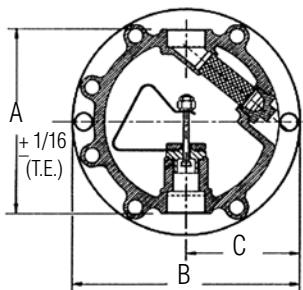

Model GM3 (2")					
2	A	B	C	D	Wt
inches	10.9	13.4	6.75	4.56	70 lbs
mm	277	340	171	116	32 kgs

Notes: dimension D is overall width

CAPACITY CHARTS: CONDENSATE CAPACITY AT OPERATING PRESSURE

Size	Operating Pressure, psi (bar)	Model GM3						
		2 (0,14)	5 (0,34)	10 (0,69)	15 (1,03)	20 (1,38)	25 (1,72)	30 (2,07)
2"	Cold start-up, lbs/hr	13000	20000	30000	35000	40000	45000	50000
	Hot (Dripleg), lbs/hr	5000	6300	7500	8500	9000	10000	11000

Note: Flow rates are based on discharge to atmospheric pressure, valid for back pressure up to 20% of inlet pressure. Higher back pressure requires reset of control element to obtain these capacities. Consult factory for details.

PRINCIPLES OF OPERATION

At the heart of every Bestobell steam trap is the unique delta-shaped element, a rugged single blade bimetal formed from high grade stainless steels. Coupled with the valve seat and stem, the element forms a single moving part that is unaffected by dirt and wear. The design provides a sophisticated force balanced valve that utilizes both *thermostatic* and *thermodynamic* forces to provide modulating discharge, and prevent the loss of live steam.

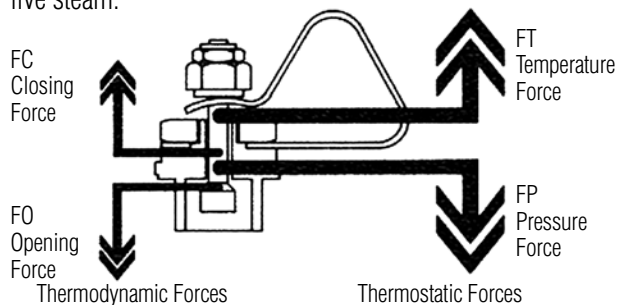

The *thermostatic* effect combines a temperature closing force (FT) generated by the element, and a pressure opening force (FP) generated by the differential pressure across the seat. When condensate temperature approaches that of saturated steam, bimetal expansion raises the stem to close the control valve. Lower temperature condensate, however, relaxes the bimetal to open the valve. With this valve opening, the system differential pressure acts on the diameter of the plug providing an increase in opening force and discharge capacity.

The *thermodynamic* forces are introduced through a three stage orifice containing an expansion chamber forced between the seat and the skirt of the valve stem. The controlled generation of flash steam within this chamber increases the intermediate pressure and resultant opening force (FO) on the valve to increase hot discharge capacity. When the temperature increases, and discharge decreases, the flashing takes pace closer to the seat at the entrance to the expansion chamber. A sudden reduction in the opening force allows the closing force (FC) to take over and pull the valve tightly onto the seat. This assures tight shutoff preventing loss of live steam.