

Valves

High Pressure OEM Valves

Series 6140, 6180

Patent# 3,014,499

Features

- ▶ Original Shear-Seal® technology
- ▶ Low pressure drop
- ▶ Tolerates contaminants
- ▶ Spring return option
- ▶ Flexible design for OEM requirements

Applications

- ▶ Hydraulic presses
- ▶ Military equipment
- ▶ Paper mill controls
- ▶ Hydraulic pilot valves
- ▶ Railroad maintenance equipment
- ▶ Halon fill systems



General Specifications*

Working Pressure:	Hydraulic fluid up to 3000 psi (206 bar)
Flow Capacity, Cv:	See table
Back Pressure:	Must not exceed 250 psi (17.2 Bar) at return port for satisfactory operation
Pressure Drop:	14 psi (0.96 bar) at 20 ft/sec See Supplemental Guide for more detailed information
Proof Pressure:	1-1/2 times working pressure except at return port
Burst Pressure:	2-1/2 times working pressure except at return port (see flow chart)

Media Temperature Range:	-40° to +250°F (-40° to +121°C)
Wetted Material:	
Rotor:	Hard anodized aluminum
Pressure Seals:	Brass
Shaft:	Stainless steel
Body Housing:	Anodized aluminum
Bearings:	Carbon steel
Standard O-rings:	Buna N, others available
Back-up Rings:	PTFE

* See product configurator for additional options.

FLOW PATTERNS (VIEWED FROM SHAFT END)

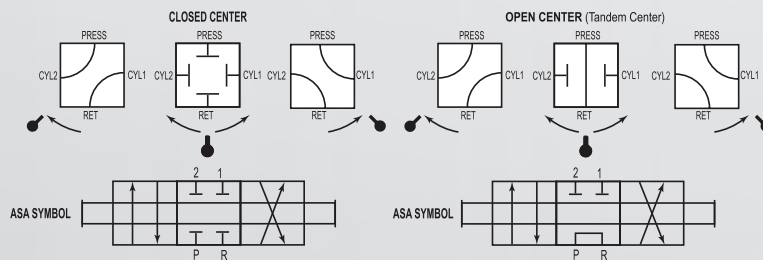

Main Valve Port Size	Flow Capacity (Approx.) Service: Oil			Min. Flow Passage Dia.	Cv Factor	Approx. Shipping Weight lbs (kgs)	Return Port Burst Rating
	20 ft/sec gpm (l/min)	40 ft/sec gpm (l/min)	60 ft/sec gpm (l/min)				
1/4" & 3/8"	5 (19)	10 (38)	Use Heavy Duty Valve	5/16"	1.56	1.7 (0.8)	3,000 psi (207 bar)
1/2" & 3/4"	14 (53)	28 (106)		17/32"	4.80	3.8 (1.7)	
** 1"	25 (95)	51 (190)		23/32"	9.20	7.6 (3.5)	2,000 psi (138 bar)
** 1-1/2"	62 (235)	124 (471)		1-1/8"	24.0	18.5 (8.4)	1,500 psi (103 bar)

** 6140 Series only

Barksdale®
CONTROL PRODUCTS
Barksdale, Inc./Barksdale GmbH
A Subsidiary of Crane Co.

High Pressure OEM Valves

Series 6140, 6180

Technical Drawings

6140 Series

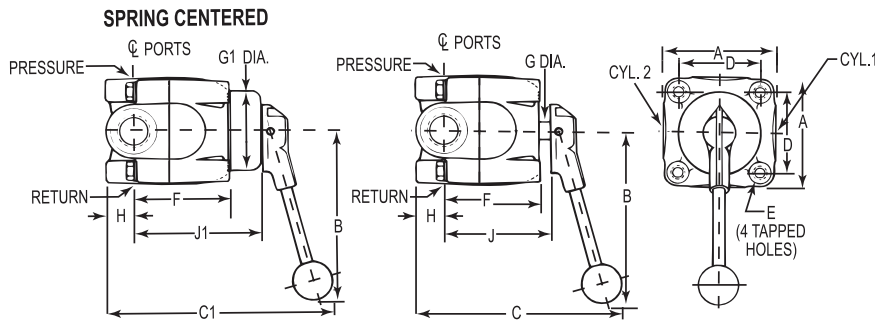

6180 Series

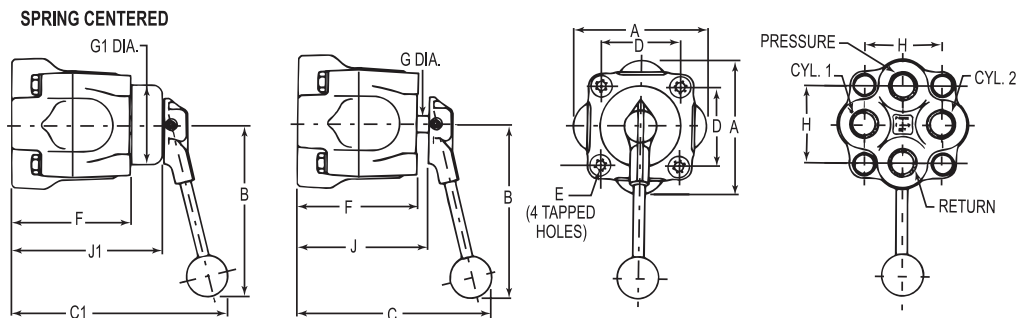

6140 Series In-Line (side) Porting

Port Size NPT	A	B	C	C1	D	E	F	G Dia.	G1 Dia.	H	J	J1
1/4" & 3/8"	2.63 (66.8)	5.44 (138)	6.38 (161.9)	6.718 (170.6)	1.81(46.0)	5/16 - 18 NC	2.31(58.7)	0.44 (11.2)	1.91(48.5)	0.56 (14.2)	2.66 (67.6)	3.03 (77.0)
1/2" & 3/4"	3.5 (88.9)	5.44 (138)	7.37 (187)	7.93 (201)	2.56 (65.0)	3/8 - 16 NC	3.03 (77.0)	0.56 (14.2)	2.56 (65.0)	0.88 (22.4)	3.38 (85.9)	3.94 (100)
1"	4.5 (114)	8.44 (214)	8.16 (207)	9.03 (229.3)	3.31 (84.1)	1/2 - 13 NC	3.59 (91.2)	0.75 (19.1)	3.38 (86)	1.06 (26.9)	3.94 (100)	4.81 (122)
1-1/2"	6.38 (162)	10.35 (263)	9.66 (245)	10.53 (268)	4.75 (121)	3/4 - 10 NC	4.6 (118)	0.88 (22.4)	3.38 (86)	1.34 (34.0)	5.03 (128)	5.91 (150)

6180 Series Straight (bottom) Porting

Port Size NPT	A	B	C	C1	D	E	F	G Dia.	G1 Dia.	H	J	J1
1/4" & 3/8"	2.63 (66.8)	5.44 (138)	6.13 (156)	6.50 (165)	1.81(46.0)	5/16 - 18 NC	2.66 (67.6)	0.44 (11.2)	1.91(48.5)	1.50 (38.1)	3.00 (76.2)	3.38 (85.9)
1/2" & 3/4"	4.19 (106)	5.44 (138)	7.34 (186)	7.91 (201)	2.56 (65.0)	3/8 - 16 NC	3.88 (98.6)	0.56 (14.2)	2.56 (65.0)	2.50 (63.5)	4.22 (107)	4.78 (121)

Dimensions in inches (mm)

Product Configurator

Example: **614** **2** **R** **3** **H** **C** **3**

Series

- 614** Regular (side) porting
- 618 Straight (bottom) porting

Port Size

- 1** 1/4" NPT ports
- 2** 3/8" NPT ports
- 3** 1/2" NPT ports
- 4** 3/4" NPT ports
- 5** 1" NPT ports (614 only)
- 7 1-1/2" NPT ports (614 only)

Style

- R** Regular (side) porting (series 614)
- S Straight (bottom) porting (series 618)

* Highlighted options represent those most frequently used. Select these common options for improved availability. (5/21)

Pressure

- 3** 3,000 psi

Working Media

- H** Hydraulic oil

Flow Pattern

- C** Closed center
- O** Open center (tandem center)

Position

- 3** 3-position

Options

See Supplemental Guide for complete list

Options

- A SAE Porting
- MC Spring centering *
- NF Non-interflow (port size 1/4" and 3/8" NPT only)

* For 1" ported pressure rating 2,500 psi
Not available on 1-1/2" ported valves.