



ANDERSON GREENWOOD SERIES 5200 PILOT OPERATED PRESSURE RELIEF VALVES

A modulating pilot operated pressure relief valve for economizer applications that meets the stringent requirements of ASME Section I at high temperatures



FEATURES

- Increased system output with total valve tightness to 96 percent of set pressure without leakage.
- All plastic pilot seats and seals provide chemical compatibility with corrosion inhibitors in feedwater service.
- Balanced design ensures proper valve operation and lift unaffected by back pressure; pilot exhausts to main valve outlet with no effect on set pressure.
- Reduced product loss and pollution through soft seats for premium tightness before and after relief cycles.
- Modulating action minimizes flow and resultant noise during normal system upset, reducing noise abatement costs.
- Non-flowing pilot reduces seat wear and minimizes entrance of dirt and particulates.
- Easy, single set pressure adjustment is accurate and dependable.
- ASME Section I stamp for steam and water service; ASME Section VIII for steam also available.
- Rugged bracket pilot mounting protects against vibration and careless handling.

GENERAL APPLICATION

The Series 5200 has ASME Section I certified capacities for both steam and water and uses a full nozzle design and metal main valve seat to meet high temperature requirements up to 705°F (373°C).

TECHNICAL DATA

Sizes:	1½" x 2" to 8" x 10" (38 mm to 200 mm)
Orifices:	F 0.307 to T 26.00 in ² (1.98 to 167.7 cm ²)
Inlet ratings:	ANSI Class 150 to 2500
Temperature range:	to 705°F (373°C)
Set pressures:	15 to 3200 psig (1.03 to 221 barg)
Code:	ASME I and VIII

ANDERSON GREENWOOD SERIES 5200 PILOT OPERATED PRESSURE RELIEF VALVES

PRODUCT OVERVIEW

The Series 5200's standard condensate trap condenses steam into water prior to entering the pilot, providing a liquid condensate temperature barrier between the plastic soft sealed pilot and main valve. This also creates piston seal cooling via conduction from condensing steam around the liner. There are no pilot component changes required to handle service conditions changing to and from steam and water.

Its unique design enables the main valve to be tight at pressures up to set point. After relieving and reseating, it stays bubble-tight, cycle after cycle.

SPECIFICATIONS

- Body bowl drain (Section I).
- Lifting lever standard on ASME Section I service.
- Pilot condensate trap standard.
- Remote sensing standard.
- Optional accessories include:
 - Field test connection
 - Pilot gag
 - Sense ring (for sensing at valve inlet)

OPERATION

In normal operation, the system pressure acts on the area contained by the main valve seat at the bottom of the free-floating differential area piston and on the top of the piston. As the top of the piston is larger than the bottom (seat area), there is a large downward net force holding it closed. Under static conditions, the seating force increases as the system pressure increases and approaches set point.

Just prior to set pressure, the pilot opens and partially depressurizes the dome, reducing the force on the top of the piston. The set pressure is the point where the upward force on the main valve seat area can overcome the reduced downward loading. This causes the piston to lift, resulting in modulated flow through the main valve. As the main valve is relieving, the flow through the pilot stops.

When the relief demand has been satisfied, the pilot closes, full system pressure is diverted to the dome and the piston moves downwards, closing the main valve.

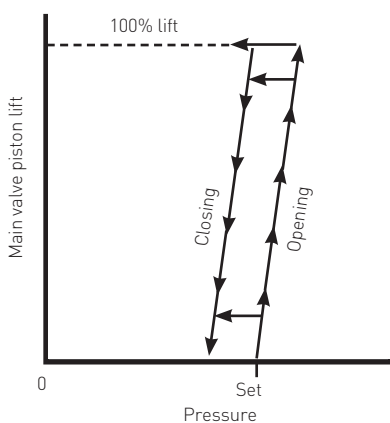
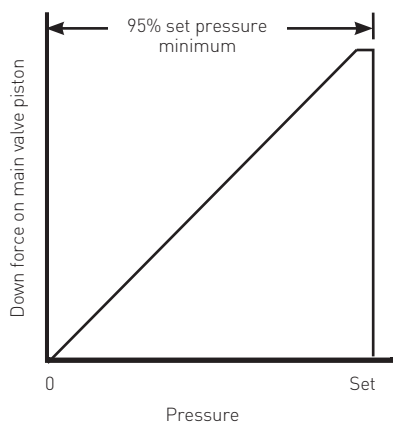

ANDERSON GREENWOOD SERIES 5200 PILOT OPERATED PRESSURE RELIEF VALVES

OPERATION

Main valve closed

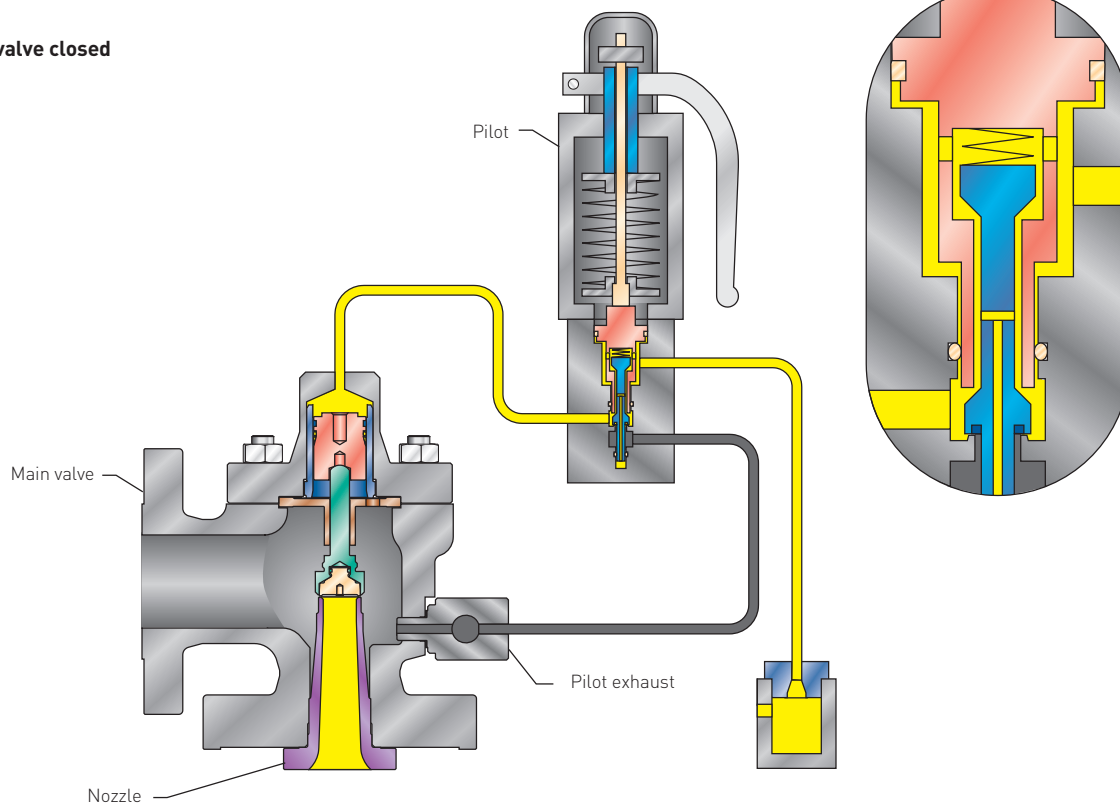

Main valve modulating

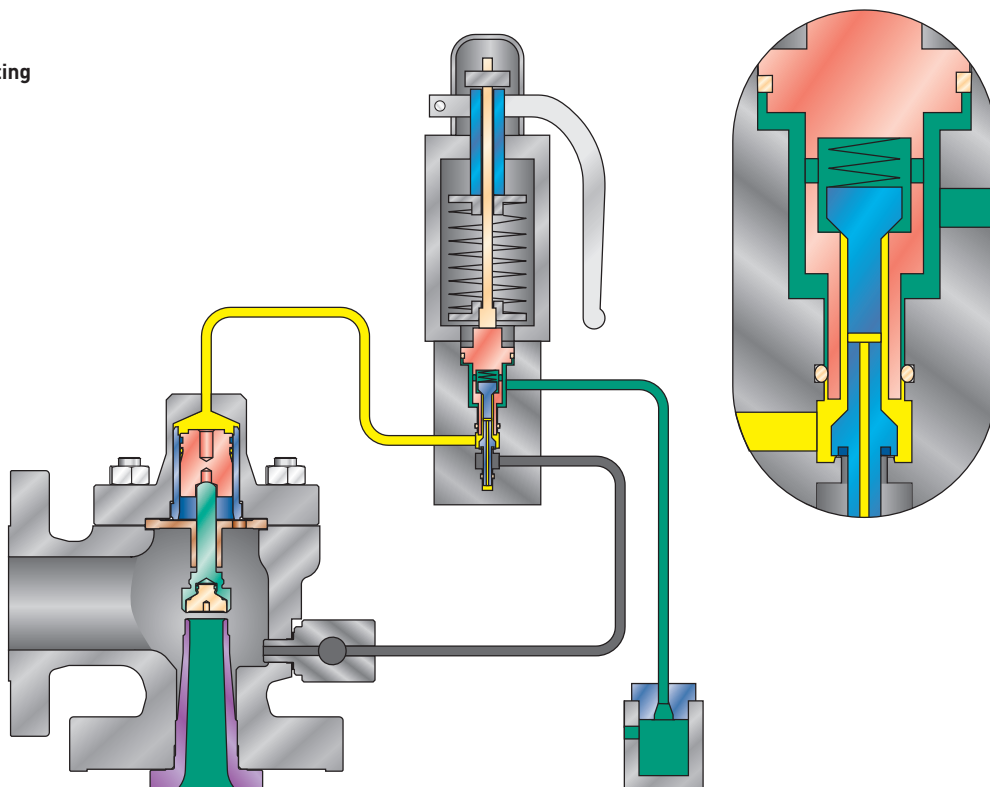

ANDERSON GREENWOOD SERIES 5200 PILOT OPERATED PRESSURE RELIEF VALVES

OPERATION

Main valve open

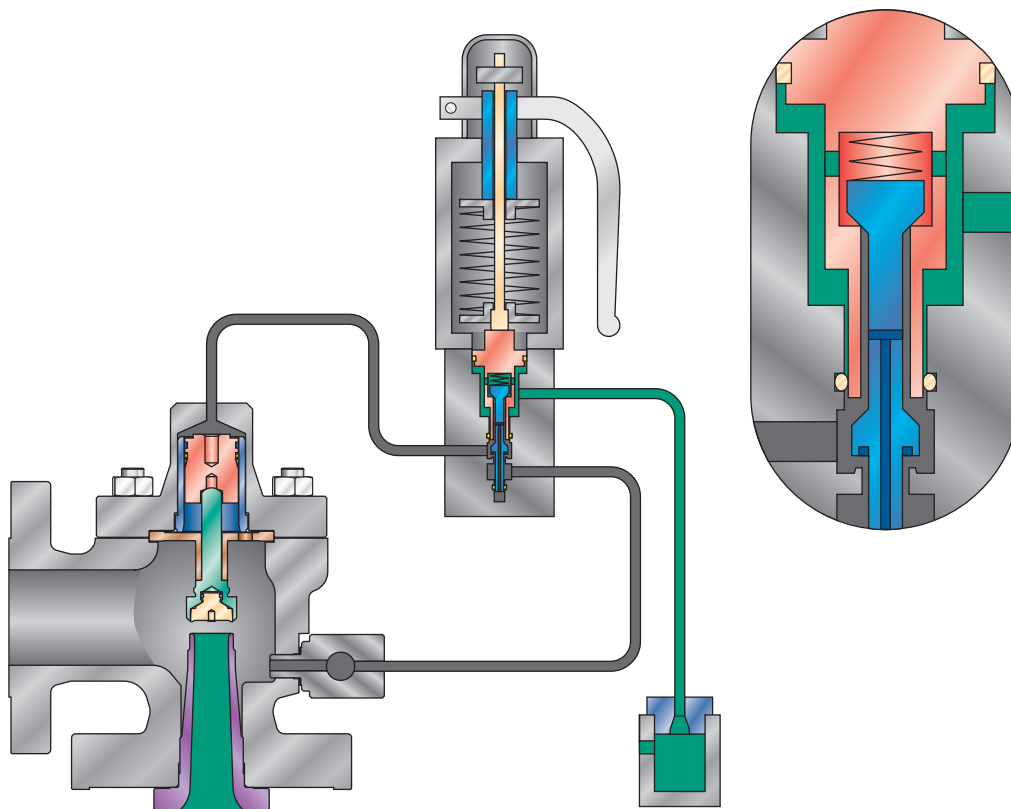

SIZING EFFECTIVE API ORIFICE AREA, IN² (cm²)

Inlet size	Outlet size	Type 5247 flow area	Set pressure range in psig (barg)
1.5	2", 2.5	0.307 (1.981) (F)	15 to 3200 (1.034 to 220.6)
1.5	2.5, 3"	0.503 (3.245) (G)	15 to 3200 (1.034 to 220.6)
2	3	0.503 (3.245) (G)	15 to 3200 (1.034 to 220.6)
1.5	3	0.785 (5.065) (H)	15 to 3200 (1.034 to 220.6)
2	3	0.785 (5.065) (H)	15 to 3200 (1.034 to 220.6)
2	3	1.287 (8.303) (J)	15 to 290 (1.034 to 19.99)
2	4	1.287 (8.303) (J)	15 to 3200 (1.034 to 220.6)
2.5	4	1.287 (8.303) (J)	15 to 2250 (1.034 to 155.1)
3	4	1.287 (8.303) (J)	15 to 3200 (1.034 to 220.6)
2.5	4	1.838 (11.86) (K)	15 to 2250 (1.034 to 155.1)
3	4	1.838 (11.86) (K)	15 to 2250 (1.034 to 155.1)
3	4	2.853 (18.41) (L)	15 to 750 (1.034 to 51.71)
3	6	2.853 (18.41) (L)	15 to 2250 (1.034 to 155.1)
4	6	2.853 (18.41) (L)	15 to 2250 (1.034 to 155.1)
4	6	3.60 (23.23) (M)	15 to 2250 (1.034 to 155.1)
4	6	4.34 (28.00) (N)	15 to 1500 (1.034 to 103.4)
4	6	6.38 (41.16) (P)	15 to 1500 (1.034 to 103.4)
6	8	11.05 (71.29) (Q)	15 to 1500 (1.034 to 103.4)
6	8", 10	16.00 (103.2) (R)	15 to 1500 (1.034 to 103.4)
8	10	26.00 (167.7) (T)	15 to 1500 (1.034 to 103.4)

NOTES

1. Set pressure range is 15 - 1500 psi
2. Set pressure range is 15 - 2250 psi
3. Set pressure range is 15 - 750 psi
4. Set pressure ranges are at ambient temperature. Refer to ASME B16.5 for pressure limits at elevated temperatures.

ANDERSON GREENWOOD SERIES 5200 PILOT OPERATED PRESSURE RELIEF VALVE

MATERIALS OF CONSTRUCTION

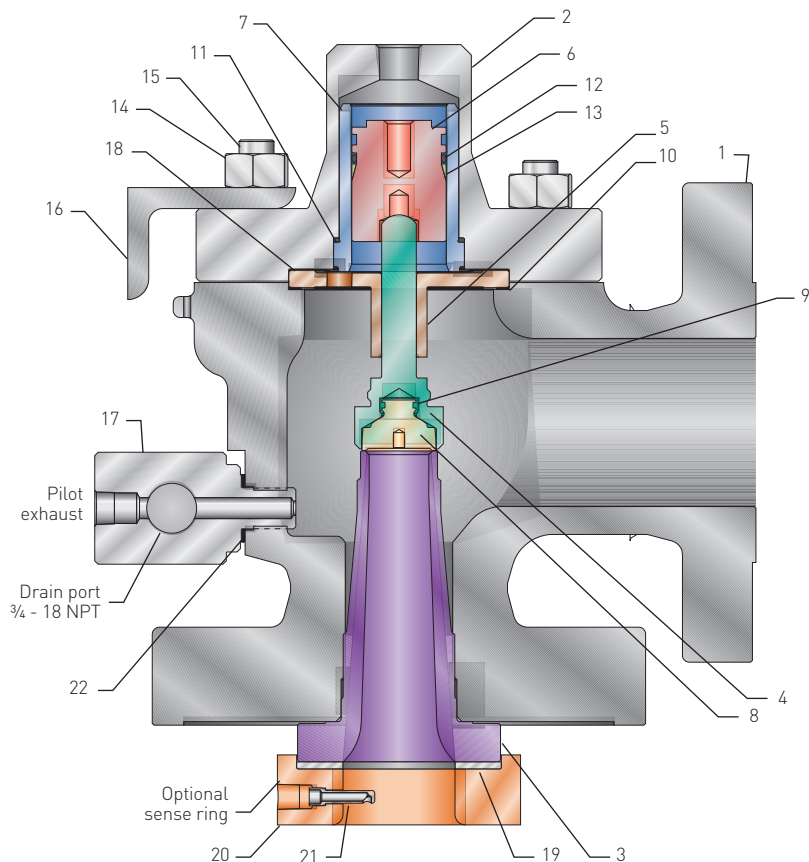

Item no.	Description	Material	
		/S1 Trim	/S3 Trim
1	Body	STL SA216-WCB/WCC	STL SA217-WC6
2	Cap	STL SA105	STL SA105
3	Nozzle	SST SA351-CF8M	SST SA351-CF8M
4	Disc holder	SST SA351-CF3M	SST SA351-CF3M
5	Guide	SST A297-HE	SST A297-HE
6	Piston	SST 17-4 PH1150	SST 17-4 PH1150
7	Liner	SST 316 ²	SST 316 ²
8	Disc insert	SST 316	SST 316
9	Retaining clip	Inconel® X750	Inconel® X750
10	Gasket	SST 316	SST 316
11	Liner seal	EPDM	EPDM
12	Piston seal	EPDM	EPDM
13	Wedge ring	PTFE ³	PTFE ³
14	Nut	STL SA194-2H or NI ALY SB637-N07718 ⁴	
15	Stud	STL SA193-B7 or SB637-No7718 ⁴	
16	Bracket	STL A36	STL A36
17	Body drain fitting	SST 316	SST 316
18	Gasket	Organic fiber	Organic fiber
19	Gasket	SST 316L/graphite	SST 316L/graphite
20 ¹	Sense ring	SST 316	SST 316
21 ¹	Pitot tube	SST 316	SST 316
22 ¹	Gasket	Organic fiber	Organic fiber

NOTES

1. Remote sense standard, internal sense optional.
2. SST 17-4 PH1150 for 900# through 2500# inlet.
3. 35% carbon filled.
4. Chrome-Moly studs and carbon steel nuts or Inconel® 718 studs and nuts, depending on valve size and pressure class.

Note - unless otherwise specified

ANDERSON GREENWOOD SERIES 5200 PILOT OPERATED PRESSURE RELIEF VALVES

MATERIALS OF CONSTRUCTION

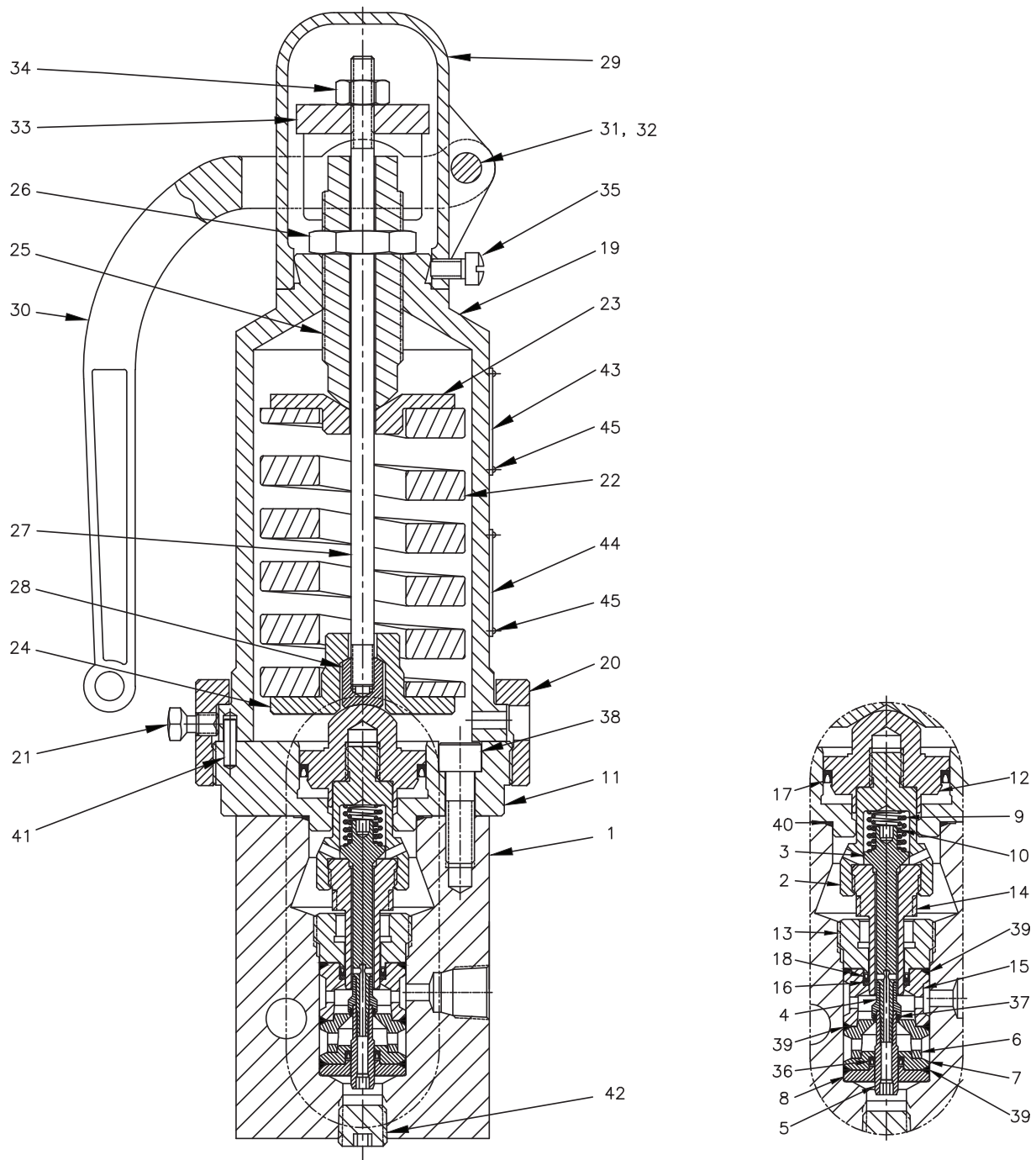

ANDERSON GREENWOOD SERIES 5200 PILOT OPERATED PRESSURE RELIEF VALVES

MATERIALS OF CONSTRUCTION

PILOT MATERIALS OF CONSTRUCTION

Item	Description	Material
1	Body	SST 316
2	Piston connector	SST 316
3	Inlet seat	SST 316
4	Exhaust seat retainer	SST 316
5	Exhaust seat stem	SST 316
6	Exhaust nozzle	SST 316
7	Exhaust washer	SST 316
8	Stop washer	SST 316
9	Outer spool spring	Inconel® X750
10	Inner spool spring	Inconel® X750
11	Piston plate	SST 316
12	Piston	SST 316
13	Bushing	SST 316
14	Inlet nozzle	SST 316
15	Dome spool	SST 316
16	Dome seal backup ring	PEEK
17	Piston seal	PTFE/Elgiloy
18	Dome seal	PTFE/Elgiloy
19	Spring bonnet	SST 316
20	Bonnet ring	SST 316
21	Bonnet ring screw	SST 18-8
22	Spring	SST 316
23	Washer spring (upper)	SST 316
24	Washer spring (lower)	SST 316
25	Set pressure screw	SST 17-4 PH1150
26	Adjusting screw locknut	SST 316
27	Lifting rod	SST 17-4 PH1150
28	Spindle lift lever bushing	SST 316
29	Lift lever cap	SST SA351-CF8M
30	Lift lever	SST SA351-CF8M
31	Lift lever pin	SST 316
32	Cotter pin	SST 18-8
33	Spindle nut	SST 316
34	Hex nut	SST 18-8
35	Lift lever cap screw	SST 18-8
36	Stem seal	PTFE/Elgiloy
37	Exhaust seat	PTFE/15% graphite
38	Piston plate screw	SST 17-4 PH1150
39	Spool/body seal	PTFE TFE
40	Body/piston plate seal	PTFE TFE
41	Roll pin	SST 420
42	Pipe ¼ NPT plug	SST 316
43	Pilot nameplate	SST 18-8
44	Nameplate - patents	SST 18-8
45	Drive pin	SST 18-8

ANDERSON GREENWOOD SERIES 5200 PILOT OPERATED PRESSURE RELIEF VALVES

DIMENSIONS

DIMENSIONS AND WEIGHTS

Orifice	Size		A ^[5]		B		C max ^{[4] [5]}		D max		E max		F max		Weight	
	in x out	Rating in x out	in	mm	in	mm	in	mm	in	mm	in	mm	in	mm	lbs	kgs
F	1.5 x 2	150 x 150 ^[1]	4 ⁷ / ₈	123.8	4 ³ / ₄	120.7	18.58	472	10.96	278	17.50	445	17.50	445	59	27
		300/600 x 150	4 ⁷ / ₈	123.8	6	152.4	18.58	472	10.96	278	17.50	445	17.50	445	63	28
	1.5 x 2.5	900/1500 x 300	4 ⁷ / ₈	123.8	6	152.4	18.83	478	11.47	291	17.50	445	17.50	445	87	39
G	1.5 x 2.5	2500 x 300	5 ¹ / ₂	139.7	6 ¹ / ₂	165.1	19.56	497	11.84	301	17.50	445	17.50	445	114	52
		150 x 150 ^[1]	4 ⁷ / ₈	123.8	4 ³ / ₄	120.7	19.05	484	10.96	278	17.50	445	17.50	445	67	30
		300/600 x 150	4 ⁷ / ₈	123.8	6	152.4	19.05	484	10.96	278	17.50	445	17.50	445	71	32
	1.5 x 3	900/1500 x 300	4 ⁷ / ₈	123.8	6	152.4	19.05	484	11.84	301	17.50	445	17.50	445	102	46
		150 x 150 ^[1]	4 ⁷ / ₈	123.8	4 ³ / ₄	120.7	19.05	484	10.96	278	17.50	445	17.50	445	69	31
		300/600 x 150	4 ⁷ / ₈	123.8	6	152.4	19.05	484	10.96	278	17.50	445	17.50	445	71	32
H	2 x 3	900 x 300	4 ⁷ / ₈	123.8	6	152.4	19.05	484	11.84	301	17.50	445	17.50	445	102	46
		2500 x 300	6 ¹ / ₈	155.6	6 ³ / ₄	171.5	19.98	508	11.84	301	17.50	445	17.50	445	138	62
		150 x 150 ^[1]	5 ¹ / ₈	130.2	4 ⁷ / ₈	123.8	18.74	476	10.96	278	17.50	445	17.50	445	65	30
	1.5 x 3	300/600 x 150	5 ¹ / ₈	130.2	4 ⁷ / ₈	123.8	18.74	476	10.96	278	17.50	445	17.50	445	68	31
		900 x 150	6 ⁷ / ₁₆	166.7	6 ³ / ₈	161.9	20.55	522	11.84	301	17.50	445	17.50	445	107	49
		1500 x 300	6 ⁷ / ₁₆	166.7	6 ³ / ₈	161.9	20.55	522	11.84	301	17.50	445	17.50	445	111	50
	2 x 3	300/600 x 150	5 ¹ / ₈	130.2	4 ⁷ / ₈	123.8	18.74	476	10.96	278	17.50	445	17.50	445	68	31
		900 x 150	6 ¹ / ₁₆	154.0	6 ³ / ₈	161.9	20.05	509	11.84	301	17.50	445	17.50	445	120	54
		1500 x 300	6 ¹ / ₁₆	154.0	6 ³ / ₈	161.9	20.05	509	11.84	301	17.50	445	17.50	445	125	57
J	2 x 3	150 x 150 ^[1]	5 ³ / ₈	136.5	4 ⁷ / ₈	123.8	19.84	504	11.22	285	17.50	445	17.50	445	79	36
		300 x 150 ^{[1][3]}	5 ³ / ₈	136.5	4 ⁷ / ₈	123.8	19.84	504	11.22	285	17.50	445	17.50	445	80	36
		900 x 150 ^[1]	7 ¹ / ₄	184.2	7 ¹ / ₈	181.0	22.49	571	12.39	315	17.50	445	17.50	445	162	73
	2 x 4	300 x 150	5 ⁷ / ₈	149.2	5 ⁵ / ₈	142.9	20.43	519	11.22	285	17.50	445	17.50	445	89	40
		600 x 150	6 ¹ / ₈	155.6	6 ³ / ₄	171.5	20.68	525	12.06	306	17.50	445	17.50	445	103	47
		900 x 150 ^[1]	7 ¹ / ₄	184.2	7 ¹ / ₈	181.0	22.49	571	12.39	315	17.50	445	17.50	445	162	73
	2.5 x 4	900 x 150 ^[2]	6 ¹ / ₈	155.6	6 ³ / ₄	171.5	20.68	525	12.06	306	17.50	445	17.50	445	120	55
		1500 x 300	7 ¹ / ₄	184.2	7 ¹ / ₈	181.0	22.49	571	12.39	315	17.50	445	17.50	445	171	77
		300 x 150	5 ³ / ₈	136.5	5 ⁵ / ₈	142.9	19.93	506	11.22	285	17.50	445	17.50	445	93	42
	3 x 4	600 x 150	6 ¹ / ₈	155.6	6 ³ / ₄	171.5	20.68	525	12.06	306	17.50	445	17.50	445	110	50
		900 x 150 ^[2]	6 ¹ / ₈	155.6	6 ³ / ₄	171.5	20.68	525	12.06	306	17.50	445	17.50	445	130	59
		300 x 150	7 ¹ / ₄	184.2	7 ¹ / ₈	181.0	21.81	554	11.22	285	17.50	445	17.50	445	105	48
600 x 150		7 ¹ / ₄	184.2	7 ¹ / ₈	181.0	21.81	554	12.06	306	17.50	445	17.50	445	118	54	
900 x 150		7 ¹ / ₄	184.2	7 ¹ / ₈	181.0	22.49	571	12.39	315	17.50	445	17.50	445	177	80	
1500 x 300		7 ¹ / ₄	184.2	7 ¹ / ₈	181.0	22.65	575	12.39	315	17.50	445	17.50	445	196	89	
K	2.5 x 4	150 x 150 ^[1]	6 ¹ / ₈	155.6	6 ³ / ₈	161.9	20.74	527	12.06	306	17.50	445	17.50	445	101	46
		300 x 150	6 ¹ / ₈	155.6	6 ³ / ₈	161.9	20.74	527	12.06	306	17.50	445	17.50	445	102	46
		600 x 150	7 ¹ / ₄	184.2	7 ¹ / ₈	181.0	21.99	558	12.39	315	17.50	445	17.50	445	120	55
	3 x 4	900 x 150	7 ¹ / ₄	184.2	7 ¹ / ₈	181.0	21.99	558	12.39	315	17.50	445	17.50	445	155	70
		150 x 150 ^[1]	6 ¹ / ₈	155.6	6 ³ / ₈	161.9	20.74	527	12.06	306	17.50	445	17.50	445	104	47
		300 x 150	6 ¹ / ₈	155.6	6 ³ / ₈	161.9	20.74	527	12.06	306	17.50	445	17.50	445	108	49
	600 x 150	7 ¹ / ₄	184.2	7 ¹ / ₈	181.0	21.99	558	12.39	315	17.50	445	17.50	445	128	58	
		900 x 150	7 ¹ / ₄	184.2	7 ¹ / ₈	181.0	21.99	558	12.39	315	17.50	445	17.50	445	141	64

NOTES

1. Available in WCB body material only
2. Available in WC6 body material only
3. Limited to 285 psig set pressure
4. For set pressure above 3705 psig, increase Cmax dimension by 0.75 in (19.05 mm) and weight by 8 lbs (3.6 kgs)
5. For integral sense with RF, add 1.06" to A and Cmax dimensions. (Integral sense not offered with RTJ)

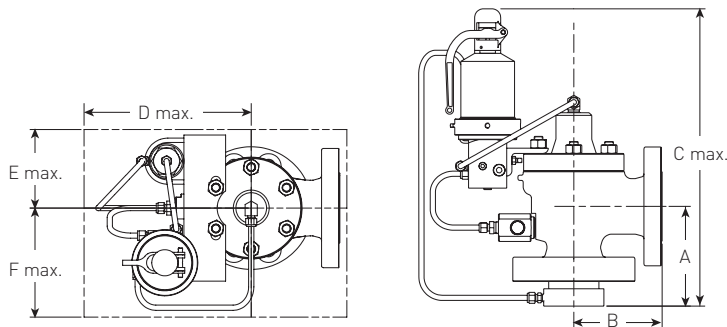

ANDERSON GREENWOOD SERIES 5200 PILOT OPERATED PRESSURE RELIEF VALVES

DIMENSIONS

DIMENSIONS AND WEIGHTS (Continued)

Orifice	Size		A ^[5]		B		C max ^{[4] [5]}		D max		E max		F max		Weight	
	in	x out	in	mm	in	mm	in	mm	in	mm	in	mm	in	mm	lbs	kgs
L	3 x 4	150 x 150 ^[1]	6 ¹ / ₈	155.6	6 ¹ / ₂	165.1	22.79	579	12.39	315	17.50	445	17.50	445	123	56
		300 x 150	6 ¹ / ₈	155.6	6 ¹ / ₂	165.1	22.79	579	12.39	315	17.50	445	17.50	445	126	57
	3 x 6	600 x 150	8	203.2	8	203.2	24.14	613	13.11	333	17.50	445	17.50	445	168	76
		900 x 150	8	203.2	8	203.2	24.14	613	13.11	333	17.50	445	17.50	445	181	82
		150 x 150 ^[1]	7 ¹ / ₁₆	179.4	7 ¹ / ₈	181.0	23.01	585	12.39	315	17.50	445	17.50	445	143	65
M	4 x 6	300 x 150	7 ¹ / ₁₆	179.4	7 ¹ / ₈	181.0	23.01	585	12.39	315	17.50	445	17.50	445	150	68
		600 x 150	7 ¹ / ₁₆	179.4	8	203.2	23.20	589	13.11	333	17.50	445	17.50	445	185	84
		900 x 150	7 ³ / ₄	196.9	8 ³ / ₄	222.3	24.40	620	13.28	337	17.50	445	17.50	445	247	112
		150 x 150 ^[1]	7	177.8	7 ¹ / ₄	184.2	24.01	610	13.11	333	17.50	445	17.50	445	167	76
		300 x 150	7	177.8	7 ¹ / ₄	184.2	24.01	610	13.11	333	17.50	445	17.50	445	173	79
N	4 x 6	600 x 150	7	177.8	8	203.2	24.01	610	13.11	333	17.50	445	17.50	445	186	84
		900 x 150	7 ³ / ₄	196.9	8 ³ / ₄	222.3	24.82	630	13.11	333	17.50	445	17.50	445	204	92
		150 x 150 ^[1]	7 ³ / ₄	196.9	8 ¹ / ₄	209.6	25.21	640	13.11	333	17.50	445	17.50	445	179	81
P	4 x 6	300 x 150	7 ³ / ₄	196.9	8 ¹ / ₄	209.6	25.21	640	13.11	333	17.50	445	17.50	445	185	84
		600 x 150	7 ³ / ₄	196.9	8 ³ / ₄	222.3	25.21	640	13.11	333	17.50	445	17.50	445	197	89
		150 x 150 ^[1]	7 ¹ / ₈	181.0	9	228.6	24.69	627	13.63	346	17.50	445	17.50	445	193	88
Q	6 x 8	300 x 150	8 ⁷ / ₈	225.4	10	254.0	26.44	672	13.63	346	17.50	445	17.50	445	211	96
		600 x 150	8 ⁷ / ₈	225.4	10	254.0	26.40	671	14.21	361	17.50	445	17.50	445	257	117
		150 x 150 ^[1]	9 ⁷ / ₁₆	239.7	9 ¹ / ₂	241.3	27.8	706	14.73	374	17.5	445	17.5	445	316	143
R	6 x 8	300 x 150	9 ⁷ / ₁₆	239.7	9 ¹ / ₂	241.3	27.8	706	14.73	374	17.5	445	17.5	445	333	151
		600 x 150	9 ⁷ / ₁₆	239.7	9 ¹ / ₂	241.3	27.8	706	14.73	374	17.5	445	17.5	445	370	168
		150 x 150 ^[1]	9 ⁷ / ₁₆	239.7	9 ¹ / ₂	241.3	29.51	749	15.16	385	17.5	445	17.5	445	390	177
T	8 x 10	300 x 150	9 ⁷ / ₁₆	239.7	10 ¹ / ₂	266.7	29.51	749	15.16	385	17.5	445	17.5	445	408	185
		600 x 150	9 ⁷ / ₁₆	239.7	10 ¹ / ₂	266.7	29.51	749	15.16	385	17.5	445	17.5	445	431	196
		150 x 150 ^[1]	10 ⁷ / ₈	276.2	11	279.4	33.01	839	16.6	422	17.5	445	17.5	445	587	266
T	300 x 150	10 ⁷ / ₈	276.2	11	279.4	33.01	839	16.6	422	17.5	445	17.5	445	604	274	

NOTES

1. Available in WCB body material only
2. Available in WC6 body material only
3. Limited to 285 psig set pressure
4. For set pressure above 3705 psig, increase Cmax dimension by 0.75 in (19.05 mm) and weight by 8 lbs (3.6 kgs)
5. For integral sense with RF, add 1.06" to A and Cmax dimensions. (Integral sense not offered with RTJ)

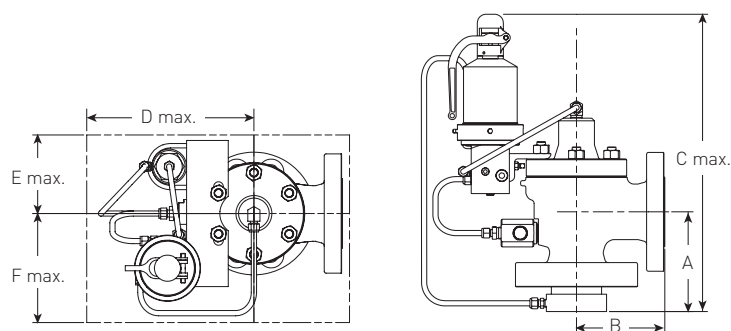

ANDERSON GREENWOOD SERIES 5200 PILOT OPERATED PRESSURE RELIEF VALVES

CAPACITIES

CAPACITY TABLES - SECTION I STEAM

Orifice designation		F		G		H		J	
Orifice area		in ²	cm ²	in ²	cm ²	in ²	cm ²	in ²	in ²
Set pressure		0.307	1.981	0.503	3.245	0.785	5.065	1.287	8.303
psig		Orifice capacity							
barg	lbs/hr	kg/hr	lbs/hr	kg/hr	lbs/hr	kg/hr	lbs/hr	kg/hr	
15	1.03	497	226	813	369	1.271	577	2.083	945
20	1.38	576	261	942	427	1.472	668	2.411	1.094
30	2.07	733	332	1.198	543	1.873	850	3.068	1.392
40	2.76	890	404	1.455	660	2.274	1.032	3.725	1.690
50	3.45	1.047	475	1.711	776	2.675	1.213	4.382	1.988
60	4.14	1.203	546	1.968	893	3.076	1.395	5.039	2.286
70	4.83	1.362	618	2.227	1.010	3.481	1.579	5.703	2.587
80	5.52	1.524	691	2.491	1.130	3.894	1.766	6.379	2.894
90	6.21	1.685	764	2.755	1.250	4.308	1.954	7.056	3.201
100	6.89	1.847	838	3.020	1.370	4.721	2.141	7.733	3.508
120	8.27	2.170	984	3.548	1.609	5.547	2.516	9.086	4.121
140	9.65	2.493	1.131	4.077	1.849	6.373	2.891	10.440	4.735
160	11.03	2.816	1.278	4.605	2.089	7.199	3.266	11.793	5.349
180	12.41	3.140	1.424	5.134	2.329	8.026	3.640	13.147	5.963
200	13.79	3.463	1.571	5.662	2.568	8.852	4.015	14.500	6.577
220	15.17	3.786	1.717	6.191	2.808	9.678	4.390	15.853	7.191
240	16.55	4.109	1.864	6.719	3.048	10.504	4.765	17.207	7.805
260	17.93	4.433	2.011	7.248	3.288	11.330	5.139	18.560	8.419
280	19.31	4.756	2.157	7.776	3.527	12.157	5.514	19.914	9.033
300	20.68	5.079	2.304	8.305	3.767	12.983	5.889	21.267	9.647
320	22.06	5.402	2.450	8.833	4.007	13.809	6.264	22.621	10.261
340	23.44	5.725	2.597	9.362	4.246	14.635	6.638	23.974	10.874
360	24.82	6.049	2.744	9.890	4.486	15.461	7.013	25.327	11.488
380	26.20	6.372	2.890	10.419	4.726	16.288	7.388	26.681	12.102
400	27.58	6.695	3.037	10.947	4.966	17.114	7.763	28.034	12.716
420	28.96	7.018	3.183	11.476	5.205	17.940	8.137	29.388	13.330
440	30.34	7.341	3.330	12.005	5.445	18.766	8.512	30.741	13.944
460	31.72	7.665	3.477	12.533	5.685	19.593	8.887	32.095	14.558
480	33.09	7.988	3.623	13.062	5.925	20.419	9.262	33.448	15.172
500	34.47	8.311	3.770	13.590	6.164	21.245	9.637	34.801	15.786
600	41.37	9.927	4.503	16.233	7.363	25.376	11.510	41.569	18.855
700	48.26	11.543	5.236	18.875	8.562	29.507	13.384	48.336	21.925
800	55.16	13.159	5.969	21.518	9.760	33.638	15.258	55.103	24.994
900	62.05	14.776	6.702	24.160	10.959	37.769	17.132	61.870	28.064
1000	68.95	16.392	7.435	26.803	12.158	41.900	19.006	68.637	31.133
1100	75.84	18.008	8.168	29.446	13.356	46.031	20.879	75.404	34.203
1200	82.74	19.624	8.901	32.088	14.555	50.162	22.753	82.171	37.272
1300	89.63	21.240	9.634	34.731	15.754	54.293	24.627	88.938	40.342
1400	96.53	22.856	10.367	37.373	16.952	58.425	26.501	95.706	43.411
1500	103.42	24.472	11.100	40.016	18.151	62.556	28.375	102.473	46.481
1750	120.66	28.917	13.117	47.284	21.448	73.917	33.528	121.084	54.923
2000	137.90	33.614	15.247	54.964	24.931	85.923	38.974	140.751	63.844
2250	155.13	38.610	17.513	63.134	28.637	98.695	44.767	161.673	73.334
2500	172.37	44.020	19.967	71.980	32.649	112.524	51.040	184.326	83.609
2750	189.61	0.022	22.690	81.794	37.101	127.867	57.999	209.460	95.009
3000	206.84	56.917	25.817	93.069	42.215	145.492	65.994	238.331	108.105
3200	220.63	63.428	28.770	103.714	47.044	162.133	73.542	265.591	120.470
3250	224.08	52.754	23.929	86.261	39.127	134.849	61.167	220.898	100.197
3500	241.32	56.794	25.761	92.867	42.124	145.177	65.851	237.815	107.871
3750	258.55	60.834	27.594	99.474	45.121	155.505	70.536	254.733	115.545
4000	275.79	64.875	29.427	106.080	48.117	-	-	-	-
4250	293.03	68.915	31.259	112.687	51.114	-	-	-	-
4500	310.26	72.955	33.092	119.293	54.111	-	-	-	-
4750	327.50	76.995	34.925	125.900	57.107	-	-	-	-
5000	344.74	81.036	36.757	132.506	60.104	-	-	-	-
5250	361.97	85.076	38.590	139.113	63.100	-	-	-	-
5500	379.21	89.116	40.422	145.719	66.097	-	-	-	-
5750	396.45	93.156	42.255	152.326	69.094	-	-	-	-
6000	413.69	97.197	44.088	158.932	72.090	-	-	-	-
6250	430.92	101.237	45.920	165.538	75.087	-	-	-	-

1. The Napier correction factor has been supplied in the table for set pressures between 1500 psig and 3200 psig.
2. For set pressures above 3100 psig, steam is considered supercritical, and the displayed flow capacity should be multiplied by the appropriate supercritical steam correction factor.

ANDERSON GREENWOOD SERIES 5200 PILOT OPERATED PRESSURE RELIEF VALVES

CAPACITIES

CAPACITY TABLES - SECTION I STEAM (Continued)

Orifice designation		K		L		M		N		P	
		in ²	cm ²	in ²	cm ²	in ²	cm ²	in ²	cm ²	in ²	cm ²
Orifice area		1.838	11.860	2.853	18.410	3.600	23.230	4.340	28.000	6.380	41.160
Set pressure											
Orifice capacity											
psig	barg	lbs/hr	kg/hr	lbs/hr	kg/hr	lbs/hr	kg/hr	lbs/hr	kg/hr	lbs/hr	kg/hr
15	1.03	2.976	1.350	4.617	2.094	5.827	2.643	7.024	3.186	10.329	4.685
20	1.38	3.445	1.563	5.345	2.425	6.746	3.060	8.131	3.688	11.958	5.424
30	2.07	4.384	1.988	6.802	3.085	8.584	3.894	10.347	4.693	15.216	6.902
40	2.76	5.322	2.414	8.258	3.746	10.422	4.727	12.563	5.698	18.475	8.380
50	3.45	6.261	2.840	9.714	4.406	12.260	5.561	14.778	6.703	21.733	9.858
60	4.14	7.200	3.266	11.171	5.067	14.098	6.395	16.994	7.708	24.991	11.336
70	4.83	8.148	3.696	12.642	5.734	15.954	7.237	19.232	8.723	28.282	12.829
80	5.52	9.115	4.134	14.142	6.415	17.848	8.096	21.514	9.758	31.638	14.351
90	6.21	10.082	4.573	15.642	7.095	19.741	8.954	23.796	10.794	34.995	15.873
100	6.89	11.049	5.012	17.142	7.776	21.634	9.813	26.078	11.829	38.351	17.396
120	8.27	12.982	5.889	20.143	9.137	25.421	11.531	30.642	13.899	45.063	20.440
140	9.65	14.916	6.766	23.143	10.497	29.207	13.248	35.206	15.969	51.775	23.485
160	11.03	16.850	7.643	26.143	11.858	32.993	14.966	39.771	18.040	58.487	26.529
180	12.41	18.783	8.520	29.143	13.219	36.780	16.683	44.335	20.110	65.199	29.574
200	13.79	20.717	9.397	32.144	14.580	40.566	18.401	48.899	22.180	71.911	32.619
220	15.17	22.651	10.274	35.144	15.941	44.353	20.118	53.463	24.251	78.624	35.663
240	16.55	24.585	11.151	38.144	17.302	48.139	21.836	58.027	26.321	85.336	38.708
260	17.93	26.518	12.029	41.144	18.663	51.926	23.553	62.592	28.391	92.048	41.752
280	19.31	28.452	12.906	44.145	20.024	55.712	25.271	67.156	30.461	98.760	44.797
300	20.68	30.386	13.783	47.145	21.385	59.498	26.988	71.720	32.532	105.472	47.841
320	22.06	32.320	14.660	50.145	22.745	63.285	28.705	76.284	34.602	112.185	50.886
340	23.44	34.253	15.537	53.145	24.106	67.071	30.423	80.848	36.672	118.897	53.931
360	24.82	36.187	16.414	56.146	25.467	70.858	32.140	85.413	38.743	125.609	56.975
380	26.20	38.121	17.291	59.146	26.828	74.644	33.858	89.977	40.813	132.321	60.020
400	27.58	40.055	18.168	62.146	28.189	78.430	35.575	94.541	42.883	139.033	63.064
420	28.96	41.988	19.046	65.147	29.550	82.217	37.293	99.105	44.953	145.745	66.109
440	30.34	43.922	19.923	68.147	30.911	86.003	39.010	103.669	47.024	152.458	69.154
460	31.72	45.856	20.800	71.147	32.272	89.790	40.728	108.234	49.094	159.170	72.198
480	33.09	47.789	21.677	74.147	33.633	93.576	42.445	112.798	51.164	165.882	75.243
500	34.47	49.723	22.554	77.148	34.994	97.363	44.163	117.362	53.235	172.594	78.287
600	41.37	59.392	26.940	92.149	41.798	116.295	52.750	140.183	63.586	206.155	93.510
700	48.26	69.061	31.325	107.150	48.603	135.227	61.338	163.004	73.937	239.716	108.733
800	55.16	78.729	35.711	122.152	55.407	154.159	69.925	185.825	84.289	273.277	123.956
900	62.05	88.398	40.097	137.153	62.212	173.091	78.513	208.646	94.640	306.838	139.179
1000	68.95	98.067	44.482	152.154	69.016	192.023	87.100	231.467	104.992	340.398	154.402
1100	75.84	107.735	48.868	167.156	75.820	210.955	95.688	254.288	115.343	373.959	169.625
1200	82.74	117.404	53.253	182.157	82.625	229.888	104.275	277.109	125.695	407.520	184.848
1300	89.63	127.072	57.639	197.158	89.429	248.820	112.863	299.930	136.046	441.081	200.071
1400	96.53	136.741	62.025	212.160	96.234	267.752	121.450	322.751	146.398	474.642	215.294
1500	103.42	146.410	66.410	227.161	103.038	286.684	130.038	345.572	156.749	508.203	230.517
1750	120.66	173.002	78.472	268.419	121.753	338.753	153.656	-	-	-	-
2000	137.90	201.101	91.218	312.017	141.528	393.774	178.613	-	-	-	-
2250	155.13	230.994	104.777	358.396	162.566	452.307	205.163	-	-	-	-
2500	172.37	-	-	-	-	-	-	-	-	-	-
2750	189.61	-	-	-	-	-	-	-	-	-	-
3000	206.84	-	-	-	-	-	-	-	-	-	-
3200	220.63	-	-	-	-	-	-	-	-	-	-
3250	224.08	-	-	-	-	-	-	-	-	-	-
3500	241.32	-	-	-	-	-	-	-	-	-	-
3750	258.55	-	-	-	-	-	-	-	-	-	-
4000	275.79	-	-	-	-	-	-	-	-	-	-
4250	293.03	-	-	-	-	-	-	-	-	-	-
4500	310.26	-	-	-	-	-	-	-	-	-	-
4750	327.50	-	-	-	-	-	-	-	-	-	-
5000	344.74	-	-	-	-	-	-	-	-	-	-
5250	361.97	-	-	-	-	-	-	-	-	-	-
5500	379.21	-	-	-	-	-	-	-	-	-	-
5750	396.45	-	-	-	-	-	-	-	-	-	-
6000	413.69	-	-	-	-	-	-	-	-	-	-
6250	430.92	-	-	-	-	-	-	-	-	-	-

1. The Napier correction factor has been supplied in the table for set pressures between 1500 psig and 3200 psig.
2. For set pressures above 3100 psig, steam is considered supercritical, and the displayed flow capacity should be multiplied by the appropriate supercritical steam correction factor.

ANDERSON GREENWOOD SERIES 5200 PILOT OPERATED PRESSURE RELIEF VALVES

CAPACITIES

CAPACITY TABLES - SECTION I STEAM (Continued)

Orifice designation		Q		R		T	
Orifice area		in ²	cm ²	in ²	cm ²	in ²	cm ²
Set pressure		11.050	71.290	16.000	103.226	26.000	167.742
Orifice capacity							
psig	barg	lbs/hr	kg/hr	lbs/hr	kg/hr	lbs/hr	kg/hr
15	1.03	17 877	8 109	25 894	11 745	42 083	19 088
20	1.38	20 697	9 388	29 978	13 598	48 720	22 099
30	2.07	26 336	11 946	38 147	17 303	61 995	28 121
40	2.76	31 976	14 504	46 315	21 008	75 271	34 142
50	3.45	37 615	17 062	54 484	24 713	88 546	40 164
60	4.14	43 255	19 620	62 652	28 418	101 821	46 185
70	4.83	48 951	22 204	70 902	32 161	115 229	52 267
80	5.52	54 759	24 838	79 316	35 977	128 903	58 469
90	6.21	60 568	27 473	87 729	39 793	142 576	64 671
100	6.89	66 376	30 108	96 143	43 610	156 250	70 874
120	8.27	77 994	35 377	112 970	51 242	183 597	83 278
140	9.65	89 611	40 647	129 797	58 875	210 944	95 682
160	11.03	101 228	45 916	146 624	66 507	238 291	108 087
180	12.41	112 846	51 186	163 451	74 140	265 638	120 491
200	13.79	124 463	56 455	180 278	81 773	292 985	132 896
220	15.17	136 080	61 725	197 105	89 405	320 332	145 300
240	16.55	147 698	66 994	213 932	97 038	347 679	157 704
260	17.93	159 315	72 264	230 759	104 670	375 026	170 109
280	19.31	170 932	77 533	247 586	112 303	402 373	182 513
300	20.68	182 549	82 803	264 413	119 936	429 720	194 918
320	22.06	194 167	88 072	281 240	127 568	457 067	207 322
340	23.44	205 784	93 342	298 067	135 201	484 414	219 726
360	24.82	217 401	98 612	314 894	142 833	511 761	232 131
380	26.20	229 019	103 881	331 721	150 466	539 108	244 535
400	27.58	240 636	109 151	348 548	158 098	566 455	256 940
420	28.96	252 253	114 420	365 375	165 731	593 802	269 344
440	30.34	263 871	119 690	382 202	173 364	621 149	281 748
460	31.72	275 488	124 959	399 029	180 996	648 496	294 153
480	33.09	287 105	130 229	415 856	188 629	675 843	306 557
500	34.47	298 722	135 498	432 683	196 261	703 190	318 962
600	41.37	356 809	161 846	516 818	234 424	839 926	380 984
700	48.26	414 895	188 193	600 953	272 587	976 661	443 006
800	55.16	472 982	214 541	685 088	310 750	1 113 396	505 028
900	62.05	531 068	240 888	769 223	348 913	1 250 131	567 049
1000	68.95	589 155	267 236	853 358	387 076	1 386 866	629 071
1100	75.84	647 241	293 583	937 493	425 239	1 523 601	691 093
1200	82.74	705 328	319 931	1 021 628	463 402	1 660 337	753 115
1300	89.63	763 414	346 279	1 105 763	501 565	1 797 072	815 137
1400	96.53	821 501	372 626	1 189 898	539 728	1 933 807	877 159
1500	103.42	879 587	398 974	1 274 033	577 891	2 070 542	939 181
1750	120.66	-	-	-	-	-	-
2000	137.90	-	-	-	-	-	-
2250	155.13	-	-	-	-	-	-
2500	172.37	-	-	-	-	-	-
2750	189.61	-	-	-	-	-	-
3000	206.84	-	-	-	-	-	-
3200	220.63	-	-	-	-	-	-
3250	224.08	-	-	-	-	-	-
3500	241.32	-	-	-	-	-	-
3750	258.55	-	-	-	-	-	-
4000	275.79	-	-	-	-	-	-
4250	293.03	-	-	-	-	-	-
4500	310.26	-	-	-	-	-	-
4750	327.50	-	-	-	-	-	-
5000	344.74	-	-	-	-	-	-
5250	361.97	-	-	-	-	-	-
5500	379.21	-	-	-	-	-	-
5750	396.45	-	-	-	-	-	-
6000	413.69	-	-	-	-	-	-
6250	430.92	-	-	-	-	-	-

ANDERSON GREENWOOD SERIES 5200 PILOT OPERATED PRESSURE RELIEF VALVES

CAPACITIES

CAPACITY TABLES - SECTION I WATER

Orifice designation		F		G		H		J		K		L	
Orifice area		in ²	cm ²	in ²	cm ²	in ²	cm ²	in ²	cm ²	in ²	cm ²	in ²	cm ²
Set pressure		0.307	1.981	0.503	3.245	0.785	5.065	1.287	8.303	1.838	11.860	2.853	18.410
Orifice capacity													
psig	barg	gpm	L/min	gpm	L/min	gpm	L/min	gpm	L/min	gpm	L/min	gpm	L/min
15	1.03	37	139	60	227	94	355	153	581	219	830	340	1.288
20	1.38	42	158	68	258	107	403	175	661	249	944	387	1.465
30	2.07	50	190	82	311	129	486	211	797	301	1.139	467	1.766
40	2.76	58	218	94	356	147	557	241	913	345	1.304	535	2.024
50	3.45	64	243	105	397	164	620	268	1.016	383	1.451	595	2.252
60	4.14	70	265	114	433	179	677	293	1.109	419	1.585	650	2.459
70	4.83	75	286	123	467	193	730	316	1.196	451	1.709	700	2.652
80	5.52	81	305	132	499	206	781	338	1.279	483	1.827	749	2.835
90	6.21	86	324	140	530	219	828	358	1.356	512	1.938	794	3.007
100	6.89	90	341	147	558	231	873	378	1.430	540	2.043	837	3.169
120	8.27	99	374	162	612	253	956	414	1.566	591	2.238	917	3.472
140	9.65	107	404	175	661	273	1.033	447	1.692	638	2.417	991	3.750
160	11.03	114	432	187	706	292	1.104	478	1.808	683	2.584	1.059	4.009
180	12.41	121	458	198	749	309	1.171	507	1.918	724	2.740	1.123	4.252
200	13.79	128	483	209	790	326	1.234	534	2.022	763	2.889	1.184	4.482
220	15.17	134	506	219	828	342	1.294	560	2.121	800	3.030	1.242	4.701
240	16.55	140	529	228	865	357	1.352	585	2.215	836	3.164	1.297	4.910
260	17.93	145	551	238	900	372	1.407	609	2.305	870	3.294	1.350	5.110
280	19.31	151	571	247	934	386	1.460	632	2.392	903	3.418	1.401	5.303
300	20.68	156	591	255	967	399	1.512	654	2.476	935	3.538	1.450	5.489
320	22.06	161	611	264	999	412	1.561	676	2.557	965	3.654	1.498	5.669
340	23.44	166	630	272	1.029	425	1.609	696	2.636	995	3.766	1.544	5.844
360	24.82	171	648	280	1.059	437	1.656	717	2.713	1.024	3.876	1.589	6.013
380	26.20	176	666	287	1.088	449	1.701	736	2.787	1.052	3.982	1.632	6.178
400	27.58	180	683	295	1.117	461	1.745	755	2.859	1.079	4.085	1.674	6.338
420	28.96	185	700	302	1.144	472	1.789	774	2.930	1.106	4.186	1.716	6.495
440	30.34	189	716	309	1.171	484	1.831	792	2.999	1.132	4.285	1.756	6.648
460	31.72	193	732	316	1.197	494	1.872	810	3.066	1.157	4.381	1.796	6.797
480	33.09	198	748	323	1.223	505	1.912	827	3.132	1.182	4.475	1.834	6.943
500	34.47	202	763	330	1.248	516	1.952	844	3.197	1.207	4.567	1.872	7.087
600	41.37	221	836	361	1.367	565	2.138	925	3.502	1.322	5.003	2.051	7.763
700	48.26	239	903	390	1.477	610	2.309	999	3.782	1.428	5.404	2.215	8.385
800	55.16	255	966	417	1.579	652	2.468	1.068	4.044	1.526	5.777	2.368	8.964
900	62.05	271	1.024	442	1.675	692	2.618	1.133	4.289	1.619	6.128	2.512	9.508
1000	68.95	285	1.080	466	1.765	729	2.760	1.194	4.521	1.706	6.459	2.648	10.022
1100	75.84	299	1.132	489	1.852	765	2.895	1.253	4.742	1.790	6.775	2.777	10.511
1200	82.74	312	1.183	511	1.934	799	3.023	1.308	4.952	1.869	7.076	2.900	10.979
1300	89.63	325	1.231	532	2.013	831	3.147	1.362	5.155	1.946	7.365	3.019	11.427
1400	96.53	337	1.277	552	2.089	863	3.265	1.413	5.349	2.019	7.643	3.133	11.858
1500	103.42	349	1.322	571	2.162	893	3.380	1.463	5.537	2.090	7.911	3.243	12.274
1750	120.66	377	1.428	617	2.335	964	3.651	1.580	5.981	2.257	8.545	3.502	13.258
2000	137.90	403	1.527	660	2.497	1.031	3.903	1.689	6.394	2.413	9.135	3.744	14.173
2250	155.13	428	1.620	700	2.648	1.094	4.140	1.791	6.781	2.560	9.689	3.971	15.033
2500	172.37	451	1.707	737	2.791	1.153	4.364	1.888	7.148	-	-	-	-
2750	189.61	473	1.790	773	2.928	1.209	4.577	1.981	7.497	-	-	-	-
3000	206.84	494	1.870	808	3.058	1.263	4.780	2.069	7.830	-	-	-	-
3200	220.63	510	1.931	834	3.158	1.304	4.937	2.136	8.087	-	-	-	-
3250	224.08	514	1.946	841	3.183	1.314	4.975	2.153	8.150	-	-	-	-
3500	241.32	534	2.020	873	3.303	1.364	5.163	2.234	8.458	-	-	-	-
3750	258.55	552	2.091	903	3.419	1.412	5.344	2.313	8.755	-	-	-	-
4000	275.79	570	2.159	933	3.531	-	-	-	-	-	-	-	-
4250	293.03	588	2.226	961	3.640	-	-	-	-	-	-	-	-
4500	310.26	605	2.290	989	3.745	-	-	-	-	-	-	-	-
4750	327.50	622	2.353	1.016	3.848	-	-	-	-	-	-	-	-
5000	344.74	638	2.414	1.043	3.948	-	-	-	-	-	-	-	-
5250	361.97	654	2.474	1.069	4.045	-	-	-	-	-	-	-	-
5500	379.21	669	2.532	1.094	4.140	-	-	-	-	-	-	-	-
5750	396.45	684	2.589	1.118	4.233	-	-	-	-	-	-	-	-
6000	413.69	699	2.645	1.142	4.324	-	-	-	-	-	-	-	-
6250	430.92	713	2.699	1.166	4.414	-	-	-	-	-	-	-	-

ANDERSON GREENWOOD SERIES 5200 PILOT OPERATED PRESSURE RELIEF VALVES

CAPACITIES

CAPACITY TABLES - SECTION I WATER (Continued)

Orifice designation		M		N		P		Q		R		T	
Orifice area		in ²	cm ²	in ²	cm ²	in ²	cm ²	in ²	cm ²	in ²	cm ²	in ²	cm ²
Set pressure		3.600	23.230	4.340	28.000	6.380	41.160	11.050	71.290	16.000	103.226	26.000	167.742
Orifice capacity													
psig	barg	gpm	L/min	gpm	L/min	gpm	L/min	gpm	L/min	gpm	L/min	gpm	L/min
15	1.03	429	1.625	517	1.959	761	2.880	1 317	4 985	1 908	7 221	3 100	11 736
20	1.38	488	1.848	589	2.228	866	3.277	1 498	5 671	2 170	8 215	3 527	13 350
30	2.07	589	2.229	710	2.687	1.044	3.952	1 807	6 840	2 617	9 907	4 254	16 101
40	2.76	675	2.554	813	3.079	1.196	4.528	2 070	7 836	2 998	11 350	4 873	18 446
50	3.45	751	2.842	905	3.426	1.331	5.038	2 303	8 719	3 336	12 629	5 422	20 525
60	4.14	820	3.103	988	3.741	1.453	5.501	2 515	9 521	3 643	13 790	5 921	22 412
70	4.83	884	3.346	1.066	4.034	1.567	5.932	2 712	10 267	3 929	14 871	6 385	24 169
80	5.52	945	3.577	1.139	4.312	1.675	6.342	2 900	10 976	4 200	15 898	6 826	25 837
90	6.21	1.002	3.794	1.208	4.574	1.777	6.726	3 075	11 642	4 455	16 862	7 240	27 405
100	6.89	1.057	4.000	1.274	4.821	1.873	7.090	3 242	12 272	4 696	17 775	7 631	28 887
120	8.27	1.157	4.381	1.395	5.281	2.052	7.767	3 551	13 443	5 144	19 471	8 360	31 644
140	9.65	1.250	4.732	1.507	5.705	2.216	8.389	3 836	14 520	5 556	21 031	9 029	34 180
160	11.03	1.337	5.059	1.611	6.098	2.369	8.968	4 101	15 522	5 939	22 483	9 653	36 540
180	12.41	1.418	5.366	1.709	6.468	2.513	9.512	4 349	16 464	6 300	23 847	10 238	38 756
200	13.79	1.494	5.656	1.801	6.818	2.649	10.027	4 585	17 355	6 641	25 137	10 792	40 852
220	15.17	1.567	5.932	1.889	7.151	2.778	10.516	4 808	18 202	6 965	26 364	11 319	42 846
240	16.55	1.637	6.196	1.973	7.469	2.902	10.984	5 022	19 011	7 274	27 536	11 822	44 752
260	17.93	1.704	6.449	2.054	7.774	3.020	11.433	5 227	19 787	7 571	28 661	12 305	46 579
280	19.31	1.768	6.693	2.131	8.067	3.134	11.864	5 425	20 534	7 857	29 743	12 769	48 337
300	20.68	1.830	6.928	2.206	8.351	3.244	12.281	5 615	21 255	8 133	30 787	13 218	50 034
320	22.06	1.890	7.155	2.278	8.624	3.351	12.683	5 799	21 952	8 400	31 796	13 651	51 675
340	23.44	1.948	7.375	2.348	8.890	3.454	13.074	5 978	22 628	8 658	32 775	14 071	53 265
360	24.82	2.005	7.589	2.417	9.148	3.554	13.453	6 151	23 284	8 909	33 725	14 479	54 809
380	26.20	2.060	7.797	2.483	9.398	3.651	13.821	6 319	23 922	9 153	34 649	14 876	56 311
400	27.58	2.113	7.999	2.547	9.642	3.746	14.180	6 484	24 543	9 391	35 549	15 262	57 774
420	28.96	2.165	8.197	2.610	9.881	3.839	14.531	6 644	25 149	9 623	36 427	15 639	59 201
440	30.34	2.216	8.390	2.672	10.113	3.929	14.872	6 800	25 741	9 849	37 284	16 007	60 594
460	31.72	2.266	8.578	2.732	10.340	4.017	15.207	6 953	26 319	10 071	38 122	16 367	61 956
480	33.09	2.315	8.763	2.790	10.563	4.104	15.534	7 102	26 886	10 287	38 942	16 719	63 288
500	34.47	2.363	8.944	2.848	10.781	4.188	15.854	7 249	27 440	10 500	39 745	17 064	64 593
600	41.37	2.588	9.797	3.120	11.810	4.588	17.367	7 941	30 059	11 502	43 539	18 692	70 759
700	48.26	2.795	10.582	3.370	12.756	4.956	18.759	8 577	32 467	12 423	47 027	20 190	76 428
800	55.16	2.989	11.313	3.602	13.637	5.298	20.054	9 169	34 709	13 281	50 274	21 584	81 705
900	62.05	3.170	11.999	3.821	14.464	5.619	21.270	9 725	36 815	14 087	53 324	22 893	86 661
1000	68.95	3.341	12.648	4.028	15.246	5.923	22.421	10 251	38 806	14 849	56 208	24 132	91 349
1100	75.84	3.504	13.265	4.224	15.990	6.212	23.515	10 752	40 700	15 573	58 952	25 310	95 808
1200	82.74	3.660	13.855	4.412	16.701	6.488	24.561	11 230	42 510	16 266	61 573	26 435	100 068
1300	89.63	3.810	14.421	4.592	17.383	6.753	25.564	11 688	44 246	16 930	64 087	27 515	104 154
1400	96.53	3.953	14.965	4.766	18.039	7.008	26.529	12 130	45 916	17 569	66 506	28 553	108 085
1500	103.42	4.092	15.491	4.933	18.673	7.254	27.460	12 555	47 527	18 186	68 841	29 555	111 879
1750	120.66	4.420	16.732	-	-	-	-	-	-	-	-	-	-
2000	137.90	4.725	17.887	-	-	-	-	-	-	-	-	-	-
2250	155.13	5.012	18.972	-	-	-	-	-	-	-	-	-	-
2500	172.37	-	-	-	-	-	-	-	-	-	-	-	-
2750	189.61	-	-	-	-	-	-	-	-	-	-	-	-
3000	206.84	-	-	-	-	-	-	-	-	-	-	-	-
3200	220.63	-	-	-	-	-	-	-	-	-	-	-	-
3250	224.08	-	-	-	-	-	-	-	-	-	-	-	-
3500	241.32	-	-	-	-	-	-	-	-	-	-	-	-
3750	258.55	-	-	-	-	-	-	-	-	-	-	-	-
4000	275.79	-	-	-	-	-	-	-	-	-	-	-	-
4250	293.03	-	-	-	-	-	-	-	-	-	-	-	-
4500	310.26	-	-	-	-	-	-	-	-	-	-	-	-
4750	327.50	-	-	-	-	-	-	-	-	-	-	-	-
5000	344.74	-	-	-	-	-	-	-	-	-	-	-	-
5250	361.97	-	-	-	-	-	-	-	-	-	-	-	-
5500	379.21	-	-	-	-	-	-	-	-	-	-	-	-
5750	396.45	-	-	-	-	-	-	-	-	-	-	-	-
6000	413.69	-	-	-	-	-	-	-	-	-	-	-	-
6250	430.92	-	-	-	-	-	-	-	-	-	-	-	-

ANDERSON GREENWOOD SERIES 5200 PILOT OPERATED PRESSURE RELIEF VALVES

CAPACITIES

CAPACITY TABLES - SECTION VIII STEAM

Orifice designation		F		G		H		J		K		L	
		in ²	cm ²	in ²	cm ²	in ²	cm ²	in ²	in ²	in ²	cm ²	in ²	cm ²
Orifice area		0.307	1.981	0.503	3.245	0.785	5.065	1.287	8.303	1.838	11.860	2.853	18.410
Set pressure		Orifice capacity											
psig	barg	lbs/hr	kg/hr	lbs/hr	kg/hr	lbs/hr	kg/hr	lbs/hr	kg/hr	lbs/hr	kg/hr	lbs/hr	kg/hr
15	1.03	513	233	839	381	1.312	595	2.148	974	3.070	1.392	4.763	2.160
20	1.38	592	268	967	439	1.512	686	2.477	1.124	3.539	1.605	5.491	2.491
30	2.07	748	339	1.224	555	1.913	868	3.134	1.422	4.478	2.031	6.947	3.151
40	2.76	921	418	1.506	683	2.354	1.068	3.857	1.749	5.510	2.499	8.549	3.878
50	3.45	1.094	496	1.788	811	2.795	1.268	4.579	2.077	6.543	2.968	10.151	4.605
60	4.14	1.266	574	2.070	939	3.237	1.468	5.302	2.405	7.575	3.436	11.753	5.331
70	4.83	1.439	653	2.353	1.067	3.678	1.668	6.025	2.733	8.608	3.904	13.356	6.058
80	5.52	1.611	731	2.635	1.195	4.119	1.868	6.747	3.061	9.640	4.373	14.958	6.785
90	6.21	1.784	809	2.917	1.323	4.560	2.068	7.470	3.388	10.673	4.841	16.560	7.511
100	6.89	1.957	887	3.199	1.451	5.001	2.269	8.193	3.716	11.706	5.310	18.162	8.238
120	8.27	2.302	1.044	3.764	1.707	5.884	2.669	9.638	4.372	13.771	6.246	21.366	9.691
140	9.65	2.647	1.201	4.328	1.963	6.766	3.069	11.084	5.027	15.836	7.183	24.570	11.145
160	11.03	2.992	1.357	4.893	2.219	7.648	3.469	12.529	5.683	17.901	8.120	27.774	12.598
180	12.41	3.337	1.514	5.457	2.475	8.531	3.870	13.974	6.339	19.966	9.057	30.978	14.052
200	13.79	3.683	1.670	6.021	2.731	9.413	4.270	15.420	6.994	22.031	9.993	34.183	15.505
220	15.17	4.028	1.827	6.586	2.987	10.296	4.670	16.865	7.650	24.097	10.930	37.387	16.958
240	16.55	4.373	1.984	7.150	3.243	11.178	5.070	18.311	8.306	26.162	11.867	40.591	18.412
260	17.93	4.718	2.140	7.715	3.499	12.060	5.470	19.756	8.961	28.227	12.803	43.795	19.865
280	19.31	5.063	2.297	8.279	3.755	12.943	5.871	21.201	9.617	30.292	13.740	46.999	21.319
300	20.68	5.408	2.453	8.844	4.011	13.825	6.271	22.647	10.272	32.357	14.677	50.203	22.772
320	22.06	5.754	2.610	9.408	4.267	14.707	6.671	24.092	10.928	34.422	15.614	53.408	24.225
340	23.44	6.099	2.766	9.973	4.523	15.590	7.071	25.538	11.584	36.487	16.550	56.612	25.679
360	24.82	6.444	2.923	10.537	4.779	16.472	7.472	26.983	12.239	38.553	17.487	59.816	27.132
380	26.20	6.789	3.080	11.101	5.036	17.355	7.872	28.429	12.895	40.618	18.424	63.020	28.585
400	27.58	7.134	3.236	11.666	5.292	18.237	8.272	29.874	13.551	42.683	19.361	66.224	30.039
420	28.96	7.480	3.393	12.230	5.548	19.119	8.672	31.319	14.206	44.748	20.297	69.428	31.492
440	30.34	7.825	3.549	12.795	5.804	20.002	9.073	32.765	14.862	46.813	21.234	72.633	32.946
460	31.72	8.170	3.706	13.359	6.060	20.884	9.473	34.210	15.517	48.878	22.171	75.837	34.399
480	33.09	8.515	3.862	13.924	6.316	21.766	9.873	35.656	16.173	50.944	23.108	79.041	35.852
500	34.47	8.860	4.019	14.488	6.572	22.649	10.273	37.101	16.829	53.009	24.044	82.245	37.306
600	41.37	10.586	4.802	17.310	7.852	27.061	12.274	44.328	20.107	63.334	28.728	98.266	44.573
700	48.26	12.312	5.585	20.132	9.132	31.472	14.276	51.555	23.385	73.660	33.412	114.287	51.840
800	55.16	14.038	6.368	22.955	10.412	35.884	16.277	58.782	26.663	83.986	38.095	130.308	59.107
900	62.05	15.764	7.150	25.777	11.692	40.296	18.278	66.009	29.941	94.312	42.779	146.328	66.373
1000	68.95	17.490	7.933	28.599	12.972	44.708	20.279	73.236	33.219	104.637	47.463	162.349	73.640
1100	75.84	19.216	8.716	31.421	14.252	49.120	22.280	80.463	36.497	114.963	52.146	178.370	80.907
1200	82.74	20.942	9.499	34.243	15.532	53.531	24.281	87.690	39.776	125.289	56.830	194.391	88.174
1300	89.63	22.668	10.282	37.065	16.813	57.943	26.283	94.917	43.054	135.615	61.514	210.412	95.441
1400	96.53	24.394	11.065	39.888	18.093	62.355	28.284	102.144	46.332	145.940	66.197	226.433	102.708
1500	103.42	26.120	11.848	42.710	19.373	66.767	30.285	109.371	49.610	156.266	70.881	242.453	109.975
1750	120.66	31.119	14.116	50.885	23.081	79.547	36.082	130.307	59.106	186.178	84.449	288.863	131.026
2000	137.90	36.287	16.459	59.335	26.914	92.757	42.074	151.945	68.921	217.094	98.472	336.831	152.784
2250	155.13	41.861	18.988	68.449	31.048	107.004	48.536	175.283	79.507	250.439	113.597	388.567	176.251
2500	172.37	48.020	21.781	78.520	35.616	122.748	55.678	201.074	91.206	-	-	-	-
2750	189.61	55.069	24.979	90.046	40.844	140.767	63.851	230.591	104.594	-	-	-	-
3000	206.84	63.566	28.833	103.940	47.146	162.487	73.703	266.170	120.733	-	-	-	-
3200	220.63	72.140	32.722	117.960	53.506	184.403	83.644	302.072	137.017	-	-	-	-

ANDERSON GREENWOOD SERIES 5200 PILOT OPERATED PRESSURE RELIEF VALVES

CAPACITIES

CAPACITY TABLES - SECTION VIII STEAM (Continued)

Orifice designation		M		N		P		Q		R		T	
		in ²	cm ²	in ²	cm ²	in ²	cm ²	in ²	cm ²	in ²	cm ²	in ²	cm ²
Orifice area		3.600	23.230	4.340	28.00	6.380	41.160	11.050	71.290	16.000	103.226	26.000	167.742
Set pressure		Orifice capacity											
psig	barg	lbs/hr	kg/hr	lbs/hr	kg/hr	lbs/hr	kg/hr	lbs/hr	kg/hr	lbs/hr	kg/hr	lbs/hr	kg/hr
15	1.03	6.010	2.726	7.245	3.286	10.655	4.833	18.441	8.365	26.711	12.116	43.410	19.690
20	1.38	6.930	3.143	8.353	3.789	12.284	5.572	21.261	9.644	30.795	13.968	50.048	22.701
30	2.07	8.768	3.977	10.569	4.794	15.542	7.050	26.900	12.202	38.964	17.674	63.323	28.723
40	2.76	10.789	4.894	13.006	5.899	19.126	8.676	33.104	15.016	47.949	21.749	77.926	35.347
50	3.45	12.811	5.811	15.443	7.005	22.711	10.301	39.307	17.829	56.934	25.825	92.529	41.970
60	4.14	14.833	6.728	17.880	8.110	26.295	11.927	45.510	20.643	65.919	29.901	107.131	48.594
70	4.83	16.855	7.645	20.317	9.216	29.879	13.553	51.714	23.457	74.905	33.976	121.734	55.218
80	5.52	18.877	8.562	22.755	10.321	33.463	15.179	57.917	26.271	83.890	38.052	136.337	61.841
90	6.21	20.899	9.480	25.192	11.427	37.047	16.804	64.121	29.085	92.875	42.127	150.940	68.465
100	6.89	22.921	10.397	27.629	12.532	40.631	18.430	70.324	31.898	101.861	46.203	165.542	75.089
120	8.27	26.965	12.231	32.503	14.743	47.800	21.682	82.731	37.526	119.831	54.354	194.748	88.336
140	9.65	31.008	14.065	37.378	16.954	54.968	24.933	95.138	43.154	137.802	62.506	223.954	101.584
160	11.03	35.052	15.899	42.252	19.165	62.136	28.185	107.545	48.781	155.772	70.657	253.159	114.831
180	12.41	39.096	17.734	47.127	21.376	69.305	31.436	119.951	54.409	173.743	78.808	282.365	128.078
200	13.79	43.140	19.568	52.001	23.587	76.473	34.688	132.358	60.037	191.714	86.960	311.570	141.326
220	15.17	47.183	21.402	56.875	25.798	83.642	37.939	144.765	65.664	209.684	95.111	340.776	154.573
240	16.55	51.227	23.236	61.750	28.009	90.810	41.191	157.172	71.292	227.655	103.262	369.981	167.821
260	17.93	55.271	25.070	66.624	30.220	97.978	44.442	169.579	76.920	245.625	111.414	399.187	181.068
280	19.31	59.315	26.905	71.498	32.431	105.147	47.694	181.986	82.547	263.596	119.565	428.393	194.315
300	20.68	63.358	28.739	76.373	34.642	112.315	50.945	194.392	88.175	281.567	127.716	457.598	207.563
320	22.06	67.402	30.573	81.247	36.853	119.483	54.197	206.799	93.802	299.537	135.868	486.804	220.810
340	23.44	71.446	32.407	86.122	39.064	126.652	57.448	219.206	99.430	317.508	144.019	516.009	234.058
360	24.82	75.490	34.241	90.996	41.275	133.820	60.700	231.613	105.058	335.478	152.170	545.215	247.305
380	26.20	79.533	36.076	95.870	43.486	140.988	63.951	244.020	110.685	353.449	160.322	574.420	260.553
400	27.58	83.577	37.910	100.745	45.697	148.157	67.203	256.426	116.313	371.419	168.473	603.626	273.800
420	28.96	87.621	39.744	105.619	47.908	155.325	70.454	268.833	121.941	389.390	176.624	632.832	287.047
440	30.34	91.665	41.578	110.494	50.119	162.493	73.706	281.240	127.568	407.361	184.776	662.037	300.295
460	31.72	95.708	43.413	115.368	52.330	169.662	76.957	293.647	133.196	425.331	192.927	691.243	313.542
480	33.09	99.752	45.247	120.242	54.541	176.830	80.209	306.054	138.824	443.302	201.078	720.448	326.790
500	34.47	103.796	47.081	125.117	56.752	183.998	83.460	318.461	144.451	461.272	209.229	749.654	340.037
600	41.37	124.015	56.252	149.489	67.807	219.840	99.718	380.495	172.589	551.125	249.986	895.682	406.274
700	48.26	144.233	65.423	173.861	78.862	255.682	115.975	442.529	200.728	640.978	290.743	1.041.710	472.511
800	55.16	164.452	74.594	198.233	89.917	291.523	132.233	504.563	228.866	730.831	331.499	1.187.737	538.748
900	62.05	184.671	83.765	222.605	100.972	327.365	148.490	566.597	257.004	820.684	372.256	1.333.765	604.985
1000	68.95	204.890	92.936	246.977	112.027	363.207	164.748	628.631	285.142	910.537	413.012	1.479.793	671.222
1100	75.84	225.109	102.108	271.349	123.082	399.049	181.005	690.665	313.280	1.000.390	453.769	1.625.821	737.459
1200	82.74	245.327	111.279	295.721	134.137	434.890	197.263	752.699	341.418	1.090.243	494.526	1.771.849	803.696
1300	89.63	265.546	120.450	320.092	145.192	470.732	213.520	814.733	369.557	1.180.096	535.282	1.917.877	869.934
1400	96.53	285.765	129.621	344.464	156.246	506.574	229.778	876.768	397.695	1.269.949	576.039	2.063.905	936.171
1500	103.42	305.984	138.792	368.836	167.301	542.415	246.035	943.302	427.874	1.366.321	619.752	2.220.527	1.007.213
1750	120.66	364.554	165.359	-	-	-	-	-	-	-	-	-	-
2000	137.90	425.091	192.818	-	-	-	-	-	-	-	-	-	-
2250	155.13	490.384	222.434	-	-	-	-	-	-	-	-	-	-
2500	172.37	-	-	-	-	-	-	-	-	-	-	-	-
2750	189.61	-	-	-	-	-	-	-	-	-	-	-	-
3000	206.84	-	-	-	-	-	-	-	-	-	-	-	-
3200	220.63	-	-	-	-	-	-	-	-	-	-	-	-

ANDERSON GREENWOOD SERIES 5200 PILOT OPERATED PRESSURE RELIEF VALVES

SELECTION

SELECTION GUIDE

Example:	52	4	7	10	J	23	/S1
Pilot series							
52 Series 5200							
Main valve lift							
4 Full lift, API orifice							
Main valve piston type							
7 Metal seat							
Inlet flange rating, ANSI							
05 150#							
10 300#							
12 600#							
14 900#							
16 1500#							
18 2500#							
Orifice designation							
Letter API equivalent							
Inlet x outlet, inches							
Main valve materials							
/S1 WCB/WCC body, SS trim (up to 705°F [373°C])							
/S3 WC6 body, SS trim (up to 705°F [373°C])							
/SPL Special							

