



KEYSTONE SERIES GR RESILIENT SEATED BUTTERFLY VALVES

GRW/GRL

A heavy duty industrial resilient seated butterfly valve

GRW - Wafer body design

GRL - Lugged body design



FEATURES

- Wafer and lugged body design with face-to-face dimension, according to EN 558 Series 20 and API 609.
- Designed according to EN 593 and API 609.
- The seat is field replaceable and fully isolates the body and shaft from the flow.
- Primary shaft sealing exceeds the pressure rating of the valve and prevents leakage through shaft area to atmosphere.
- A secondary shaft sealing provides back-up safety.
- A molded-in O-ring in the seat for flange sealing eliminates the need for gaskets.
- Shaft seals prevent moisture penetrating into the shaft area.
- The two piece shaft allows for a thin disc and provides minimal obstruction to flow (up to DN 300/ NPS 12).
- Rounded polished disc edge gives full concentric sealing, lower torques, longer seat life and drop-tight shut-off.
- Body locating holes allow ease of installation and centering between the flanges.
- Extended body neck allows for pipe insulation.
- Top and bottom shaft bearings for optimized support and minimum friction and decreased torque.
- Top bushing absorbs actuator side thrust loads.
- All valves comply to Pressure Equipment Directive (2014/68/EU) Module B + D, CE Marking.
- Available approvals: NSF/ANSI 61, ACS, KIWA, WRAS, DVGW-G, ABS, CU-TR, DNV

GENERAL APPLICATION

Water, air, dry bulk conveying etc. These valves are for any service where a drop-tight shut-off with maximum flow area is required.

TECHNICAL DATA

Sizes:	DN 50 - 900 (NPS 2 - 36)
Pressure:	16 bar DN 50 - 300 (230 psi NPS 2 - 12) 10 bar DN 350 - 900 (150 psi NPS 14 - 36)
Reinforced seat:	16 bar DN 350 - 600 (230 psi NPS 14 - 24)
End of line:	10 bar DN 50 - 300 (150 psi NPS 2 - 12) 6 bar DN 350 - 900 (90 psi NPS 14 - 36)
Reinforced seat:	10 bar DN 350 - 600 (150 psi NPS 14 - 24)
Vacuum service:	0.4 bar (5.8 psia)
Temperature:	-40°C to +160°C (-40 °F to +320°F)
Flange accommodation:	PN 6/10/16 ASME 125/150 JIS 10K BS Table E AS4087 PN 16 AS2129 Table E

KEYSTONE SERIES GR RESILIENT SEATED BUTTERFLY VALVES

GRW/GRL

SERIES GRW/GRL
DN 50-300 (NPS 2-12)
(GRW SHOWN)

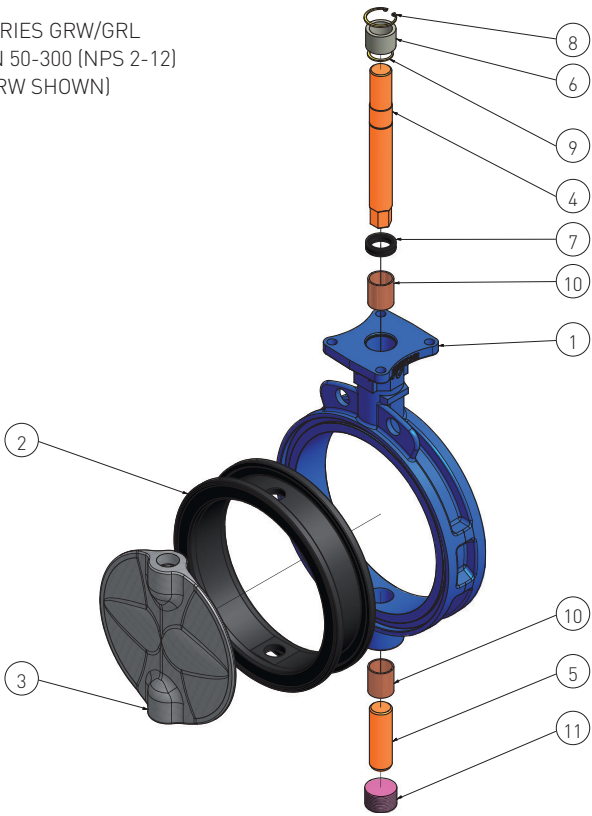

PARTS LIST

Item	Qty	Description
1	1	Body
2	1	Seat
3	1	Disc
4	1	Upper shaft
5	1	Lower shaft
6	1	Upper bushing
7	1	Packing
8	1	Body circlip
9	1	Shaft circlip
10	2	Upper and lower bearing
11	1	Plug

DN 350-900 (NPS 14-36)
(GRL SHOWN)

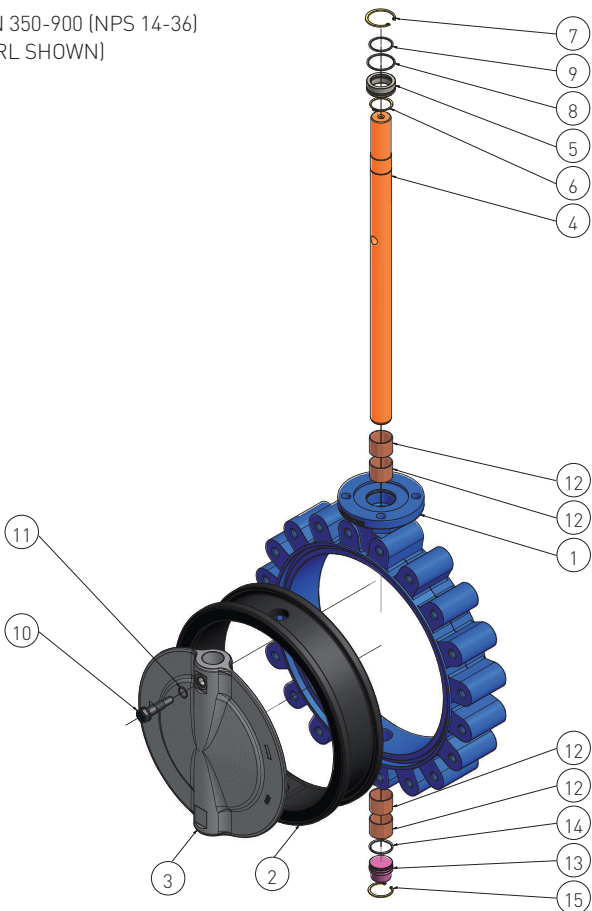

PARTS LIST

Item	Qty	Description
1	1	Body
2	1	Seat
3	1	Disc
4	1	Shaft
5	1	Bushing
6	1	Shaft circlip
7	1	Body circlip
8	1	Body O-ring
9	1	Shaft O-ring
10	1	Disc screw
11	1	Disc screw O-ring
12	4	Upper and lower bearing
13	1	Plug
14	1	Plug O-ring
15	1	Plug circlip

KEYSTONE SERIES GR RESILIENT SEATED BUTTERFLY VALVES

GRW/GRL

MATERIAL SPECIFICATION

Part name	Material	Material specification	Remark	
DN 50-300 (NPS 2-12)				
Body	Ductile iron	ASTM A536 Gr 65-45-12	(Optional)	
		ASTM A395 Gr 60-40-18		
	Carbon steel	ASTM A216 WCB		
	316 stainless steel	ASTM A351 Gr CF8M		
	Duplex	ASTM A890 Gr 4A		
Disc	Super Duplex	ASTM A890 Gr 5A		
	Duplex	ASTM A890 Gr 4A		
	316 stainless steel	ASTM A351 Gr CF8M		
	304 stainless steel	ASTM A351 Gr CF8		
	Aluminium bronze	ASTM B148 UNS C95200		
	Nickel aluminium bronze	ASTM B148 UNS C95800		
	Ductile iron NYL	ASTM A536 Gr 65-45-12		NYL = Nylon coating, max. temp. 60°C (140°F)
	Ductile iron CTD	ASTM A536 Gr 65-45-12		CTD = Nickel plating
	Shaft	316 stainless steel		ASTM A276 Gr 316
431 stainless steel		ASTM A276 Gr 431		
Super duplex		ASTM A276 UNS S32750		
Monel® K500		ASTM B865 UNS N05500		
Seat	EPDM		Food grade, NSF/ANSI 61	
	NBR		Food grade	
	HNBR			
	White NBR Fluoroelastomer (FKM)		Food grade	
Bushing	Polyester			
Packing	NBR			
Bearing	PTFE/steel			
Circlip	Stainless steel			
Plug	Carbon steel			
DN 350-900 (NPS 14-36)				
Body	Ductile iron	ASTM A536 Gr 65-45-12	(Optional)	
		ASTM A395 Gr 60-40-18		
	Carbon steel*	ASTM A216 WCB		
	316 stainless steel*	ASTM A351 Gr CF8M		
	Duplex	ASTM A890 Gr 4A		
Disc	Super Duplex	ASTM A890 Gr 5A		
	Duplex	ASTM A890 Gr 4A		
	316 stainless steel	ASTM A351 Gr CF8M		
	304 stainless steel	ASTM A351 Gr CF8		
	Aluminium bronze	ASTM B148 UNS C95200		
	Nickel aluminium bronze	ASTM B148 UNS C95800		
	Ductile iron NYL	ASTM A536 Gr 65-45-12		NYL = Nylon coating, max. temp. 60°C (140°F)
	Ductile iron CTD	ASTM A536 Gr 65-45-12		CTD = Epoxy coated, max. temp. 120°C (250°F)
	Ductile iron Ebonite			Max. temp. 100°C (212°F)
Shaft	431 stainless steel	ASTM A276 Gr 431 S43100		
	Duplex	ASTM A276 UNS S31803		
	Super duplex	ASTM A276 UNS S32750		
	Monel® K500	ASTM B865 UNS N05500		
Seat	EPDM		Food grade, NSF/ANSI 61	
	NBR		Food grade	
	HNBR			
	White NBR Fluoroelastomer (FKM)		Food grade	
Disc screw	Super duplex	ASTM A276 UNS S32750		
	Duplex	ASTM A276 UNS S31803		
Disc screw O-ring	EPDM			
	NBR			
	FKM			
Plug	Carbon steel			
Plug O-ring	NBR			
Plug circlip	Stainless steel			
Bushing	Polyester			
Shaft/Body O-ring	NBR			
Bearing	PTFE/steel			
Shaft/Body circlip	Stainless steel			

NOTES

Valves with super duplex disc will have super duplex disc screw. All other discs will have a duplex disc screw. Monel® is a registered trademark of Special Metals Corporation.

* Carbon steel and 316 stainless steel body material options are available up to and including DN 600 / NPS 24

KEYSTONE SERIES GR RESILIENT SEATED BUTTERFLY VALVES

GRW/GRL

MATERIAL SPECIFICATION - REINFORCED SEAT

Part name	Material	Material specification	Remark
DN 350 - 600 (NPS 14 - 24)			
Body	Ductile iron	ASTM A536 Gr 65-45-12	(Optional)
	Carbon steel	ASTM A395 Gr 60-40-18	
	316 stainless steel	ASTM A216 WCB	
	Duplex	ASTM A351 Gr CF8M	
	Super Duplex	ASTM A890 Gr 4A	
Disc	316 Stainless steel	ASTM A890 Gr 5A	CTD = Epoxy coated, max. temp. 120°C (250°F)
	Nickel aluminium bronze	ASTM A351 Gr CF8M	
	Ductile iron ctd	ASTM B148 UNS C95800	
Shaft	431 Stainless steel	ASTM A536 Gr 65-45-12	
	Super duplex	ASTM A276 Gr 431 S43100	
Seat	EPDM E6	ASTM A276 UNS S32750	Metal reinforced EPDM, Food Grade
	NBR N8		Metal reinforced NBR, Food Grade
Disc screw	Duplex	ASTM A276 UNS S31803	
Disc screw o-ring	NBR		
Plug	Carbon steel		
Plug o-ring	NBR		
Plug circlip	Stainless steel		
Bushing	Polyester		
Shaft/body o-ring	NBR		
Bearing	PTFE/steel		
Shaft/body circlip	Stainless steel		

NOTES

Valves with super duplex disc will have super duplex disc screw. All other discs will have a duplex disc screw.

KEYSTONE SERIES GR RESILIENT SEATED BUTTERFLY VALVES

GRW/GRL - METRIC DATA

SERIES GRW (WAFER)
DN 50-300

DN 350-900

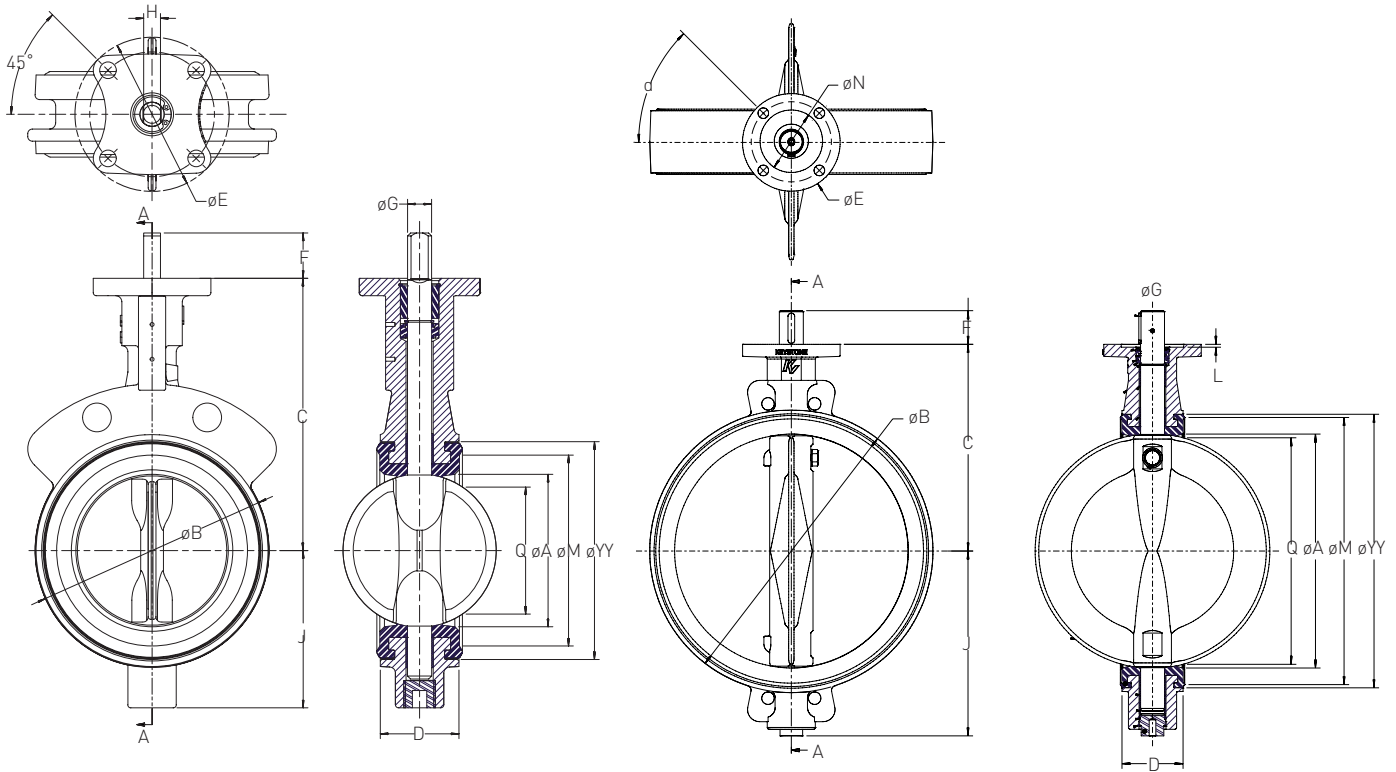

VALVE DIMENSIONS (mm)

Size (DN)													Shaft			Top plate drilling			Adapt. code ⁽⁴⁾	Weight ⁽³⁾ (kg)	
	A	B	C	D	E	F	J	L	M	N	Q ⁽¹⁾	YY	G	H ⁽²⁾	Key	Bolt circle	No. holes	a			Hole dia.
50	50	91	135	43	100	30	60	-	66	-	28	80	15.88	11.11	-	82.5	4	45°	11.0	BAC	2.0
65	62	105	150	46	100	30	76	-	78	-	43	93	14.29	9.53	-	82.5	4	45°	11.0	BAB	2.7
80	77	123	160	46	100	30	82	-	97	-	65	112	14.29	9.53	-	82.5	4	45°	11.0	BAC	3.2
100	99	154	180	52	100	30	104	-	129	-	87	144	15.88	11.11	-	82.5	4	45°	11.0	BAC	4.3
125	124	187	195	56	100	30	120	-	160	-	113	175	19.05	12.70	-	82.5	4	45°	11.0	BAD	5.9
150	150	208	210	56	100	30	131	-	181	-	142	196	19.05	12.70	-	82.5	4	45°	11.0	BAD	6.8
200	195	265	240	60	150	32	162	-	233	-	188	248	22.23	15.88	-	127.0	4	45°	13.5	CAE	11.8
250	245	320	275	68	150	50	198	-	290	-	237	305	28.58	-	6.4 x 6.4	127.0	4	45°	13.5	CAF	19.1
300	291	372	310	78	150	50	230	-	340	-	283	355	28.58	-	6.4 x 6.4	127.0	4	45°	13.5	CAF	26.8
350	325	416	325	78	150	76	260	-	378	-	318	398	35.00	-	8 x 8	127.0	4	45°	13.5	CAG	40.0
400	380	474	360	102	150	76	298	-	435	-	368	455	35.00	-	8 x 8	127.0	4	45°	13.5	CAG	61.0
450	434	534	395	114	200	76	334	6	495	130	421	515	41.35	-	9.5 x 9.5	165.0	4	45°	22.0	DAH	86.0
500	486	589	430	127	200	108	385	6	549	130	471	569	47.60	-	12.7 x 9.5	165.0	4	45°	22.0	DAJ	106.0
600	585	691	500	154	200	108	456	6	650	130	568	670	47.60	-	12.7 x 9.5	165.0	4	45°	22.0	DAJ	158.0
700	685	800	570	165	200	108	518	6	755	130	668	775	57.20	-	12.7 x 9.5	165.0	4	45°	22.0	DAK	231.0
750	735	862	605	165	200	108	551	6	816	130	719	835	57.20	-	12.7 x 9.5	165.0	4	45°	22.0	DAK	271.0
800	785	907	640	190	300	90	583	6	860	200	765	880	73.00	-	19 x 12.7	254.0	8	22.5°	17.5	KAV	326.0
900	885	1007	715	203	300	140	659	6	960	200	864	980	73.00	-	19 x 12.7	254.0	8	22.5°	17.5	KAV	419.0

NOTES

- 'Q' dimension is the minimum allowable pipe or flange inside diameter at the centered body face to protect the disc sealing edge against damage when opening the valve.
- 'H' dimension refers to flat on shaft.
- Weight may vary depending on trim materials used.
- DN 50 - actual shaft dimension is 12 mm x 8 mm A/F and is fitted with an adaptor to produce a BAC connection. Actual "F" dimension without adaptor is 25.
- øYY dimension is to the outside of the seat.
- øM dimension is to the O-ring seal.

KEYSTONE SERIES GR RESILIENT SEATED BUTTERFLY VALVES

GRW/GRL - METRIC DATA

SERIES GRL (LUG)
DN 50-300

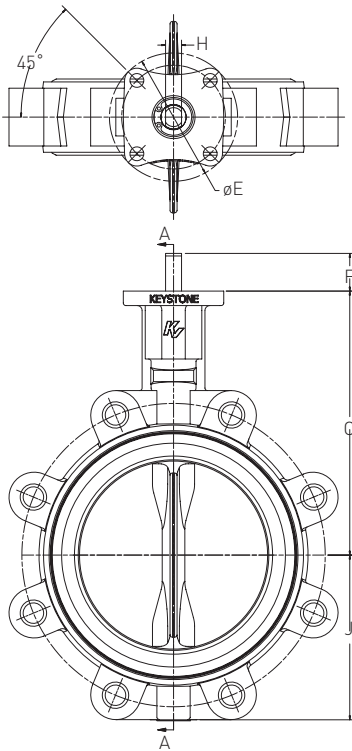

DN 350-900

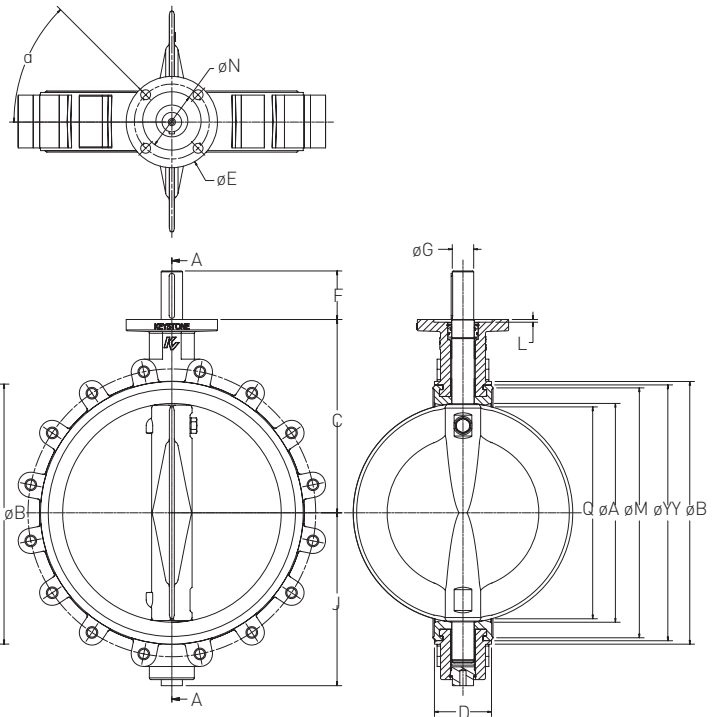

VALVE DIMENSIONS (mm)

Size (DN)													Shaft			Top plate drilling				Adapt. code ⁽⁴⁾	Weight ⁽³⁾ (kg)
	A	B	C	D	E	F	J	L	M	N	Q ⁽¹⁾	YY	G	H ⁽²⁾	Key	Bolt circle	No. holes	a	Hole dia.		
50	50	92	135	43	100	30	60	-	66	-	28	80	15.88	11.11	-	82.5	4	45°	11.0	BAC	3.0
65	62	105	150	46	100	30	76	-	78	-	43	93	14.29	9.53	-	82.5	4	45°	11.0	BAB	4.0
80	77	126	160	46	100	30	82	-	97	-	65	112	14.29	9.53	-	82.5	4	45°	11.0	BAB	4.5
100	99	156	180	52	100	30	104	-	129	-	87	144	15.88	11.11	-	82.5	4	45°	11.0	BAC	7.0
125	124	190	195	56	100	30	120	-	160	-	113	175	19.05	12.70	-	82.5	4	45°	11.0	BAD	10.0
150	150	214	210	56	100	30	131	-	181	-	142	196	19.05	12.70	-	82.5	4	45°	11.0	BAD	11.0
200	195	268	240	60	150	32	162	-	233	-	188	248	22.23	15.88	-	127.0	4	45°	13.5	CAE	17.0
250	245	321	275	68	150	50	198	-	290	-	237	305	28.58	-	6.4 x 6.4	127.0	4	45°	13.5	CAF	29.5
300	291	375	310	78	150	50	230	-	340	-	283	355	28.58	-	6.4 x 6.4	127.0	4	45°	13.5	CAF	41.0
350	325	416	325	78	150	76	260	-	378	-	318	398	35.00	-	8 x 8	127.0	4	45°	13.5	CAG	52.0
400	380	474	360	102	150	76	298	-	435	-	368	455	35.00	-	8 x 8	127.0	4	45°	13.5	CAG	88.0
450	434	534	395	114	200	76	334	6	495	130	421	515	41.35	-	9.5 x 9.5	165.0	4	45°	22.0	DAH	107.0
500	486	589	430	127	200	108	385	6	549	130	471	569	47.60	-	12.7 x 9.5	165.0	4	45°	22.0	DAJ	161.0
600	585	691	500	154	200	108	456	6	650	130	568	670	47.60	-	12.7 x 9.5	165.0	4	45°	22.0	DAJ	235.0
700	685	800	570	165	200	108	518	6	755	130	668	775	57.20	-	12.7 x 9.5	165.0	4	45°	22.0	DAK	315.0
750	735	862	605	165	200	108	551	6	816	130	719	835	57.20	-	12.7 x 9.5	165.0	4	45°	22.0	DAK	378.0
800	785	907	640	190	300	90	583	6	860	200	765	880	73.00	-	19 x 12.7	254.0	8	22.5°	17.5	KAV	438.0
900 ⁽⁵⁾	885	1007	715	203	300	140	659	6	960	200	864	980	73.00	-	19 x 12.7	254.0	8	22.5°	17.5	KAV	559.0

NOTES

- 'Q' dimension is the minimum allowable pipe or flange inside diameter at the centered body face to protect the disc sealing edge against damage when opening the valve.
- 'H' dimension refers to flat on shaft.
- Weight may vary depending on trim materials used.
- DN 50 - actual shaft dimension is 12 mm x 8 mm A/F and is fitted with an adaptor to produce a BAC connection. Actual "F" dimension without Adapter is 25.
- Valve size DN 900 is tapped flange design and has no separate lugs.
- ØYY dimension is to the outside of the seat.
- ØM dimension is to the O-ring seal.

KEYSTONE SERIES GR RESILIENT SEATED BUTTERFLY VALVES

GRW/GRL - IMPERIAL DATA

SERIES GRW (WAFER)

NPS 2-12

NPS 14-36

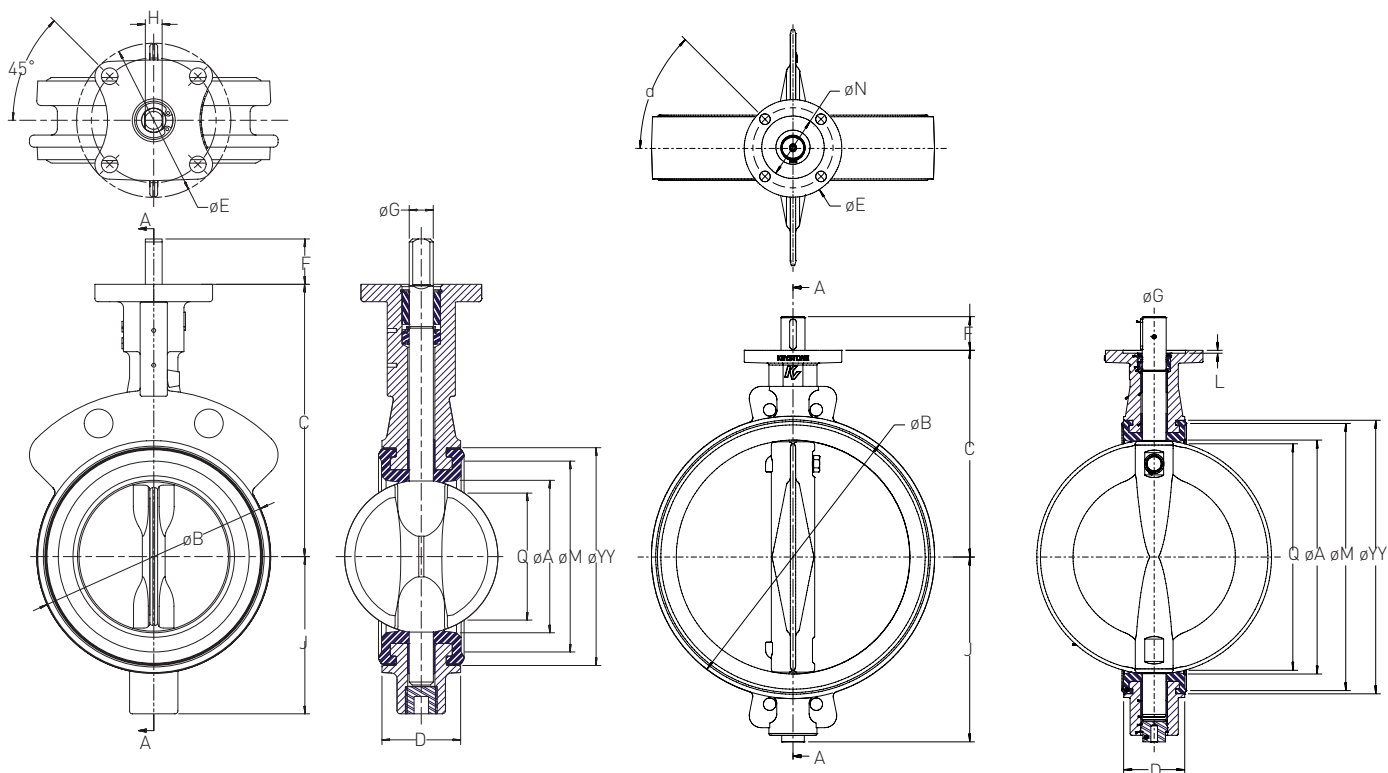

VALVE DIMENSIONS (in)

Size (NPS)	A	B	C	D	E	F	J	L	M	N	Q ⁽¹⁾	YY	Shaft			Top plate drilling			Adapt. code ⁽⁴⁾	Weight ⁽³⁾ (lbs)	
													G	H ⁽²⁾	Key	Bolt circle	No. holes	Hole dia.			
2	1.97	3.58	5.31	1.69	3.94	1.18	2.36	-	2.60	-	1.10	3.15	5/8	7/16	-	3 1/4	4	45°	0.43	BAC	4.5
2.5	2.44	4.13	5.91	1.81	3.94	1.18	2.99	-	3.07	-	1.70	3.66	5/16	3/8	-	3 1/4	4	45°	0.43	BAB	6
3	3.03	4.84	6.30	1.81	3.94	1.18	3.23	-	3.82	-	2.56	4.41	5/16	3/8	-	3 1/4	4	45°	0.43	BAB	7
4	3.90	6.06	7.09	2.05	3.94	1.18	4.09	-	5.08	-	3.43	5.67	5/8	7/16	-	3 1/4	4	45°	0.43	BAC	9.5
5	4.88	7.36	7.68	2.20	3.94	1.18	4.72	-	6.30	-	4.45	6.89	3/4	1/2	-	3 1/4	4	45°	0.43	BAD	13
6	5.91	8.19	8.27	2.20	3.94	1.18	5.16	-	7.13	-	5.59	7.72	3/4	1/2	-	3 1/4	4	45°	0.43	BAD	15
8	7.68	10.43	9.45	2.36	5.91	1.26	6.38	-	9.17	-	7.40	9.76	7/8	5/8	-	5	4	45°	0.53	CAE	26
10	9.65	12.6	10.83	2.68	5.91	1.97	7.80	-	11.42	-	9.33	12.01	1 1/8	-	1/4 x 1/4	5	4	45°	0.53	CAF	42
12	11.46	14.65	12.20	3.07	5.91	1.97	9.06	-	13.39	-	11.14	13.98	1 1/8	-	1/4 x 1/4	5	4	45°	0.53	CAF	59
14	12.80	16.38	12.80	3.07	5.90	2.99	10.24	-	14.88	-	12.50	15.67	1 3/8	-	5/16 x 5/16	5	4	45°	0.53	CAG	88
16	14.96	18.66	14.17	4.02	5.90	2.99	11.73	-	17.13	-	14.50	17.91	1 3/8	-	5/16 x 5/16	5	4	45°	0.53	CAG	134
18	17.09	21.02	15.55	4.49	8.00	2.99	13.15	0.24	19.49	5.12	16.60	20.28	1 3/8	-	3/8 x 3/8	6 1/2	4	45°	0.87	DAH	190
20	19.13	23.19	16.93	5.00	8.00	4.25	15.16	0.24	21.61	5.12	18.60	22.40	1 7/8	-	1/2 x 3/8	6 1/2	4	45°	0.87	DAJ	234
24	23.03	27.20	19.69	6.06	8.00	4.25	17.95	0.24	25.59	5.12	22.30	26.38	1 7/8	-	1/2 x 3/8	6 1/2	4	45°	0.87	DAJ	348
28	26.97	31.50	22.44	6.50	8.00	4.25	20.39	0.24	29.72	5.12	26.30	30.51	2 1/4	-	1/2 x 3/8	6 1/2	4	45°	0.87	DAK	509
30	28.94	33.94	23.82	6.50	8.00	4.25	21.69	0.24	32.13	5.12	28.30	32.87	2 1/4	-	1/2 x 3/8	6 1/2	4	45°	0.87	DAK	597
32	30.91	35.71	25.20	7.48	11.81	3.54	22.95	0.24	33.86	7.87	30.10	34.65	2 7/8	-	3/4 x 1/2	10	8	22.5°	0.69	KAV	719
36	34.84	39.65	28.15	7.99	11.81	5.51	25.94	0.24	37.80	7.87	34.00	38.58	2 7/8	-	3/4 x 1/2	10	8	22.5°	0.69	KAV	924

NOTES

1. 'Q' dimension is the minimum allowable pipe or flange inside diameter at the centered body face to protect the disc sealing edge against damage when opening the valve.
2. 'H' dimension refers to flat on shaft.
3. Weight may vary depending on trim materials used.
4. NPS 2 - actual shaft dimension is 1/2 in x 1/8 in A/F and is fitted with an adaptor to produce a BAC connection. Actual "F" dimension without Adapter is .98.
5. øYY dimension is to the outside of the seat.
6. øM dimension is to the O-ring seal.

KEYSTONE SERIES GR RESILIENT SEATED BUTTERFLY VALVES

GRW/GRL - IMPERIAL DATA

SERIES GRL (LUG)
NPS 2-12

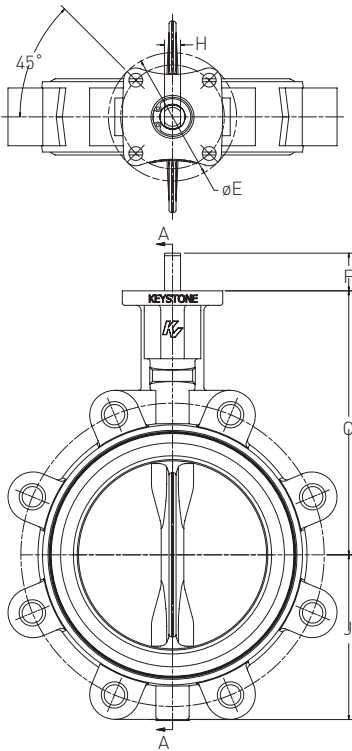

NPS 14-36

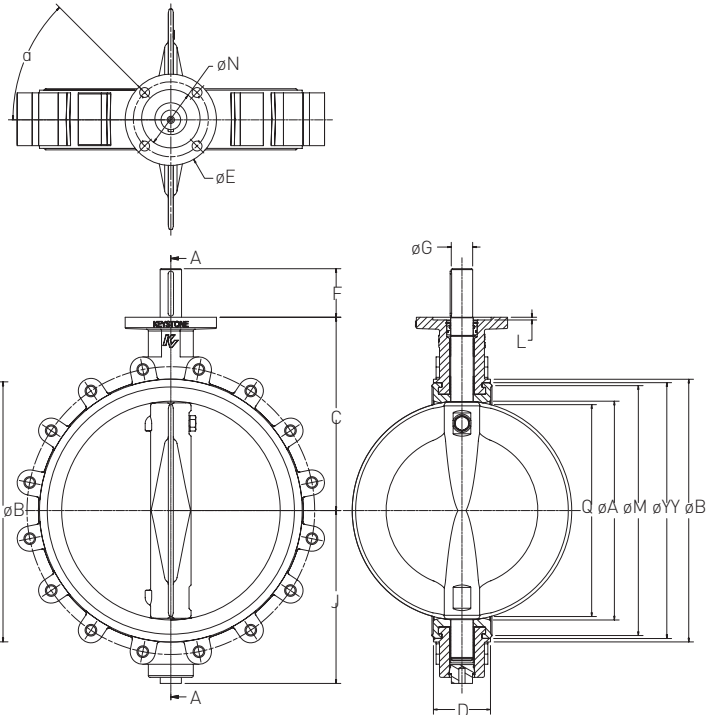

VALVE DIMENSIONS (in)

Size (NPS)	A	B	C	D	E	F	J	L	M	N	Q ⁽¹⁾	YY	Shaft			Top plate drilling			Adapt. code ⁽⁴⁾	Weight ⁽³⁾ (lbs)	
													G	H ⁽²⁾	Key	Bolt circle	No. holes	Hole dia.			
2	1.97	3.62	5.31	1.69	3.94	1.18	2.36	-	2.60	-	1.10	3.15	5/8	7/16	-	3 1/4	4	45°	0.43	BAC	7
2.5	2.44	4.13	5.91	1.81	3.94	1.18	2.99	-	3.07	-	1.70	3.66	7/16	3/8	-	3 1/4	4	45°	0.43	BAB	9
3	3.03	4.96	6.30	1.81	3.94	1.18	3.23	-	3.82	-	2.56	4.41	7/16	3/8	-	3 1/4	4	45°	0.43	BAB	10
4	3.90	6.14	7.09	2.05	3.94	1.18	4.09	-	5.08	-	3.43	5.67	5/8	7/16	-	3 1/4	4	45°	0.43	BAC	15
5	4.88	7.48	7.68	2.20	3.94	1.18	4.72	-	6.30	-	4.45	6.89	3/4	1/2	-	3 1/4	4	45°	0.43	BAD	21.5
6	5.91	8.43	8.27	2.20	3.94	1.18	5.16	-	7.13	-	5.59	7.72	3/4	1/2	-	3 1/4	4	45°	0.43	BAD	24
8	7.68	10.55	9.45	2.36	5.91	1.26	6.38	-	9.17	-	7.40	9.76	7/8	5/8	-	5	4	45°	0.53	CAE	38
10	9.65	12.60	10.83	2.68	5.91	1.97	7.80	-	11.42	-	9.33	12.01	1 1/8	-	1/4 x 1/4	5	4	45°	0.53	CAF	65
12	11.46	14.76	12.20	3.07	5.91	1.97	9.06	-	13.39	-	11.14	13.98	1 1/8	-	1/4 x 1/4	5	4	45°	0.53	CAF	90
14	12.80	16.38	12.80	3.07	5.90	2.99	10.24	-	14.88	-	12.51	15.67	1 3/8	-	5/16 x 5/16	5	4	45°	0.53	CAG	115
16	14.96	18.66	14.17	4.02	5.90	2.99	11.73	-	17.13	-	14.50	17.91	1 3/8	-	5/16 x 5/16	5	4	45°	0.53	CAG	194
18	17.09	21.02	15.55	4.49	8.00	2.99	13.15	0.24	19.49	5.12	16.58	20.28	1 5/8	-	3/8 x 3/8	6 1/2	4	45°	0.87	DAH	236
20	19.13	23.19	16.93	5.00	8.00	4.25	15.16	0.24	21.61	5.12	18.56	22.40	1 7/8	-	1/2 x 3/8	6 1/2	4	45°	0.87	DAJ	355
24	23.03	27.20	19.69	6.06	8.00	4.25	17.95	0.24	25.59	5.12	22.35	26.38	1 7/8	-	1/2 x 3/8	6 1/2	4	45°	0.87	DAJ	518
28	26.97	31.50	22.44	6.50	8.00	4.25	20.39	0.24	29.72	5.12	26.30	30.51	2 1/4	-	1/2 x 3/8	6 1/2	4	45°	0.87	DAK	694
30	28.94	33.94	23.82	6.50	8.00	4.25	21.69	0.24	32.13	5.12	28.31	32.87	2 1/4	-	1/2 x 3/8	6 1/2	4	45°	0.87	DAK	833
32	30.91	35.71	25.20	7.48	11.81	3.54	22.95	0.24	33.86	7.87	30.12	34.65	2 7/8	-	3/4 x 1/2	10	8	22.5°	0.69	KAV	966
36 ⁽⁵⁾	34.84	39.65	28.15	7.99	11.81	5.51	25.94	0.24	37.80	7.87	34.03	38.58	2 7/8	-	3/4 x 1/2	10	8	22.5°	0.69	KAV	1232

For ASME 125/150 - flange bolt threads for NPS 2-16 are UNC
- flange bolt threads for NPS 18-36 are 8UN

NOTES

1. 'Q' dimension is the minimum allowable pipe or flange inside diameter at the centered body face to protect the disc sealing edge against damage when opening the valve.
2. 'H' dimension refers to flat on shaft.
3. Weight may vary depending on trim materials used.
4. NPS 2 - actual shaft dimension is 1/2 in x 1/3 in A/F and is fitted with an adaptor to produce a BAC connection. Actual "F" dimension without the Adapter is .98.
5. Valve size NPS 36 is tapped flange design and has no separate lugs.
6. ϕYY dimension is to the outside of the seat.
7. ϕM dimension is to the O-ring seal.

KEYSTONE SERIES GR RESILIENT SEATED BUTTERFLY VALVES

GRW/GRL - METRIC DATA

DIMENSIONS OF TAPPED FLANGE LOCATING HOLES (mm)

Size (DN)	Series GRW		Series GRL	
	U	V	U	V
700	45.5	5.5	45.5	5.5
750	52.5	12.5	45.5	5.5
800	60.0	20.0	45.5	5.5
900	54.5	6.5	54.5	6.5

Note: all holes in lugged version are through threaded, except the holes closest to top and bottom shaft.

SERIES GRW AND GRL

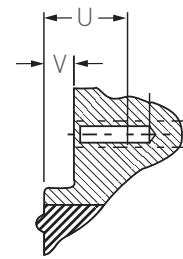

PRESSURE-TEMPERATURE DIAGRAM

Seat material*	Disc material**	Body material	Size range (DN)	Valve function Standard / End of Line	Temperature (°C)												
					-40	-28	-20	-15	0	50	100	120	130	150	160		
EPDM***	all	DI ASTM A536 CS ASTM A216 WCB	50-300	Std / EOL						16 bar / 10 bar							
EPDM	all	316 SS, Super Duplex, Duplex, DI ASTM A395	50-300	Std / EOL						16 bar / 10 bar							
NBR and white NBR	all	all	50-300	Std / EOL						16 bar / 10 bar							
HNBR	all	all	50-300	Std / EOL						16 bar / 10 bar							
FKM	all	all	50-300	Std / EOL						16 bar / 10 bar						10 bar / 6 bar	
EPDM***	all	DI ASTM A536 CS ASTM A216 WCB	350-900	Std / EOL						10 bar / 6 bar							
EPDM	all	316 SS, Super Duplex, Duplex, DI ASTM A395	350-600	Std / EOL						10 bar / 6 bar							
NBR	all	all	350-900	Std / EOL						10 bar / 6 bar							
HNBR	all	all	350-900	Std / EOL						10 bar / 6 bar							
FKM	all	all	350-900	Std / EOL						10 bar / 6 bar						6 bar / 4 bar	
EPDM E6	all	all	350-600	Std / EOL						16 bar / 10 bar							
NBR N8	all	all	350-600	Std / EOL						16 bar / 10 bar							

* All seat materials drop tight

** Per material listed in the material specification tables

For non-PED requirements with EPDM seats, valves can be rated to a minimum temperature of -40°C.

Maximum temperature for ductile iron disc/epoxy ctd. [DN 350-900] is 120°C.

Maximum temperature for ductile iron disc/nylon ctd. is 60°C.

FLOWRATE CO-EFFICIENTS - K_v VALUES

Valve size (DN)	Disc opening (degrees)									
	10°	20°	30°	40°	50°	60°	70°	80°	90°	
50	0	0.9	4.8	14	30	47	72	99	108	
65	0	2.4	11.0	27	50	78	123	172	217	
80	0	6.0	28.0	55	91	141	215	304	409	
100	0	14.0	57.0	109	177	265	407	600	807	
125	0	28.0	85.0	158	250	389	630	964	1251	
150	7	52.0	130.0	226	367	578	987	1551	1946	
200	22	115.0	231.0	405	646	1029	1773	2910	3516	
250	34	173.0	339.0	641	980	1546	2677	4449	5806	
300	49	253.0	495.0	935	1430	2255	3905	6710	8910	
350	119	304.0	637.0	1142	1936	3110	5010	8969	10407	
400	155	397.0	832.0	1492	2529	4062	6544	11714	13592	
450	196	503.0	1053.0	1888	3200	5141	8288	14826	17203	
500	242	621.0	1300.0	2331	3951	6347	10224	18303	21238	
600	349	894.0	1871.0	3357	5689	9140	14723	26357	30583	
700	475	1216.0	2547.0	4569	7744	12440	20040	35875	41626	
750	545	1396.0	2924.0	5245	8890	14281	23005	41183	47785	
800	620	1589.0	3327.0	5968	10114	16248	26174	46857	54369	
900	785	2011.0	4211.0	7553	12801	20564	33127	59303	68811	

Note: K_v = The volume of water in m³/hr that will pass through a valve with a pressure drop of 1 bar at 20°C.

MAXIMUM ALLOWABLE SHAFT TORQUES (Nm)

Shaft material	Valve size (DN)																	
	50	65	80	100	125	150	200	250	300	350	400	450	500	600	700	750	800	900
316SS	65	110	110	160	260	260	380	762	762									
431SS	90	155	155	230	365	365	650	1307	1307	1542	1824	2977	3219	5086	6312	7128	7088	14740
Duplex										1156	1368	2233	2414	3815	4734	5346	5316	11055
Super duplex	85	142	142	210	340	340	600	1200	1200	1413	1672	2729	2951	4366	5418	6118	6084	12652
Monel® K500	76	129	129	190	306	306	540	1080	1080	1284	1520	2481	2682	4239	5260	5907	5907	12283

KEYSTONE SERIES GR RESILIENT SEATED BUTTERFLY VALVES

GRW/GRL - IMPERIAL DATA

DIMENSIONS OF TAPPED FLANGE LOCATING HOLES (in)

Size (NPS)	Series GRW		Series GRL	
	U	V	U	V
28	1.8	0.22	1.8	0.22
30	2.1	0.49	1.8	0.22
32	2.4	0.79	1.8	0.22
36	2.1	0.26	2.1	0.26

Note: all holes in lugged version are through threaded, except the holes closest to top and bottom shaft.

SERIES GRW AND GRL

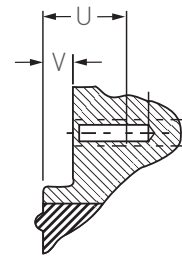

PRESSURE-TEMPERATURE DIAGRAM

Seat material*	Disc material**	Body material	Size range (NPS)	Valve function Standard / End of Line	Temperature (°F)								
					-40	-20	0	32	122	212	248	266	302
EPDM***	all	DI ASTM A536 CS ASTM A216 WCB	2-12	Std / EOL				230 psi / 150 psi					
EPDM	all	316 SS, Super Duplex, Duplex, DI ASTM A395	2-12	Std / EOL				230 psi / 150 psi					
NBR and white NBR	all	all	2-12	Std / EOL				230 psi / 150 psi					
HNBR	all	all	2-12	Std / EOL				230 psi / 150 psi					
FKM	all	all	2-12	Std / EOL				230 psi / 150 psi				150 psi / 90 psi	
EPDM***	all	DI ASTM A536 CS ASTM A216 WCB	14-36	Std / EOL				150 psi / 90 psi					
EPDM	all	316 SS, Super Duplex, Duplex, DI ASTM A395	14-24	Std / EOL				150 psi / 90 psi					
NBR	all	all	14-36	Std / EOL				150 psi / 90 psi					
HNBR	all	all	14-36	Std / EOL				150 psi / 90 psi					
FKM	all	all	14-36	Std / EOL				150 psi / 90 psi				90 psi / 60 psi	
EPDM E6	all	all	14-24	Std / EOL				230 psi / 150 psi					
NBR N8	all	all	14-24	Std / EOL				230 psi / 150 psi					

* All seat materials drop tight

** Per material listed in the material specification tables

For non-PED requirements with EPDM seats, valves can be rated to a minimum temperature of -40°F.

Maximum temperature for ductile iron disc/epoxy ctd. (NPS 14-36) is 248°F. Maximum temperature for ductile iron disc/nylon ctd is 140°F.

FLOWRATE CO-EFFICIENTS - C_v VALUES

Valve size (NPS)	Disc opening (degrees)									
	10°	20°	30°	40°	50°	60°	70°	80°	90°	
2	0	1.0	6	16	35	54	83	114	125	
2.5	0	2.8	13	31	58	90	142	199	251	
3	0	7	32	64	105	163	249	351	473	
4	0	16	66	126	205	306	471	694	933	
5	0	32	98	183	289	450	728	1114	1446	
6	8	60	150	261	424	668	1141	1793	2250	
8	25	133	267	468	747	1190	2050	3364	4065	
10	39	200	392	741	1133	1787	3095	5143	6712	
12	57	292	572	1081	1653	2607	4514	7757	10301	
14	138	351	736	1320	2238	3595	5792	10369	12031	
16	179	459	962	1725	2924	4696	7565	13542	15713	
18	227	582	1217	2183	3699	5943	9582	17140	19888	
20	280	718	1503	2695	4568	7338	11820	21160	24553	
24	403	1034	2163	3881	6577	10566	17021	30471	35356	
28	549	1406	2945	5282	8953	14382	23168	41474	48123	
30	630	1614	3380	6064	10277	16510	26595	47610	55243	
32	717	1837	3846	6899	11692	18784	30259	54170	62854	
36	908	2325	4868	8732	14799	23773	38297	68558	79550	

Note: C_v = The volume of water in U.S.gpm that will pass through a valve with a pressure drop of 1 psi at 70°F.

MAXIMUM ALLOWABLE SHAFT TORQUES (in lbs)

Shaft material	Valve size (NPS)																	
	2	2.5	3	4	5	6	8	10	12	14	16	18	20	24	28	30	32	36
316SS	575	975	975	1415	2300	2300	3360	6740	6740									
431SS	800	1370	1370	2035	3230	3230	5750	11570	11570	13650	16140	26350	29490	45010	55860	63100	62750	130500
Duplex										10230	12110	19760	21370	33770	41900	47300	47050	97900
Super duplex	750	1260	1260	1860	3010	3010	5310	10620	10620	12510	14800	24150	26115	38640	47950	54150	53850	112000
Monel® K500	670	1140	1140	1680	2710	2710	4780	9560	9560	11360	13450	21960	23740	37520	46550	52570	52280	108700

KEYSTONE SERIES GR RESILIENT SEATED BUTTERFLY VALVES

GRW/GRL - METRIC DATA

VALVE SEATING AND UNSEATING TORQUES (Nm)

Application ΔP (bar)	Valve size (DN)																	
	50	65	80	100	125	150	200	250	300	350	400	450	500	600	700	750	800	900
I																		
3.5	13	19	26	37	58	81	148	241	345	467	639	845	1089	1700	2494	2967	3495	4422
7	13	20	27	40	63	88	164	271	387	520	719	960	1248	1979	2943	3521	4169	5275
10	14	21	30	44	70	99	188	315	451	595	832	1123	1473	2373	3575	4302	5120	6479
14	15	23	33	49	80	113	219	374	536	-	-	-	-	-	-	-	-	-
16	15	25	36	51	85	120	235	403	578	-	-	-	-	-	-	-	-	-
3.5 (U/C)	8	11	16	22	35	49	89	145	207	280	383	507	653	1020	1497	1780	2097	2653
II																		
3.5	14	21	29	42	66	93	169	274	392	528	718	945	1212	1877	2736	3245	3811	4822
7	14	22	31	45	71	100	185	303	434	580	796	1058	1369	2153	3180	3793	4479	5667
10	15	23	33	49	78	111	208	347	498	652	906	1217	1590	2542	3804	4565	5419 ⁽¹⁾	6858
14	16	26	36	54	88	125	240	406	583	-	-	-	-	-	-	-	-	-
16	17	27	38	56	93	132	255	436	626	-	-	-	-	-	-	-	-	-
3.5 (U/C)	8	13	17	25	40	56	101	164	235	317	431	567	727	1126	1642	1947	2287	2893
III																		
3.5	15	23	32	48	74	105	190	306	439	588	797	1045	1336	2055	2978	3523	4127	5222
7	16	24	34	50	79	112	206	336	481	639	874	1156	1490	2328	3417	4065	4788	6059
10	16	26	36	54	86	122	229	380	545	709	981	1312	1707	2710	4034	4828	5719 ⁽¹⁾	7237
14	17	28	40	59	96	136	261	439	629	-	-	-	-	-	-	-	-	-
16	18	29	41	61	101	143	276	468	672	-	-	-	-	-	-	-	-	-
3.5 (U/C)	9	14	19	29	44	63	114	184	263	353	478	627	801	1233	1787	2114	2476	3133
IV																		
3.5	17	26	37	55	86	122	221	355	509	679	915	1195	1521	2322	3341	3940	4601	5822
7	18	27	39	58	91	129	237	384	551	728	990	1303	1671	2589	3772	4473	5252	6646
10	18	29	41	62	99	140	260	428	615	795	1094	1454	1883	2963	4378	5223	6168 ⁽¹⁾	7805
14	19	31	45	67	108	154	292	487	700	-	-	-	-	-	-	-	-	-
16	20	32	46	69	113	161	307	517	742	-	-	-	-	-	-	-	-	-
3.5 (U/C)	10	16	22	33	52	73	133	213	305	408	549	717	913	1393	2005	2364	2761	3493

NOTES

3.5 U/C refers to reduced diameter disc option.

1. Duplex shaft not suitable for these conditions, use only 431 stainless steel or super duplex.

TORQUE APPLICATION FACTOR CATEGORIES

Application I

Clean liquid lubricating media (water, clean oils, lube oil, mineral oil, etc.); and with no deposit or chemical attack, valve operated at least once a week. Temperature range from 0°C to maximum temperature rating of the elastomer seat.

Application II

Other liquid media and lubricating gases (aqueous liquids, such as food and beverage, water, etc.); and with minor deposit or chemical attack, valve operated at least once a month.

Temperature range from 0°C to maximum temperature rating of the elastomer seat.

Application III

- Dry non-abrasive media or gases (non-abrasive powders and dry gas); or
- Fluids with moderate deposit or chemical attack; or
- Valves operated less than once a month.

Temperature range from 0°C to maximum temperature rating of the elastomer seat.

Application IV

- Dry abrasive media and degreasing applications (sand, cement, silicone free, oxygen cleaned); or
- Liquids with severe deposit; or
- Valves not frequently operated (once a year).

All above with temperature range from -10°C to maximum temperature rating of the elastomer seat.

NOTES

1. For applications with temperatures above or below the guidelines above, please consult factory.

2. For dry service valves it is suggested to use U/C discs (reduced diameter) when service conditions are less than 3.5 bar.

KEYSTONE SERIES GR RESILIENT SEATED BUTTERFLY VALVES

GRW/GRL - IMPERIAL DATA

VALVE SEATING AND UNSEATING TORQUES (in lbs)

Application ΔP (psi)	Valve size (NPS)																	
	2	2.5	3	4	5	6	8	10	12	14	16	18	20	24	28	30	32	36
I																		
50	115	168	230	327	513	717	1310	2133	3054	4137	5654	7479	9635	15043	22076	26264	30933	39137
100	115	177	239	354	558	779	1452	2399	3425	4605	6363	8500	11048	17518	26045	31164	36899	46688
150	124	186	266	389	620	876	1664	2788	3992	5262	7360	9936	13038	21007	31641	38076	45315	57340
200	133	204	292	434	708	1000	1938	3310	4744	-	-	-	-	-	-	-	-	-
230	133	221	319	451	752	1062	2080	3567	5116	-	-	-	-	-	-	-	-	-
50 (U/C)	69	101	138	196	308	430	786	1280	1832	2482	3393	4487	5781	9026	13246	15758	18560	23482
II																		
50	124	186	257	372	584	823	1496	2425	3469	4673	6354	8364	10728	16617	24218	28723	33731	42679
100	124	195	274	398	628	885	1637	2682	3841	5129	7048	9366	12118	19059	28142	33572	39638	50155
150	133	204	292	434	690	982	1841	3071	4408	5770	8023	10775	14074	22498	33670	40404	47966 ⁽¹⁾	60695
200	142	230	319	478	779	1106	2124	3593	5160	-	-	-	-	-	-	-	-	-
230	150	239	336	496	823	1168	2257	3859	5541	-	-	-	-	-	-	-	-	-
50 (U/C)	74	112	154	223	350	494	897	1455	2082	2804	3812	5018	6437	9970	14531	17234	20239	25607
III																		
50	133	204	283	425	655	929	1682	2708	3885	5208	7053	9249	11821	18191	26361	31183	36529	46220
100	142	212	301	443	699	991	1823	2974	4257	5654	7733	10233	13188	20600	30239	35979	42378	53622
150	142	230	319	478	761	1080	2027	3363	4824	6277	8685	11614	15109	23989	35700	42734	50617 ⁽¹⁾	64050
200	150	248	354	522	850	1204	2310	3885	5567	-	-	-	-	-	-	-	-	-
230	159	257	363	540	894	1266	2443	4142	5948	-	-	-	-	-	-	-	-	-
50 (U/C)	80	122	170	255	393	558	1009	1625	2331	3125	4232	5550	7093	10915	15817	18710	21918	27732
IV																		
50	152	233	330	491	764	1081	1956	3141	4503	6012	8103	10577	13461	20552	29575	34872	40727	51533
100	157	242	344	513	807	1143	2095	3401	4878	6440	8760	11533	14794	22912	33385	39591	46487	58823
150	163	257	366	547	873	1237	2304	3792	5441	7038	9680	12872	16663	26226	38744	46229	54593 ⁽¹⁾	69083
200	171	275	394	591	959	1362	2582	4313	6191	-	-	-	-	-	-	-	-	-
230	175	285	408	613	1003	1425	2721	4574	6567	-	-	-	-	-	-	-	-	-
50 (U/C)	91	140	198	295	458	648	1174	1884	2702	3607	4862	6346	8076	12331	17745	20923	24436	30920

NOTES

50 U/C refers to reduced diameter disc option.

1. Duplex shaft not suitable for these conditions, use only 431 stainless steel or super duplex.

TORQUE APPLICATION FACTOR CATEGORIES

Application I

Clean liquid lubricating media (water, clean oils, lube oil, mineral oil, etc.); and with no deposit or chemical attack, valve operated at least once a week. Temperature range from 32°F to maximum temperature rating of the elastomer seat.

Application II

Other liquid media and lubricating gases (aqueous liquids, such as food and beverage, water, etc.); and with minor deposit or chemical attack, valve operated at least once a month.

Temperature range from 32°F to maximum temperature rating of the elastomer seat.

Application III

- Dry non-abrasive media or gases (non-abrasive powders and dry gas); or
- Fluids with moderate deposit or chemical attack; or
- Valves operated less than once a month.

Temperature range from 32°F to maximum temperature rating of the elastomer seat.

Application IV

- Dry abrasive media and degreasing applications (sand, cement, silicone free, oxygen cleaned); or
- Liquids with severe deposit; or
- Valves not frequently operated (once a year).

All above with temperature range from 15°F to maximum temperature rating of the elastomer seat.

NOTES

1. For applications with temperatures above or below the guidelines above, please consult factory.

2. For dry service valves it is suggested to use U/C discs (reduced diameter) when service conditions are less than 50 psi.

KEYSTONE SERIES GR RESILIENT SEATED BUTTERFLY VALVES

GRW/GRL - METRIC DATA

VALVE SEATING AND UNSEATING TORQUES (Nm) - REINFORCED SEAT

Differential pressure (bar)	Valve size (DN)				
	350	400	450	500	600
I*					
10	851	1173	1563	2026	3198
14	986	1374	1849	2419	3876
16	1053	1474	1992	2615	4216
II*					
10	947	1298	1721	2221	3879
14	1081	1499	2007	2614	4157
16	1149	1599	2150	2810	4496
III*					
10	1297	1755	2300	2936	4509
14	1432	1956	2586	3329	5187
16	1499	2057	2729	3525	5526

NOTES

As the reinforced seat is intended for high pressure applications the base torque commences at 1000 kPa/10 bar.

Reinforced seats are suitable for:

- Severe vacuum application (use 10 bar torque values).
- High line velocities up to 12 m/s for liquids.
- Pressure testing during erection and commissioning.

TORQUE APPLICATION FACTOR CATEGORIES

Application I

Clean liquid lubricating media (water, clean oils, lube oil, mineral oil, etc.);
and with no deposit or chemical attack, valve operated at least once a week.

Temperature range from 0°C to maximum temperature rating of the elastomer seat.

Application II

Other liquid media and lubricating gases (aqueous liquids, such as food and beverage, water, etc.);
and with minor deposit or chemical attack, valve operated at least once a month.

Temperature range from 0°C to maximum temperature rating of the elastomer seat.

Application III

- a. Dry non-abrasive media or gases (non-abrasive powders and dry gas); or
- b. Fluids with moderate deposit or chemical attack; or
- c. Valves operated less than once a month.

Temperature range from 0°C to maximum temperature rating of the elastomer seat.

NOTES

1. For applications with temperatures above or below the guidelines above, please consult factory.

KEYSTONE SERIES GR RESILIENT SEATED BUTTERFLY VALVES

GRW/GRL - IMPERIAL DATA

VALVE SEATING AND UNSEATING TORQUES (in lbs) - REINFORCED SEAT

Differential pressure (psi)	Valve size (NPS)				
	14	16	18	20	24
I*					
150	7532	10382	13834	17932	28305
200	8727	12161	16365	21410	34306
230	9320	13046	17631	23145	37315
II*					
150	8382	11488	15232	19658	34332
200	9568	13267	17763	23136	36793
230	10170	14152	19029	24871	39793
III*					
150	11479	15533	20357	25986	39908
200	12673	17310	22886	29461	45904
230	13266	18204	24151	31196	48905

NOTES

As the reinforced seat is intended for high pressure applications the base torque commences at 150 psi.

Reinforced seats are suitable for:

- Severe vacuum application (use 150 psi torque values).
- High line velocities up to 34.9 f/s for liquids.
- Pressure testing during erection and commissioning.

TORQUE APPLICATION FACTOR CATEGORIES

Application I

Clean liquid lubricating media (water, clean oils, lube oil, mineral oil, etc.); and with no deposit or chemical attack, valve operated at least once a week. Temperature range from 32°F to maximum temperature rating of the elastomer seat.

Application II

Other liquid media and lubricating gases (aqueous liquids, such as food and beverage, water, etc.); and with minor deposit or chemical attack, valve operated at least once a month. Temperature range from 32°F to maximum temperature rating of the elastomer seat.

Application III

- a. Dry non-abrasive media or gases (non-abrasive powders and dry gas); or
 - b. Fluids with moderate deposit or chemical attack; or
 - c. Valves operated less than once a month.
- Temperature range from 32°F to maximum temperature rating of the elastomer seat.

NOTES

1. For applications with temperatures above or below the guidelines above, please consult factory.

KEYSTONE SERIES GR RESILIENT SEATED BUTTERFLY VALVES

GRW/GRL

SELECTION GUIDE

Example:	GRL	0100	- D0	A1	S2	E0	A1	K	- 00	000	00
Series											
GR											
Body style											
GRL	Lug										
GRW	Wafer										
Size											
0050	DN 50/NPS 2	0200	DN 200/NPS 8	0500	DN 500/NPS 20						
0065	DN 65/NPS 2½	0250	DN 250/NPS 10	0600	DN 600/NPS 24						
0080	DN 80/NPS 3	0300	DN 300/NPS 12	0700	DN 700/NPS 28						
0100	DN 100/NPS 4	0350	DN 350/NPS 14	0750	DN 750/NPS 30						
0125	DN 125/NPS 5	0400	DN 400/NPS 16	0800	DN 800/NPS 32						
0150	DN 150/NPS 6	0450	DN 450/NPS 18	0900	DN 900/NPS 36						
Body											
D0	Ductile iron A536	C0	Carbon steel A216	U0	Duplex						
D2	Ductile iron A395	S0	Stainless steel A351	V0	Super Duplex						
Disc											
D0	Ductile iron - ENP (DN 50-300, NPS 2-12)			S1	304 stainless steel						
D1	Ductile iron - epoxy (DN 350-900, NPS 14-36)			A1	Aluminum bronze						
D2	Ductile iron - nylon ctd			N0	Nickel aluminum bronze						
D3	Ductile iron - FBE ⁽³⁾ ctd			U0	Duplex						
S0	316 stainless steel			V0	Super duplex ⁽²⁾						
Shaft											
S0	316 stainless steel ⁽¹⁾			U0	Duplex						
S2	431 stainless steel			V0	Super duplex						
				M1	Monel® K500						
Seat											
E0	EPDM FG (NSF ANSI/61 and ACS)			N8	NBR reinforced (DN 350-600, NPS 14-24)						
E6	EPDM reinforced (DN 350-600, NPS 14-24)			N9	White NBR						
H1	HNBR			F1	FKM						
N0	NBR FG										
Flange drilling											
Single drilled lug and wafer						Multi-drilled wafer					
A1	ASME 125/150		P1	ISO 7005 PN 6		M3	ASME 150, AS 2129E				
AD	AS 4087 PN 16/AS2129 Table D*		P2	ISO 7005 PN 10		M6	ASME 150, AS 2129E, AS 4087 PN 16				
AE	AS2129 table E		P3	ISO 7005 PN 16							
J1	JIS B2210 - 10K		PA	PN 6/10/16							
J5	JIS B2210 - 5K		PB	PN 10/16							
Actuator mounting											
K	Keystone mount										
Actuation											
00	None			G1	Gear - blue						
H1	10 pos handle - blue			G5	Chainwheel - blue						
Special											
000	None			C22	NSF/ANSI std 61						
P04	Reduced disc for 50 dpi			009	Silicone free						
Coating											
00	Standard			03	C5M blue ctd body						
02	C3 blue ctd body										

NOTES

- The standard shaft material is 431 stainless steel. 316 SS is only available as an option on DN 50-300 (NPS 2-12).
 - All disc screws will be of duplex except for super duplex disc which will have a super duplex disc screw.
 - FBE = Fusion bond epoxy
 - Carbon Steel and 316 Stainless Steel body material options are available up to and including DN 600 / NPS 24. Other options are available on request. Please consult your local sales representative.
- Monel® is a registered trademark of the Special Metals Corporation.

Neither Emerson, Emerson Automation Solutions, nor any of their affiliated entities assumes responsibility for the selection, use or maintenance of any product. Responsibility for proper selection, use, and maintenance of any product remains solely with the purchaser and end user.

Keystone is a mark owned by one of the companies in the Emerson Automation Solutions business unit of Emerson Electric Co. Emerson Automation Solutions, Emerson and the Emerson logo are trademarks and service marks of Emerson Electric Co. All other marks are the property of their respective owners.

The contents of this publication are presented for informational purposes only, and while every effort has been made to ensure their accuracy, they are not to be construed as warranties or guarantees, express or implied, regarding the products or services described herein or their use or applicability. All sales are governed by our terms and conditions, which are available upon request. We reserve the right to modify or improve the designs or specifications of such products at any time without notice.

Emerson.com/FinalControl