

84A-240 SERIES

CARBON STEEL 3-PIECE STANDARD PORT 1500 CWP SOCKET WELD BALL VALVE



STANDARD COMPLIANCE

- Valve Design: MSS SP-110, NACE MR0175 (2000) & MR0103 (2012)
- End Connections: Socket-weld per ASME B16.11

- Valve Marking: MSS SP-25
- Production Testing: MSS SP-110

FEATURES

- 3-piece construction with enclosed fasteners
- Standard port
- Stainless steel trim & hardware
- Swing-out center section
- Pressure balanced solid ball
- Compression controlled RPTFE gaskets

- Anti-blowout one piece bottom entry stem
- Two-position locking
- Adjustable multi-piece PTFE "V" style packing
- Fully machined ISO 5211 mounting
- Cast bosses on the center-section and end caps for bleed & drain ports
- Vacuum service to 29 in of Hg.
- 150 psig saturated steam

STANDARD MATERIAL LIST

	PART	MATERIAL
1	Body	ASTM A216-WCB
2	End Caps	ASTM A216-WCB
3	Ball	ASTM A276-316SS
4	Stem	ASTM A276-316SS
5	Seat	Multi-Seal
6	Packing	PTFE
7	Stem Bearing	PEEK/PTFE
8	Body Gasket	RPTFE
9	Body Bolts	18-8 Stainless Steel
10	Stop Bolts	18-8 Stainless Steel
11	Gland Bolts	18-8 Stainless Steel
12	Handle Nut/Screw	300 Series Stainless Steel
13	Packing Gland	ASTM A276-316SS
14	Gland Plate	300 Series Stainless Steel
15	Lever Handle	300 Series Stainless Steel
16	Lock Plate	300 Series Stainless Steel
17	Stops	300 Series Stainless Steel

OPTIONS AVAILABLE

(MORE INFORMATION IN SECTION J)

- Minimum quantities apply
- To specify an option, replace the "01" standard suffix with the suffix of the option.
- To specify multiple options, replace the "01" suffix with the desired suffixes in the numerical order shown below. NOTE: Not all suffixes can be combined together.

(SUFFIX)	OPTION	SIZES
-01	Standard Configuration	All
-04-	2.25" Stem Extension (Carbon Steel, Zinc Plated)	3/4" to 2-1/2"
-14-	Vented Ball	3/4" to 2-1/2"
-15-	Round Handle	3/4" to 2-1/2"
-49-	No Lubrication. Assembled Dry	3/4" to 2-1/2"
-60-	Static Grounding	3/4" to 2-1/2"
-62-	Center Section Only	3/4" to 2-1/2"
-67-	Cleaned for Industrial Gases	3/4" to 2-1/2"
-69-	Drilled & Tapped Purge & Drains	3/4" to 2-1/2"
-70-	4" Extended Bonnet	3/4" to 2-1/2"
-76-	Live Loaded (Lever Operated)	3/4" to 2-1/2"
-77-	Live Loaded (Actuated)	3/4" to 2-1/2"
-90-	Double Packed 4" Extended Bonnet	3/4" to 2-1/2"
-9P-	Double Packed 4" Extended Bonnet with Monitoring Port	3/4" to 2-1/2"
-KF-	PCTFE Stem Bearing	3/4" to 2-1/2"
-SR-	Spring Return Handle	3/4" to 1"

Pressure/Temperature Ratings - Page M-19, Graph No. 23

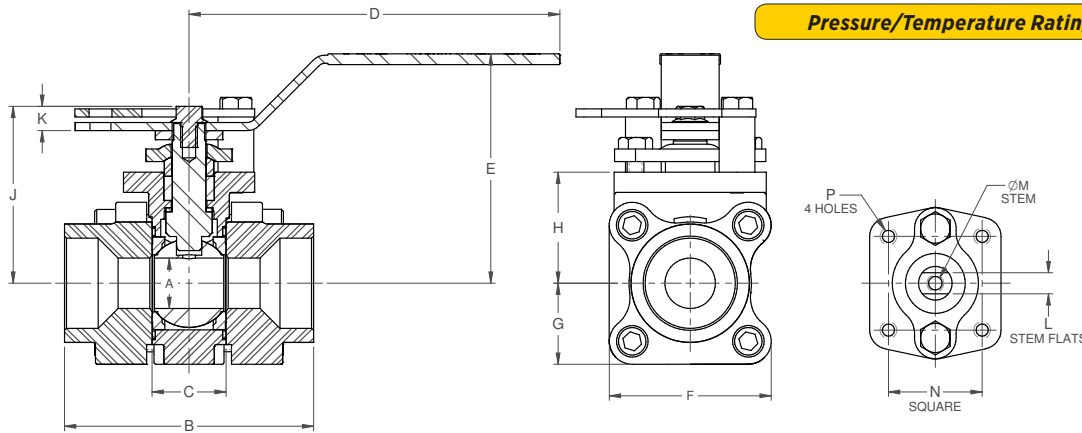

DIMENSIONS

PRODUCT NO.	SIZE	A	B	C	D	E	F	G	H	J	K	L	M	N	P	WT.
84A-244-01	3/4"	0.50	2.80	0.89	5.12	3.03	2.02	1.01	1.39	1.98	0.24	0.245	0.375	1.00	10-24	2.3
84A-245-01	1"	0.75	3.70	1.10	5.51	3.41	2.40	1.20	1.65	2.37	0.24	0.312	0.500	1.392	1/4-20	4.1
84A-247-01	1.5"	1.25	4.58	1.73	6.67	4.61	3.52	1.76	2.38	3.78	0.72	0.412	0.625	1.949	5/16-18	11.5
84A-248-01	2"	1.50	4.98	1.97	6.67	4.76	3.84	1.92	2.49	3.89	0.69	0.412	0.625	1.949	5/16-18	14.8
84A-249-01	2.5"	2.00	5.86	2.56	8.40	5.52	4.56	2.33	3.17	4.74	0.77	0.477	0.750	1.949	5/16-18	24.6