

76J-AR SERIES

DUPLEX STAINLESS STEEL STD. PORT BALL VALVE
W/ ACTUATOR READY ISO MOUNTING PAD



Female NPT Thread, 1/4"-1" 2000 CWP (psig), 1-1/4"-2" 1500 CWP (psig), 2-1/2"-3" 1000 CWP (psig). Cold Non-Shock.
250 psig Saturated Steam. (See referenced P/T chart)
Vacuum Service to 29 inches Hg.
MSS SP-110 Compliant.

FEATURES

- Multi-piece packing set
- ISO 5211 mounting pad
- Blowout-proof stem design

- Fire safe "by design" (requires -24 suffix)
- Adjustable packing gland
- Live loaded packing

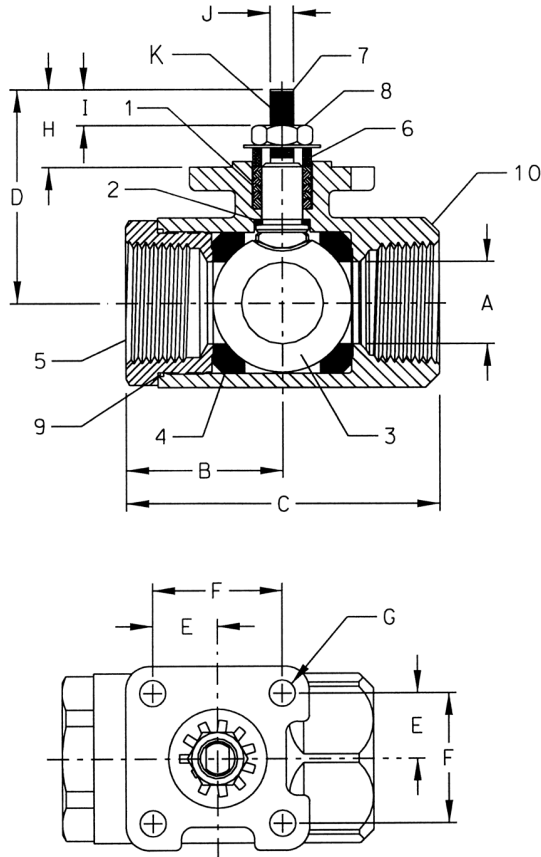

OPTIONS AVAILABLE

(MORE INFORMATION IN SECTION J)

- Minimum quantities apply
- To specify an option, replace the "01" standard suffix with the suffix of the option.
- To specify multiple options, replace the "01" suffix with the desired suffixes in the numerical order shown below. NOTE: Not all suffixes can be combined together.

(SUFFIX)	OPTION	SIZES
-01	Standard Configuration	All
-14-	Vented Ball	All
-24-	Graphite Packing (Fire Safe "By Design")	All
-27-	Latch Lock Handle	1/4" to 2"
-35-	PTFE Seats	All
-49-	No Lubrication. Assembled Dry.	All
-57-	Oxygen Cleaned	All

STANDARD MATERIAL LIST

	PART	MATERIAL
1	Stem packing	MPTFE
2	Stem bearing	PEEK/PTFE
3	Ball	ASTM A276/A479 Alloy 2205
4	Seat (2)	MPTFE
5	Retainer	ASTM A276/A479 Alloy 2205 (1/4" to 1") ASTM A995 4A (1-1/4" to 3")
6	Gland	ASTM A276-316
7	Stem	ASTM A276/A479 Alloy 2205
8	Jam nut	SS
9	Body seal	PTFE (1-1/4" to 3")
10	Body	ASTM A995 4A

Pressure/Temperature Ratings -
Page M-29, Graph No. 43 (1/4" to 1")
Page M-30, Graph No. 44 (1-1/4" to 2")
Page M-30, Graph No. 45 (2-1/2" to 3")

DIMENSIONS

PART NO.	SIZE	A	B	C	D	E	F	G	H	I	J (FLATS)	K (THRDS) UNF	WT.
76J-AR1-64	1/4"	0.37	1.02	2.04	1.40	0.59	1.17	0.28	0.61	0.25	.247/.249	3/8-24	0.52
76J-AR2-64	3/8"	0.37	1.02	2.04	1.40	0.59	1.17	0.28	0.61	0.25	.247/.249	3/8-24	0.48
76J-AR3-64	1/2"	0.50	1.12	2.23	1.54	0.59	1.17	0.28	0.61	0.22	.247/.249	3/8-24	0.58
76J-AR4-64	3/4"	0.68	1.47	2.96	2.16	0.70	1.39	0.28	0.84	0.33	.247/.249	3/8-24	1.26
76J-AR5-64	1"	0.87	1.66	3.34	2.28	0.70	1.39	0.28	0.84	0.32	.247/.249	3/8-24	1.62
76J-AR6-64	1-1/4"	1.00	2.00	4.00	2.98	0.98	1.95	0.34	1.21	0.43	.370/.372	5/8-18	3.22
76J-AR7-64	1-1/2"	1.25	2.18	4.34	3.16	0.98	1.95	0.34	1.16	0.38	.370/.372	5/8-18	4.06
76J-AR8-64	2"	1.50	2.75	5.43	3.37	0.98	1.95	0.34	1.16	0.47	.370/.372	5/8-18	6.18
76J-AR9-64	2-1/2"	2.00	3.12	6.25	3.85	0.98	1.95	0.34	1.16	0.41	.370/.372	5/8-18	12.96
76J-AR0-64	3"	2.50	3.37	6.75	4.18	0.98	1.95	0.34	1.16	0.55	.370/.372	5/8-18	17.06

FLOW DATA

FLOW DATA

The listed C_v "factors" are derived from actual flow testing, at Apollo's Pageland, South Carolina factory. These tests were completed using standard "off the shelf" valves with no special preparation and utilizing standard schedule 40 pipe. It should be understood that these factors are for the valve only and also include the connection configuration. The flow testing is done utilizing water as a fluid media and is a direct statement of the gallons of water flowed per minute with a 1 psig pressure differential across the valve/connection unit. Line pressure is not a factor. Because the C_v is a factor, the formula can be used to estimate flow of most media for valve sizing.

FLOW OF LIQUID

$$Q = C_v \sqrt{\frac{\Delta P}{SpGr}}$$

$$\text{or } \Delta P = \frac{(Q)^2 (SpGr)}{(C_v)^2}$$

WHERE:

- Q = Flow in US gpm
- ΔP = Pressure drop (psig)
- SpGr = Specific gravity at flowing temperature
- C_v = Valve constant

FLOW OF GAS

$$Q = 1360 C_v \sqrt{\frac{(\Delta P) (P_2)}{(SpGr) (T)}}$$

$$\text{or } \Delta P = \frac{5.4 \times 10^{-7} (SpGr) (T) (Q)^2}{(C_v)^2 (P_2)}$$

WHERE:

- Q = Flow in SCFH
- ΔP = Pressure drop (psig)
- SpGr = Specific gravity (based on air = 1.0)
- P_2 = Outlet pressure-psia (psig + 14.7)
- T = (temp. °F + 460)
- C_v = Valve constant

CAUTION: The gas equation shown, is valid at very low pressure drop ratios. The gas equation is NOT valid when the ratio of pressure drop (ΔP) to inlet pressure (P_1) exceeds 0.02.

NOTE: Only use the gas equation shown if $(P_1 - P_2)/P_1$ is less than 0.02.

CV FACTORS FOR APOLLO VALVES (CONTINUED ON M-4)

VALVE	SIZE (IN.)														
	1/4	3/8	1/2	3/4	1	1.25	1.5	2	2.5	3	4	6	8	10	12
70B-140 Series	8.4	7.2	15	30	43	48	84	108	190	370	670	--	--	--	--
70-100/200 Series	8.4	7.2	15	30	43	48	84	108	190	370	670	--	--	--	--
70-300/400 Series	--	--	15	30	43	48	84	108	--	--	--	--	--	--	--
70-600 Series	2.3	4.5	5.4	12	14	21	34	47	--	--	--	--	--	--	--
70-800 Series	8.4	7.2	15	30	43	48	84	--	--	--	--	--	--	--	--
71-AR Series	--	--	--	30	43	48	84	108	190	370	--	--	--	--	--
71-100/200 Series	--	--	--	30	43	48	84	108	190	370	--	--	--	--	--
72-100/900 Series	--	--	26	48	65	125	170	216	--	--	--	--	--	--	--
72-1xx-A/72-9xx-A Series	--	--	26	48	65	125	170	245	--	--	--	--	--	--	--
73A-100 Series	8.4	7.2	15	30	43	48	84	108	--	--	--	--	--	--	--
73-300/400 Series	--	--	26	48	65	125	170	216	--	--	--	--	--	--	--
74-100 Series	8.4	7.2	15	30	43	48	84	108	190	370	670	--	--	--	--
75-100 Series	8.4	7.2	15	30	43	48	84	108	190	370	670	--	--	--	--
76-AR Series	8.4	7.2	15	30	43	48	84	108	190	370	670	--	--	--	--
76F-100 Series	8.1	15	15	51	68	125	177	389	--	--	--	--	--	--	--
76FJ-100 Series	8.1	15	15	51	68	125	177	389	--	--	--	--	--	--	--
76FK-100 Series	8.1	15	15	51	68	125	177	389	--	--	--	--	--	--	--
76-100 Series	8.4	7.2	15	30	43	48	84	108	190	370	--	--	--	--	--
76-300/400 Series	--	--	26	48	65	125	170	216	--	--	--	--	--	--	--
76-600 Series	2.3	4.5	5.4	12	14	21	34	47	--	--	--	--	--	--	--
76J-100 Series	8.4	7.2	15	30	43	48	84	108	190	370	--	--	--	--	--
76J-AR Series	8.4	7.2	15	30	43	48	84	108	190	370	670	--	--	--	--
76K-100 Series	8.4	7.2	15	30	43	48	84	108	190	370	--	--	--	--	--
76K-AR Series	8.4	7.2	15	30	43	48	84	108	190	370	670	--	--	--	--
7K-100 Series	--	--	15	51	68	125	177	389	503	--	--	--	--	--	--
77-AR Series	8.1	15	15	51	68	--	177	389	--	--	--	--	--	--	--

REV. 21APR17

CV FACTORS FOR APOLLO VALVES (CONTINUED FROM M-3)

VALVE	SIZE (IN.)														
	1/4	3/8	1/2	3/4	1	1.25	1.5	2	2.5	3	4	6	8	10	12
77C-100/200 Series	4.5	7.2	16	36	68	125	177	389	503	--	--	--	--	--	--
77D-140 Series	4.5	7.2	16	36	68	125	177	389	--	--	--	--	--	--	--
77D-640 Series	--	--	--	11	24	35	--	--	--	--	--	--	--	--	--
77G-UL Series	4.5	7.2	16	36	68	125	177	389	503	--	--	--	--	--	--
77W Series	--	--	16	36	68	125	177	389	--	--	--	--	--	--	--
77-100/200 Series	8.1	15	15	51	68	125	177	389	503	--	--	--	--	--	--
79 Series	8.5	8.5	9.8	32	44	66	148	218	440	390	--	--	--	--	--
80 Series	8.4	7.2	15	30	43	48	84	108	190	370	--	--	--	--	--
82-100/200 Series	8.1	14	26	51	68	120	170	376	510	996	1893	--	--	--	--
83A/83B Series	8.1	14	26	51	68	120	170	376	--	--	--	--	--	--	--
83R-100/200 Series	--	--	--	--	--	--	170	376	--	996	1893	--	--	--	--
86A/86B Series	8.1	14	26	51	68	120	170	376	--	--	--	--	--	--	--
86R-100/200 Series	--	--	--	--	--	--	170	376	--	996	1893	--	--	--	--
87A-100 Series	--	--	--	--	--	--	86	104	234	375	673	1099	1902	3890	--
87A-200 Series	--	--	15	19	75	--	195	410	545	1021	2016	4837	9250	15170	22390
87A-700 Series	--	--	--	--	--	--	86	104	234	375	673	1099	1902	3890	--
87A-900 Series	--	--	15	19	75	--	195	410	545	1021	2016	4837	9250	15170	22390
87A-F00 Series	--	--	--	--	75	--	195	410	545	1021	2016	4837	--	--	--
87B-100 Series	--	--	--	--	--	--	--	--	--	375	673	1099	1902	3890	--
87J-100 Series	--	--	--	--	--	--	86	104	234	375	673	1099	1902	3890	--
87J-200 Series	--	--	15	19	75	--	195	410	545	1021	2016	4837	9250	15170	22390
87J-700 Series	--	--	--	--	--	--	86	104	234	375	673	1099	1902	3890	--
87J-900 Series	--	--	15	19	75	--	195	410	545	1021	2016	4837	9250	15170	22390
87K-100 Series	--	--	--	--	--	--	86	104	234	375	673	1099	1902	3890	--
87K-200 Series	--	--	15	19	75	--	195	410	545	1021	2016	4837	9250	15170	22390
87K-700 Series	--	--	--	--	--	--	86	104	234	375	673	1099	1902	3890	--
87K-900 Series	--	--	15	19	75	--	195	410	545	1021	2016	4837	9250	15170	22390
88A-100 Series	--	--	--	--	--	--	86	104	234	375	673	1099	1902	3890	--
88A-200 Series	--	--	15	19	75	--	195	410	545	1021	2016	4837	9250	15170	22390
88A-700 Series	--	--	--	--	--	--	86	104	234	375	673	1099	1902	3890	--
88A-900 Series	--	--	15	19	75	--	195	410	545	1021	2016	4837	9250	15170	22390
88A-F00 Series	--	--	--	--	75	--	195	410	545	1021	2016	4837	--	--	--
88B-100 Series	--	--	--	--	--	--	--	--	--	375	673	1099	1902	3890	--
89-100 Series	8.4	7.2	15	30	43	48	84	108	190	370	--	--	--	--	--
9A-100 Series	8.3	6.7	5.7	10	16	25	40	62	--	--	--	--	--	--	--
90-100 Series	8.3	6.7	5.7	10	16	25	40	62	--	--	--	--	--	--	--
92-100 Series	8.3	6.7	5.7	10	16	25	40	62	--	--	--	--	--	--	--
93-100 Series	8.3	6.7	5.7	10	16	25	40	62	--	--	--	--	--	--	--
94A-100/200 Series	6	7	19	34	50	104	268	309	629	1018	1622	--	--	--	--
96-100 Series	8.3	6.7	5.7	10	16	25	40	62	--	--	--	--	--	--	--
399-100 Series	8.4	7.2	15	30	43	48	84	108	190	370	--	--	--	--	--
489-100 Series	8.4	7.2	15	30	43	48	84	108	190	370	--	--	--	--	--

CLASS 600 (DUPLEX) ASTM A995-CD3MN & (SUPER DUPLEX) CD3MWCuN GRAPH 42

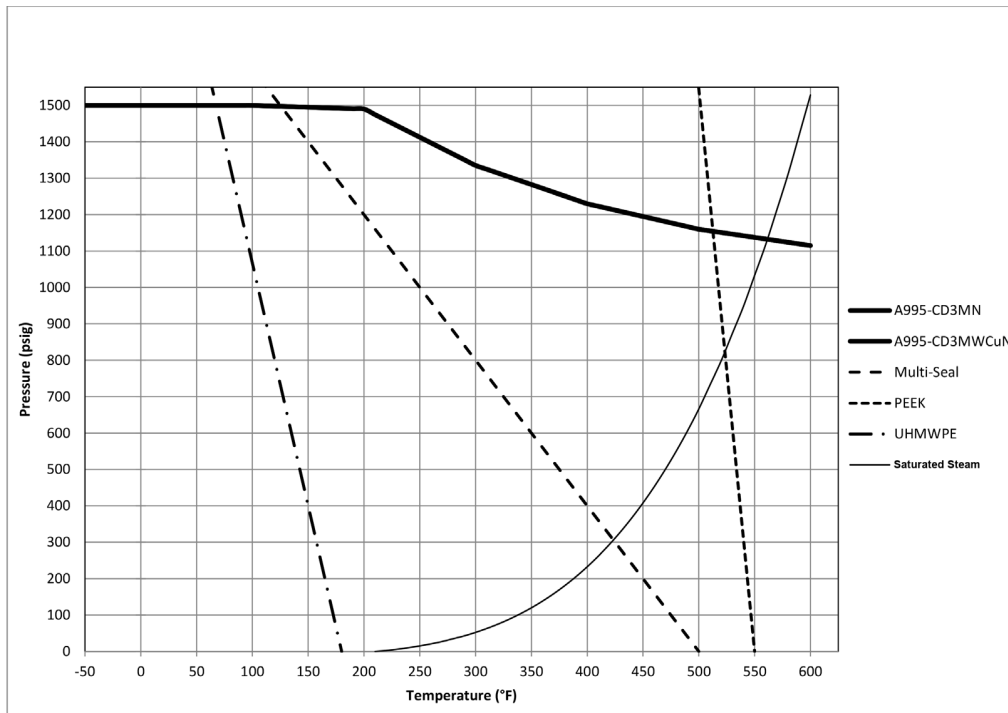

2000 CWP (DUPLEX) ASTM A995-CD3MN & (SUPER DUPLEX) CD3MWCuN GRAPH 43

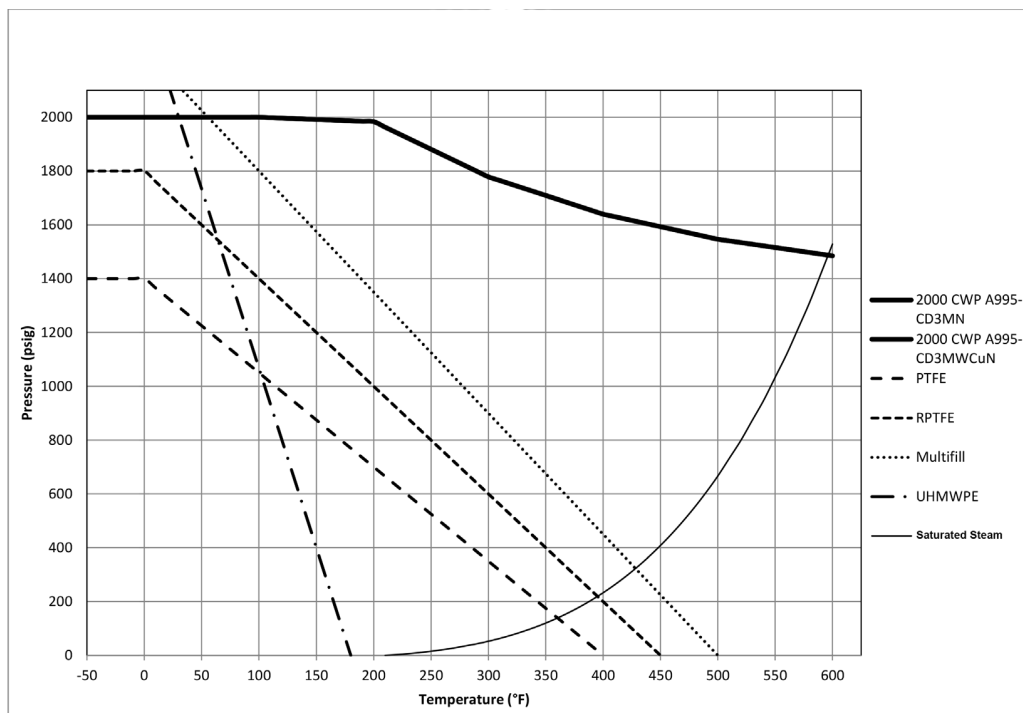

1500 CWP (DUPLEX) ASTM A995-CD3MN & (SUPER DUPLEX) CD3MWCuN GRAPH 44

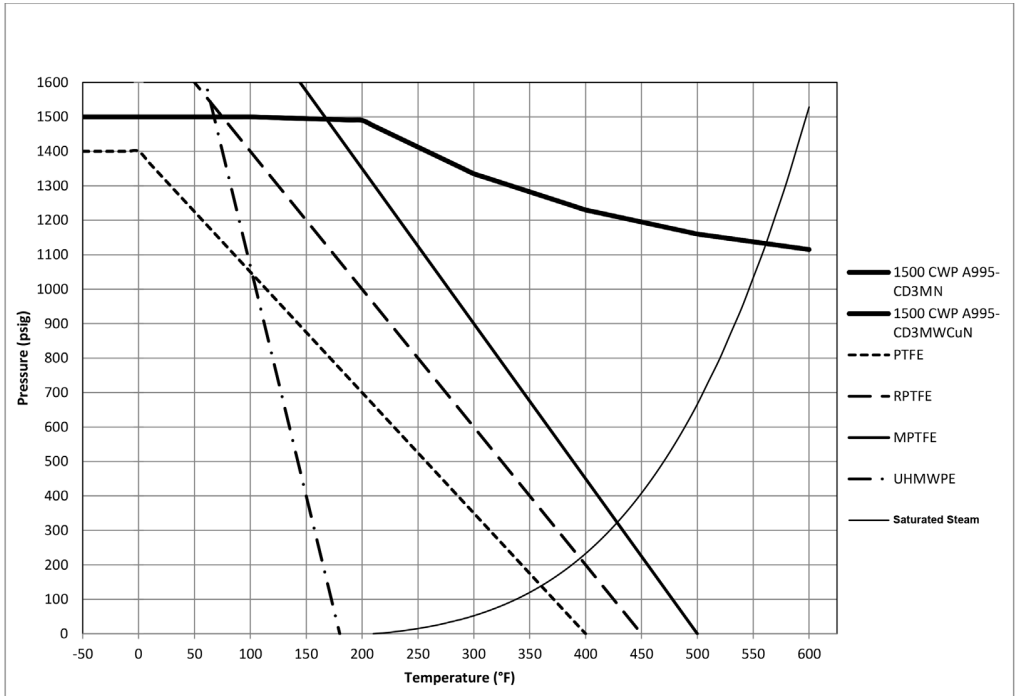

1000 CWP (DUPLEX) ASTM A995-CD3MN & (SUPER DUPLEX) CD3MWCuN GRAPH 45

