

Accessory Parts
付属部品

注意

当図面には、秘密情報など法的に守られた
情報を含んでいる場合があります。
当図面を用いての試作・量産品の製作、並びに
第三者への内容・情報の開示等を禁止します。
株式会社 ヨシタケ

(mm)

Size	L	H ₁	H	A	Flange JIS 20K RF							Weight (kg)
					d	D	C	g	t	f	n-h	
15A	146	170	398	200	15	95	70	51	14	1	4-15	15.5
20A	146	170	398	200	20	100	75	56	16	1	4-15	16.0
25A	156	175	404	226	25	125	90	67	16	1	4-19	21.0
32A	176	192	434	226	32	135	100	76	18	2	4-19	24.0
40A	196	192	434	226	40	140	105	81	18	2	4-19	24.5

Specification	
Fluid	
Inlet Press.	MPa
Reduced Press.	MPa
Temp.	℃
Flow Rate	

56	Joint	Brass	継手	C3604	2
55	Sensing Pipe	Copper	検出管	C1220	1
53	E-Ring	Stainless Steel	Eリング	SUS	1
49	Plug	Steel	プラグ	Steel	3
47	Gasket	Non Asbestos	ガスケット	Non Asbestos	0or1
42	Name Plate	Stainless Steel	ネームプレート	SUS304	1
41	Bolt	Carbon Steel	六角ボルト	SCM435	1set
40	Nut	Steel	六角ナット	Steel	4
39	Stud Bolt	Carbon Steel	植込みボルト	SCM435	4
38	Bolt	Carbon Steel	六角ボルト	SCM435	4
37	Bolt	Carbon Steel	六角ボルト	SCM435	4
36	Pipe	Copper	導管	C1220	1
35	Pipe	Copper	導管	C1220	1
34	Pipe	Copper	導管	C1220	1
33	Tee	Brass	ティー	C3771	1
32	Elbow	Brass	エルボ	C3771	1
30	Joint	Brass	継手	C3604	2
29	Plug	Steel	プラグ	Steel	2
28	Lock Nut	Steel	ロックナット	Steel	1
27	Adjusting Screw	Rolled Steel	調節ねじ	SS400	1
26	Bottom Spring Plate	Brass	下部ばね受	C3604	1
25	Top Spring Plate	Brass	上部ばね受	C3604	1
24	Spring	Piano Wire or Alloy Steel	調節ばね	SWP or SWOSC	1
23	Pilot Diaphragm	Stainless Steel	パイロットダイヤフラム	SUS301	2
22	Gasket	Copper	ガスケット	C1100	1
21	Bolt	Stainless Steel	六角ボルト	SUS	1
20	Pilot Spring Plate	Stainless Steel	先立弁ばね受	SUS304	1
19	Pilot Valve Spring	Stainless Steel	先立弁ばね	SUS304	1
18	Pilot Valve Seat	Stainless Steel	先立弁弁座	SUS420J2	1
17	Pilot Valve	Stainless Steel	先立弁弁体	SUS420J2	1
16	Gasket	Non Asbestos	ガスケット	Non Asbestos	1or2
15	Screen	Stainless Steel	スクリーン	SUS304	1
14	Spring Plate	Brass	主弁ばね受	C3604	1
13	Spring	Stainless Steel	主弁ばね	SUS304	1
12	Main Diaphragm	Stainless Steel	メインダイヤフラム	SUS301	2
11	Retainer	Brass or Bronze	リティナー	C3771 or CAC406	1
10	Guide	Stainless Steel	ガイド	SUS420J2	1
9	Main Spindle	Stainless Steel	弁軸	SUS403	1
8	Gasket	Copper	ガスケット	C1100	1
7	Main Valve Seat	Stainless Steel	弁座	SUS420J2	1
6	Main Valve	Stainless Steel	主弁	SUS420J2	1
5	Bottom Dia. Case	Ductile Cast Iron	下部ダイヤフラムケース	FCD450	1
4	Top Diaphragm Case	Ductile Cast Iron	上部ダイヤフラムケース	FCD450	1
3	Spring Chamber	Cast Iron	保護筒	FC200	1
2	Pilot Body	Ductile Cast Iron	パイロット本体	FCD450	1
1	Body	Ductile Cast Iron	本体	FCD450	1
No.	Name of Parts	Material	部品名	材質	Q.TY

TYPE GP-2000 PRESSURE REDUCING VALVE

減圧弁

Approval	H. kimura
Check	M. Murata
Drawing	S. Kato
Drawing No.	Y-767-2210-2C
Date	30 AUG.2019



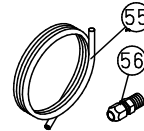
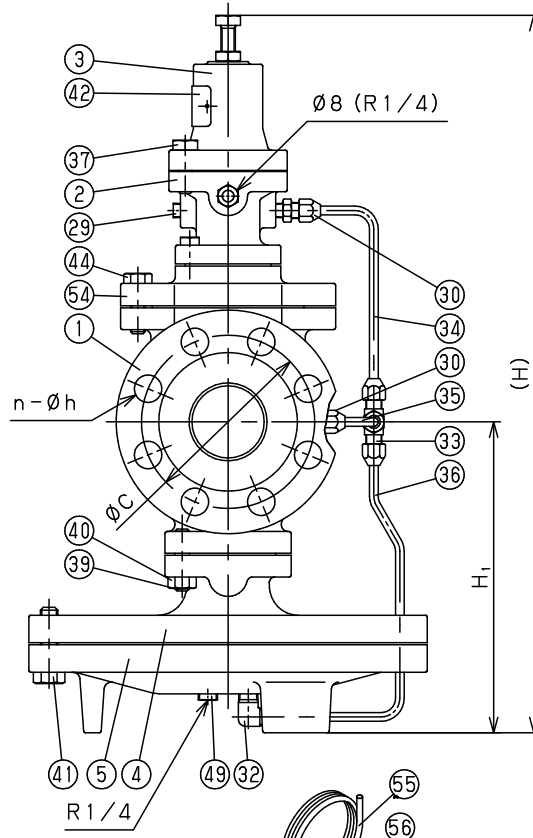
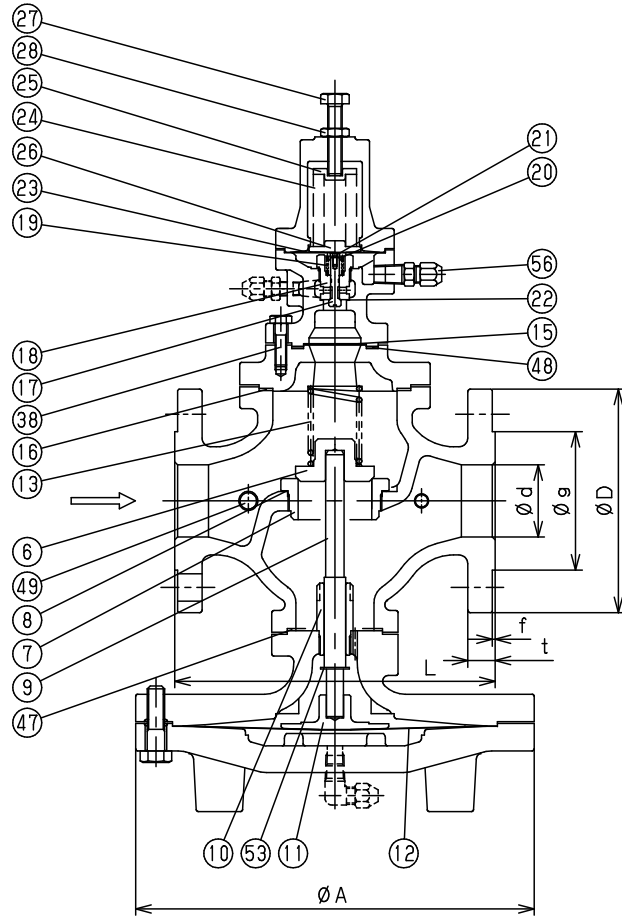

Accessory Parts
付属部品

注意
当図面には、秘密情報など法的に守られた
情報を含んでいる場合があります。
当図面を用いての試作・量産品の製作、並びに
第三者への内容・情報の開示等を禁止します。
株式会社 ヨシタケ

Size	L	H ₁	H	A	Flange JIS 20K RF							Weight (kg)
					d	D	C	g	t	f	n-h	
50A	222	216	498	276	50	155	120	96	18	2	8-19	36.0

No.	Name of Parts	Material	部品名	材質	Q.TY
56	Joint	Brass	継手	C3604	2
55	Sensing Pipe	Copper	検出管	C1220	1
54	Spacer	Ductile Cast Iron	スペーサー	FCD450	1
53	E-Ring	Stainless Steel	エリング	SUS	1
49	Plug	Steel	プラグ	Steel	3
48	Gasket	Non Asbestos	ガスケット	Non Asbestos	1
47	Gasket	Non Asbestos	ガスケット	Non Asbestos	1
44	Bolt	Carbon Steel	六角ボルト	SCM435	6
42	Name Plate	Stainless Steel	ネームプレート	SUS304	1
41	Bolt	Carbon Steel	六角ボルト	SCM435	16
40	Nut	Steel	六角ナット	Steel	4
39	Stud Bolt	Carbon Steel	植込みボルト	SCM435	4
38	Bolt	Carbon Steel	六角ボルト	SCM435	4
37	Bolt	Carbon Steel	六角ボルト	SCM435	4
36	Pipe	Copper	導管	C1220	1
35	Pipe	Copper	導管	C1220	1
34	Pipe	Copper	導管	C1220	1
33	Tee	Brass	ティー	C3771	1
32	Elbow	Brass	エルボ	C3771	1
30	Joint	Brass	継手	C3604	2
29	Plug	Steel	プラグ	Steel	2
28	Lock Nut	Steel	ロックナット	Steel	1
27	Adjusting Screw	Roller Steel	調節ねじ	SS400	1
26	Bottom Spring Plate	Brass	下部ばね受	C3604	1
25	Top Spring Plate	Brass	上部ばね受	C3604	1
24	Spring	Piano Wire or Alloy Steel	調節ばね	SWP or SWOSC	1
23	Pilot Diaphragm	Stainless Steel	パイロットダイヤフラム	SUS301	2
22	Gasket	Copper	ガスケット	C1100	1
21	Bolt	Stainless Steel	六角ボルト	SUS	1
20	Pilot Spring Plate	Stainless Steel	先立弁ばね受	SUS304	1
19	Pilot Valve Spring	Stainless Steel	先立弁ばね	SUS304	1
18	Pilot Valve Seat	Stainless Steel	先立弁弁座	SUS420J2	1
17	Pilot Valve	Stainless Steel	先立弁弁体	SUS420J2	1
16	Gasket	Non Asbestos	ガスケット	Non Asbestos	1
15	Screen	Stainless Steel	スクリーン	SUS304	1
13	Spring	Stainless Steel	主弁ばね	SUS304	1
12	Main Diaphragm	Stainless Steel	メインダイヤフラム	SUS301	2
11	Retainer	Brass or Bronze	リティナー	C3771 or CAC406	1
10	Guide	Stainless Steel	ガイド	SUS420J2	1
9	Main Spindle	Stainless Steel	弁軸	SUS403	1
8	Gasket	Copper	ガスケット	C1100	1
7	Main Valve Seat	Stainless Steel	弁座	SUS420J2	1
6	Main Valve	Stainless Steel	主弁	SUS420J2	1
5	Bottom Dia. Case	Ductile Cast Iron	下部ダイヤフラムケース	FCD450	1
4	Top Diaphragm Case	Ductile Cast Iron	上部ダイヤフラムケース	FCD450	1
3	Spring Chamber	Cast Iron	保護筒	FC200	1
2	Pilot Body	Ductile Cast Iron	パイロット本体	FCD450	1
1	Body	Ductile Cast Iron	本体	FCD450	1

Specification	
Fluid	
Inlet Press.	MPa
Reduced Press.	MPa
Temp.	℃
Flow Rate	

TYPE GP-2000 PRESSURE REDUCING VALVE
減圧弁

Approval	H. Kimura
Check	M. Murata
Drawing	S. Kato
Drawing No.	Y-767-2210-3C
Date	30 AUG.2019



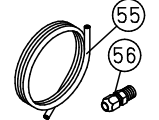
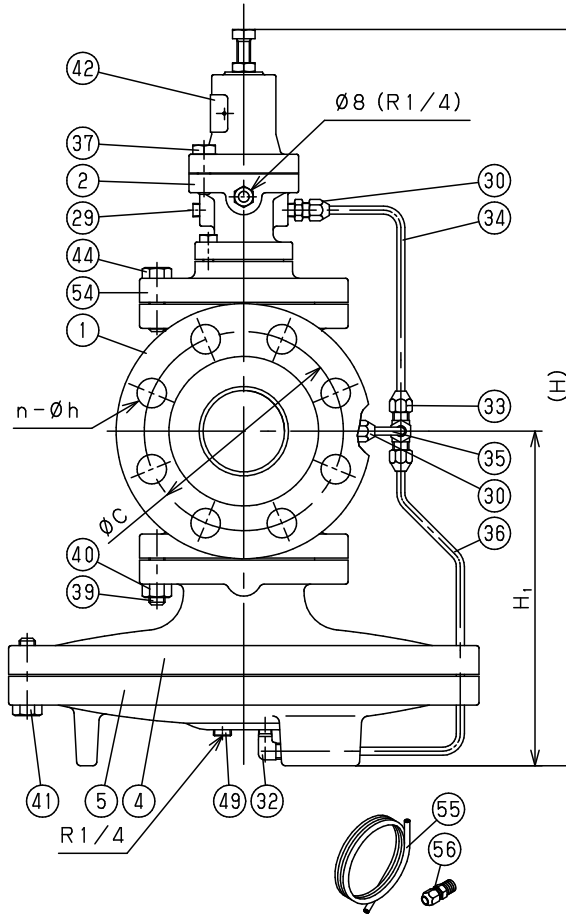
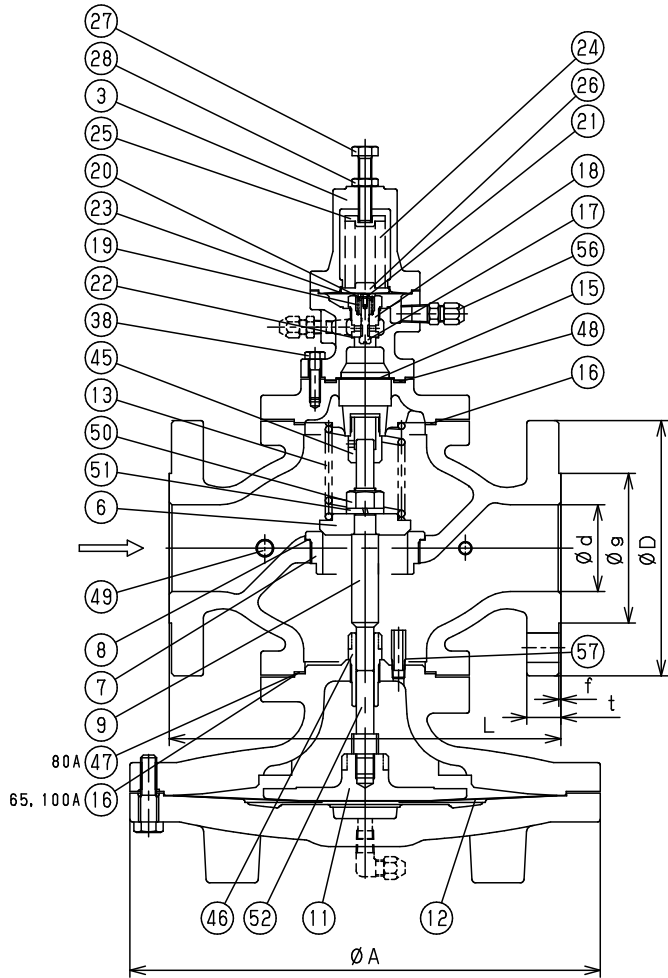

Accessory Parts
付属部品

No.	Name of Parts	Material	部品名	材質	Q.TY
57	Pipe	Carbon Stee Pipe	パイプ	SGP	1
56	Joint	Brass	継手	C3604	2
55	Sensing Pipe	Copper	検出管	C1220	1
54	Spacer	Ductile Cast Iron	スペーサー	FCD450	1
52	Adaptor	Stainless Steel	アダプター	SUS403	1
51	Sprig Washer	Stainless Steel	ばね座金	SUS	1
50	Nut	Stainless Steel	六角ナット	SUS	1
49	Plug	Steel	プラグ	Steel	3
48	Gasket	Non Asbestos	ガスケット	Non Asbestos	1
47	Gasket	Non Asbestos	ガスケット	Non Asbestos	0or1
46	Guide B	Stainless Steel	ガイド B	SUS420J2	1
45	Guide A	Stainless Steel	ガイド A	SUS420J2	1
44	Bolt	Carbon Steel	六角ボルト	SCM435	8
42	Name Plate	Stainless Steel	ネームプレート	SUS304	1
41	Bolt	Carbon Steel	六角ボルト	SCM435	18or20
40	Nut	Steel	六角ナット	Steel	8
39	Stud Bolt	Carbon Steel	植込みボルト	SCM435	8
38	Bolt	Carbon Steel	六角ボルト	SCM435	4
37	Bolt	Carbon Steel	六角ボルト	SCM435	4
36	Pipe	Copper	導管	C1220	1
35	Pipe	Copper	導管	C1220	1
34	Pipe	Copper	導管	C1220	1
33	Tee	Brass	ティー	C3771	1
32	Elbow	Brass	エルボ	C3771	1
30	Joint	Brass	継手	C3604	2
29	Plug	Steel	プラグ	Steel	2
28	Lock Nut	Steel	ロックナット	Steel	1
27	Adjusting Screw	Rolled Steel	調節ねじ	SS400	1
26	Bottom Spring Plate	Brass	下部ばね受	C3604	1
25	Top Spring Plate	Brass	上部ばね受	C3604	1
24	Spring	Piano wire or Alloy Steel	調節ばね	SWPA or SWOSC	1
23	Pilot Diaphragm	Stainless Steel	パイロットダイヤフラム	SUS301	2
22	Gasket	Copper	ガスケット	C1100	1
21	Bolt	Stainless Steel	六角ボルト	SUS	1
20	Pilot Spring Plate	Stainless Steel	先立弁ばね受	SUS304	1
19	Pilot Valve Spring	Stainless Steel	先立弁ばね	SUS304	1
18	Pilot Valve Seat	Stainless Steel	先立弁弁座	SUS420J2	1
17	Pilot Valve	Stainless Steel	先立弁弁体	SUS420J2	1
16	Gasket	Non Asbestos	ガスケット	Non Asbestos	1or2
15	Screen	Stainless Steel	スクリーン	SUS304	1
13	Spring	Stainless Steel	主弁ばね	SUS304	1
12	Main Diaphragm	Stainless Steel	メインダイヤフラム	SUS301	2
11	Retainer	Bronze or Brass	リティナー	CAC406 or C3771	1
9	Main Spindle	Stainless Steel	弁軸	SUS403	1
8	Gasket	Copper	ガスケット	C1100	1
7	Main Valve Seat	Stainless Steel	弁座	SUS420J2	1
6	Main Valve	Stainless Steel	主弁	SUS420J2	1
5	Bottom Dia. Case	Ductile Cast Iron	下部ダイヤフラムケース	FCD450	1
4	Top Diaphragm Case	Ductile Cast Iron	上部ダイヤフラムケース	FCD450	1
3	Spring Chamber	Cast Iron	保護筒	FC200	1
2	Pilot Body	Ductile Cast Iron	パイロット本体	FCD450	1
1	Body	Ductile Cast Iron	本体	FCD450	1

注意

当図面には、秘密情報など法的に守られた情報を含んでいる場合があります。当図面を用いての試作・量産品の製作、並びに第三者への内容・情報の開示等を禁止します。
株式会社 ヨシタケ

Size	L	H ₁	H	A	Flange JIS 20K RF							Weight (kg)
					d	D	C	g	t	f	n-h	
65A	282	251	552	352	65	175	140	116	20	2	8-19	64.5
80A	302	264	575	352	80	200	160	132	22	2	8-23	71.0
100A	342	321	658	401	100	225	185	160	24	2	8-23	110.5

Specification	
Fluid	
Inlet Press.	MPa
Reduced Press.	MPa
Temp.	℃
Flow Rate	

TYPE GP-2000 PRESSURE REDUCING VALVE
減圧弁

Approval	H. Iwamoto
Check	K. Takenaka
Drawing	S. Harita
Drawing No.	Y-767-2210-1D
Date	21 APR. 2017



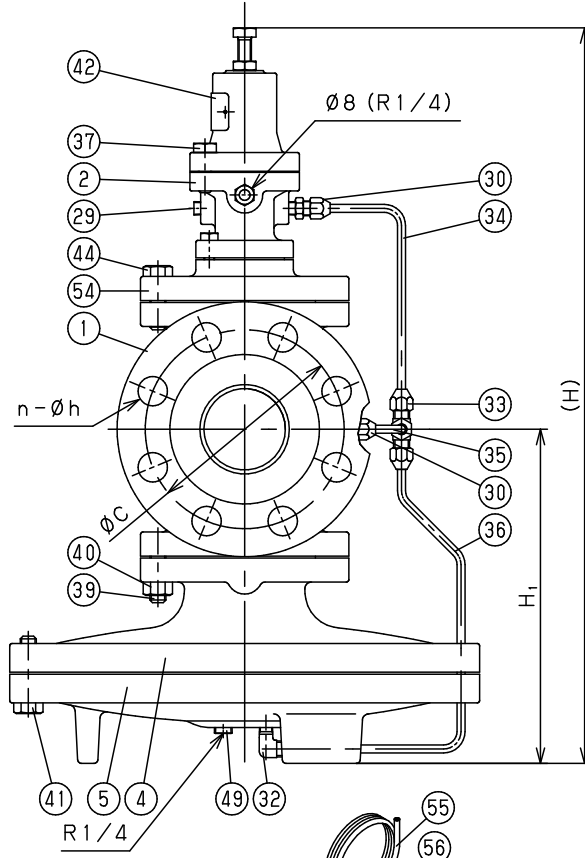
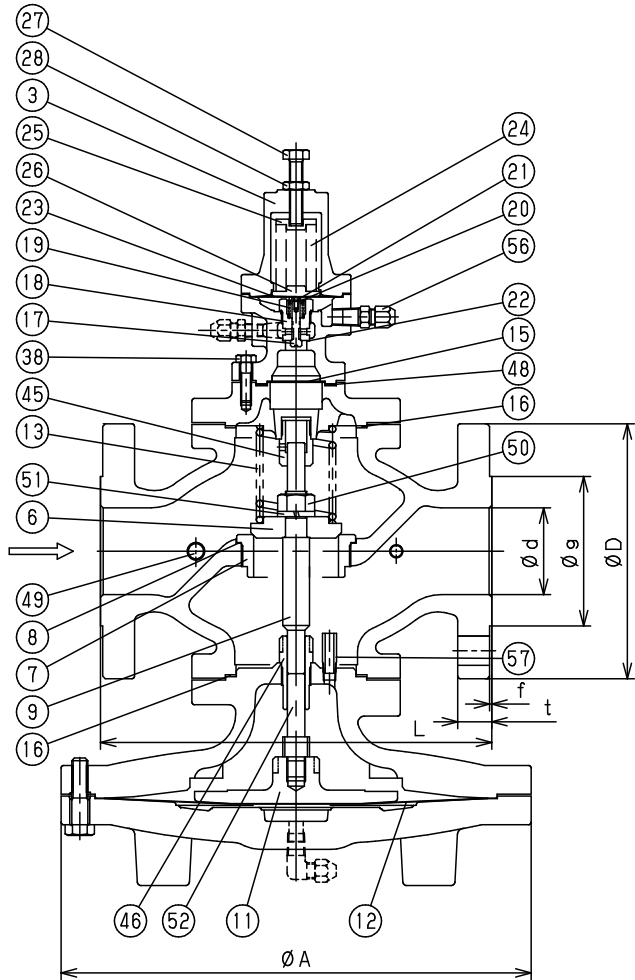

57	Pipe	Carbon Steel Pipe	パイプ	SGP	1
56	Joint	Brass	継手	C3604	2
55	Sensing Pipe	Copper	検出管	C1220	1
54	Spacer	Ductile Cast Iron	スペーサー	FCD450	1
52	Adaptor	Stainless Steel	アダプター	SUS403	1
51	Sprig Washer	Stainless Steel	ばね座金	SUS	1
50	Nut	Stainless Steel	六角ナット	SUS	1
49	Plug	Steel	プラグ	Steel	3
48	Gasket	Non Asbestos	ガスケット	Non Asbestos	1
46	Guide B	Stainless Steel	ガイド B	SUS420J2	1
45	Guide A	Stainless Steel	ガイド A	SUS420J2	1
44	Bolt	Carbon Steel	六角ボルト	SCM435	8
42	Name Plate	Stainless Steel	ネームプレート	SUS304	1
41	Bolt	Carbon Steel	六角ボルト	SCM435	20
40	Nut	Steel	六角ナット	Steel	8
39	Stud Bolt	Carbon Steel	挿込みボルト	SCM435	8
38	Bolt	Carbon Steel	六角ボルト	SCM435	4
37	Bolt	Carbon Steel	六角ボルト	SCM435	4
36	Pipe	Copper	導管	C1220	1
35	Pipe	Copper	導管	C1220	1
34	Pipe	Copper	導管	C1220	1
33	Tee	Brass	ティー	C3771	1
32	Elbow	Brass	エルボ	C3771	1
30	Joint	Brass	継手	C3604	2
29	Plug	Steel	プラグ	Steel	2
28	Lock Nut	Steel	ロックナット	Steel	1
27	Adjusting Screw	Rolled Steel	調節ねじ	SS400	1
26	Bottom Spring Plate	Brass	下部ばね受	C3604	1
25	Top Spring Plate	Brass	上部ばね受	C3604	1
24	Spring	Alloy Steel	調節ばね	SW5C	1
23	Pilot Diaphragm	Stainless Steel	パイロットダイヤフラム	SUS301	2
22	Gasket	Copper	ガスケット	C1100	1
21	Bolt	Stainless Steel	六角ボルト	SUS	1
20	Pilot Spring Plate	Stainless Steel	先立弁ばね受	SUS304	1
19	Pilot Valve Spring	Stainless Steel	先立弁ばね	SUS304	1
18	Pilot Valve Seat	Stainless Steel	先立弁弁座	SUS420J2	1
17	Pilot Valve	Stainless Steel	先立弁弁体	SUS420J2	1
16	Gasket	Non Asbestos	ガスケット	Non Asbestos	2
15	Screen	Stainless Steel	スクリーン	SUS304	1
13	Spring	Stainless Steel	主弁ばね	SUS304	1
12	Main Diaphragm	Stainless Steel	メインダイヤフラム	SUS301	2
11	Retainer	Bronze	リティナー	CAC406	1
9	Main Spindle	Stainless Steel	弁軸	SUS403	1
8	Gasket	Copper	ガスケット	C1100	1
7	Main Valve Seat	Stainless Steel	弁座	SUS420J2	1
6	Main Valve	Stainless Steel	主弁	SUS420J2	1
5	Bottom Dia. Case	Ductile Cast Iron	下部ダイヤフラムケース	FCD450	1
4	Top Diaphragm Case	Ductile Cast Iron	上部ダイヤフラムケース	FCD450	1
3	Spring Chamber	Cast Iron	保護筒	FC200	1
2	Pilot Body	Ductile Cast Iron	パイロット本体	FCD450	1
1	Body	Ductile Cast Iron	本体	FCD450	1
No.	Name of Parts	Material	部品名	材質	Q.TY

注意
当図面には、秘密情報など法的に守られた
情報を含んでいる場合があります。
当図面を用いての試作・量産品の製作、並びに
第三者への内容・情報の開示等を禁止します。
株式会社 ヨシタケ

Size	L	H ₁	H	A	Flange JIS 20K RF							Weight (kg)
					d	D	C	g	t	f	n-h	
125A	400	321	658	401	125	270	225	195	26	2	8-25	115.0

Specification	
Fluid	
Inlet Press.	MPa
Reduced Press.	MPa
Temp.	℃
Flow Rate	

TYPE GP-2000
PRESSURE REDUCING VALVE
減圧弁

Approval	H. Iwamoto
Check	K. Takenaka
Drawing	S. Harita
Drawing No.	Y-767-2210-4B
Date	21 APR. 2017

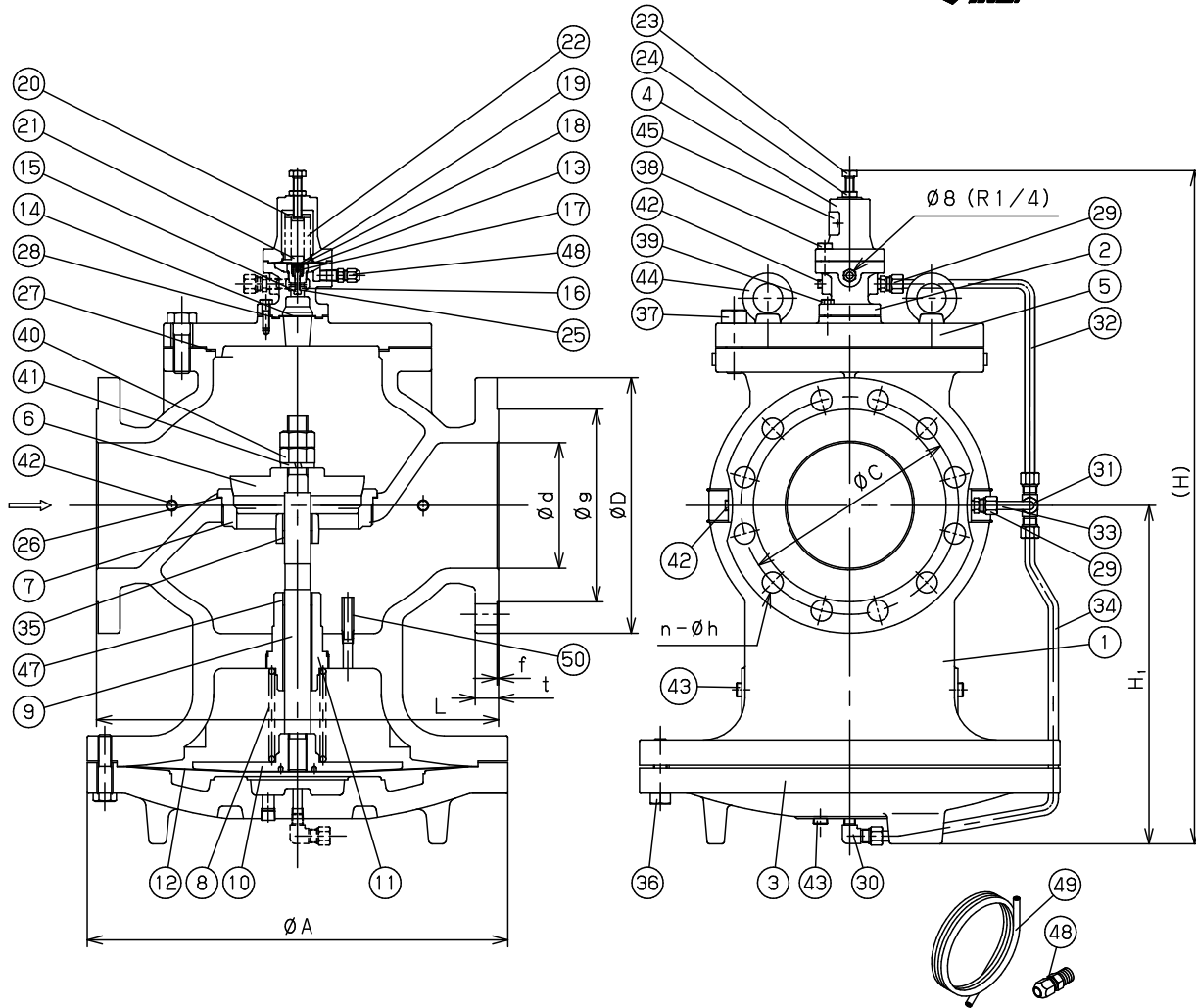

50	Pipe	Carbon Steel Pipe	パイプ	SGP	1
49	Pipe	Copper	外部導管	C1220	1
48	Joint	Brass	外部継手	C3604	2
47	Bush	PTFE&SPC	ブッシュ	PTFE&SPC	1
45	Name Plate	Stainless Steel	ネームプレート	SUS304	1
44	Eyebolt	Rolled Steel	アイボルト	SS400	2
43	Plug	Steel	プラグ	Steel	3
42	Plug	Steel	プラグ	Steel	4
41	Spring Washer	Stainless Steel	ばね座金	SUS	1
40	Nut	Stainless Steel	六角ナット	SUS	2
39	Bolt	Carbon Steel	六角ボルト	SCM435	4
38	Bolt	Carbon Steel	六角ボルト	SCM435	4
37	Bolt	Carbon Steel	六角ボルト	SCM435	8
36	Bolt	Carbon Steel	六角ボルト	SCM435	24
35	Bush	PTFE&SPC	ブッシュ	PTFE&SPC	1
34	Pipe	Copper	導管	C1220	1
33	Pipe	Copper	導管	C1220	1
32	Pipe	Copper	導管	C1220	1
31	Tee	Brass	ティー	C3771	1
30	Elbow	Brass	エルボ	C3771	1
29	Joint	Brass	継手	C3604	2
28	Gasket	Non Asbestos	ガスケット	Non Asbestos	1
27	Gasket	Non Asbestos	ガスケット	Non Asbestos	1
26	Gasket	Copper	ガスケット	C1100	1
25	Gasket	Copper	ガスケット	C1100	1
24	Lock Nut	Steel	ロックナット	Steel	1
23	Adjusting Screw	Rolled Steel	調節ねじ	SS400	1
22	Spring	Alloy Steel	調節ばね	SWOSC	1
21	Bottom Spring Plate	Brass	下部ばね受	C3604	1
20	Top Spring Plate	Brass	上部ばね受	C3604	1
19	Bolt	Stainless Steel	六角ボルト	SUS	1
18	Pilot Spring Plate	Stainless Steel	先立弁ばね受	SUS304	1
17	Pilot Valve Spring	Stainless Steel	先立弁ばね	SUS304	1
16	Pilot Valve Seat	Stainless Steel	先立弁弁座	SUS420J2	1
15	Pilot Valve	Stainless Steel	先立弁弁体	SUS420J2	1
14	Screen	Stainless Steel	スクリーン	SUS304	1
13	Pilot Diaphragm	Stainless Steel	パイロットダイヤフラム	SUS301	2
12	Main Diaphragm	Stainless Steel	メインダイヤフラム	SUS301	2
11	Guide	Stainless Steel	ガイド	SUS403	1
10	Retainer	Ductile Cast Iron	リティナー	FCD450	1
9	Main Spindle	Stainless Steel	弁棒	SUS303	1
8	Spring	Stainless Steel	主弁ばね	SUS304	1
7	Main Valve Seat	Stainless Steel	弁座	SCS2	1
6	Main Valve	Stainless Steel	主弁	SUS420J2	1
5	Spacer	Ductile Cast Iron	スペーサー	FCD450	1
4	Spring Chamber	Cast Iron	保護筒	FC200	1
3	Bottom Diaphragm Case	Ductile Cast Iron	下部ダイヤフラムケース	FCD450	1
2	Pilot Body	Ductile Cast Iron	パイロット本体	FCD450	1
1	Body	Ductile Cast Iron	本体	FCD450	1
No.	Name of Parts	Material	部品名	材質	Q.TY

注意
当図面には、秘密情報など法的に守られた
情報を含んでいる場合があります。
当図面を用いての試作・量産品の製作、並びに
第三者への内容・情報の開示等を禁止します。
株式会社 ヨシタケ

Size	L	H ₁	H	A	Flange JIS 20K RF							Weight (kg)
					d	D	C	g	t	f	n-h	
150A	465	414	814	502	150	305	260	230	28	2	12-25	234
200A	469	414	814	502	200	350	305	275	30	2	12-25	242

Specification	
Fluid	
Inlet Press.	MPa
Reduced Press.	MPa
Temp.	℃
Flow Rate	

TYPE GP-2000 PRESSURE REDUCING VALVE
減圧弁

Approval	H. Iwamoto
Check	K. Takenaka
Drawing	S. Harita
Drawing No.	Y-767-2210-17A
Date	21 APR. 2017

