

Specification	
Fluid	
Max. Press.	MPa
Max. Temp.	℃
Expansion Amt.	+20, -50 mm

No.	Name of Parts	Material	部品名	材質	Q. TY
12	Anchor Base	Rolled Steel	アンカーベース	SS400	1set
11	Outside Pipe	Rolled mild Steel	外筒	SPHC	1
10	Bar	Rolled Steel	丸棒	SS400	2or3
9	Middle Ring	Rolled Steel	中間リング	SS400	2
8	Inside Pipe	Stainless Steel	内筒	SUS316L	1
7	Bellows	Stainless Steel	ベローズ	SUS316L	2
6	Ring	Rolled Steel	リング	SS400	2
5	Shipping Bolt	Rolled Steel	SHIPPING ボルト	SS400	6set
4	Shipping Washer	Rolled mild Steel	SHIPPING 座金	SPHC	6
3	Guide Pipe	Carbon Steel Tube	ガイドパイプ	STK	2
2	Flange	Rolled Steel	フランジ	SS400	2
1	Packing Seat	Stainless Steel	パッキンシート	SUS316L	2

※ ④ SHIPPING 座金、⑤ SHIPPING ボルトは、配管（固定点及びガイド施工）後取り外しの事。

Be sure to remove the ④Shipping Washer and ⑤Shipping Bolt after installation (Fixing point and guide execution).

Size	L	使用最大長さ Max. operating Length	使用最小長さ Min. operating Length	最大伸縮長さ Max. Expansion Length	Do	アンカーベース寸法 Anchor Base Dimension							Flange JIS 10K				Weight (kg)	
						H	J	K	A	B	C <sub>1</sub>	h <sub>1</sub>	D	C	G	t		n-h
20A	680	700	630	70	58.2	100	100	60	135	95	3.2	12	100	75	56	14	4-15	4.6
25A	680	700	630	70	58.2	100	100	60	135	95	3.2	12	125	90	67	14	4-19	5.5
32A	680	700	630	70	73.2	120	100	70	135	105	3.2	12	135	100	76	16	4-19	6.7
40A	680	700	630	70	73.2	120	100	70	135	105	3.2	12	140	105	81	16	4-19	7.0
50A	680	700	630	70	98.2	130	100	80	140	120	3.2	15	155	120	96	16	4-19	9.8
65A	780	800	730	70	109.7	140	120	100	160	140	4.0	15	175	140	116	18	4-19	11.1
80A	780	800	730	70	135.7	150	120	110	160	150	4.0	15	185	150	126	18	8-19	12.6
100A	880	900	830	70	161.7	170	120	130	160	175	4.0	19	210	175	151	18	8-19	16.3

TYPE EB-2J EXPANSION JOINT

伸縮管継手

Approval	H. Iwamoto
Check	Y. Aoyama
Drawing	S. Kanematsu
Drawing No.	Y-089-6099-1A
Date	1 NOV. 2012



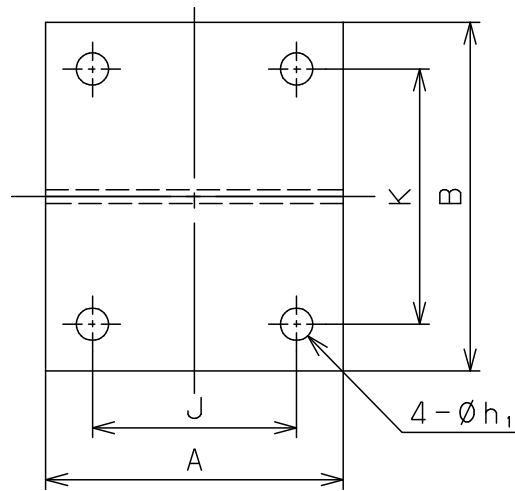
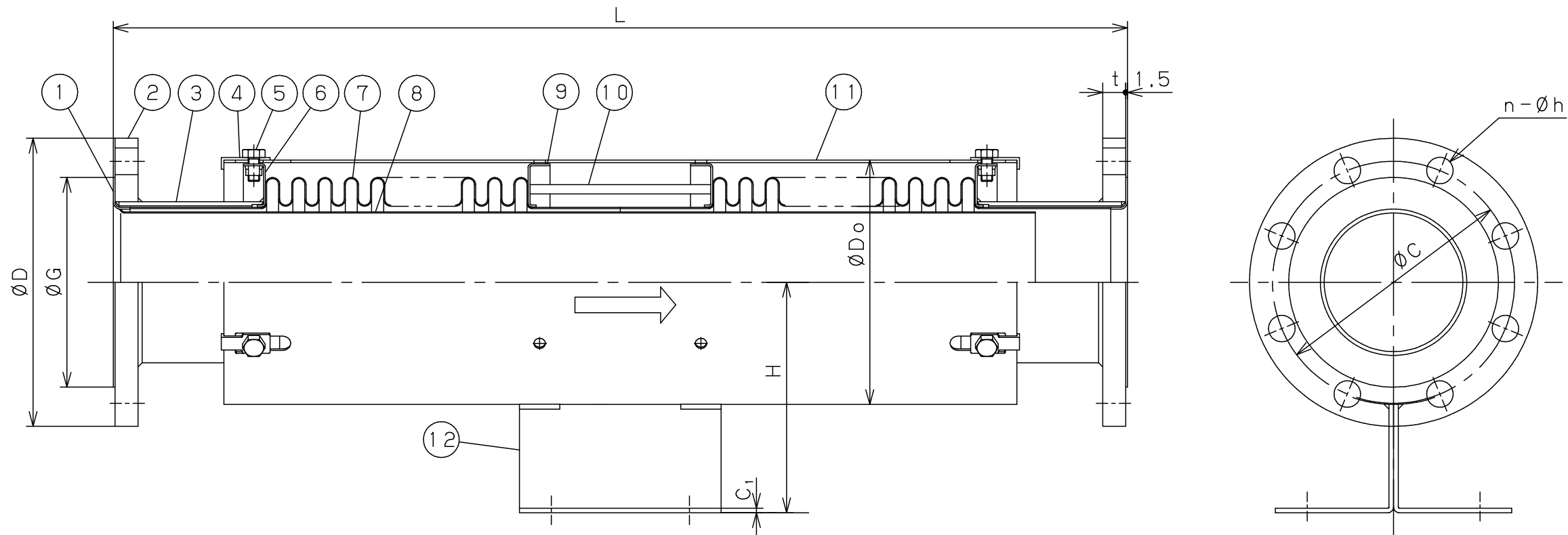

12	Anchor Base	Rolled Steel	アンカーベース	SS400	1set
11	Outside Pipe	Rolled mild Steel	外筒	SPHC	1
10	Bar	Rolled Steel	丸棒	SS400	3
9	Middle Ring	Rolled Steel	中間リング	SS400	2
8	Inside Pipe	Stainless Steel	内筒	SUS316L	1
7	Bellows	Stainless Steel	ベローズ	SUS316L	2
6	Ring	Rolled Steel	リング	SS400	2
5	Shipping Bolt	Rolled Steel	SHIPPINGボルト	SS400	6set
4	Shipping Washer	Rolled mild Steel	SHIPPING座金	SPHC	6
3	Guide Pipe	Carbon Steel Tube	ガイドパイプ	STK	2
2	Flange	Rolled Steel	フランジ	SS400	2
1	Packing Seat	Stainless Steel	パッキンシート	SUS316L	2
No.	Name of Parts	Material	部品名	材質	Q. TY

Specification	
Fluid	
Max. Press.	MPa
Max. Temp.	℃
Expansion Amt.	+20, -50 mm

※ ④ SHIPPING座金、⑤ SHIPPINGボルトは、配管（固定点及びガイド施工）後取り外しの事。

Be sure to remove the ④Shipping Washer and ⑤Shipping Bolt after installation (Fixing point and guide execution). (mm)

Size	L	使用最大長さ Max. operating Length	使用最小長さ Min. operating Length	最大伸縮長さ Max. Expansion Length	Do	アンカーベース寸法 Anchor Base Dimension							Flange JIS 10K					Weight (kg)
						H	J	K	A	B	C <sub>1</sub>	h <sub>1</sub>	D	C	G	t	n-h	
125A	880	900	830	70	212.1	200	120	150	175	205	4.0	19	250	210	182	20	8-23	34.5
150A	930	950	880	70	235.1	220	160	180	215	235	4.5	23	280	240	212	22	8-23	41.6

TYPE EB-2J EXPANSION JOINT  
伸縮管継手

Approval	H. Iwamoto
Check	Y. Aoyama
Drawing	S. Kanematsu
Drawing No.	Y-089-6099-2A
Date	1 NOV. 2012



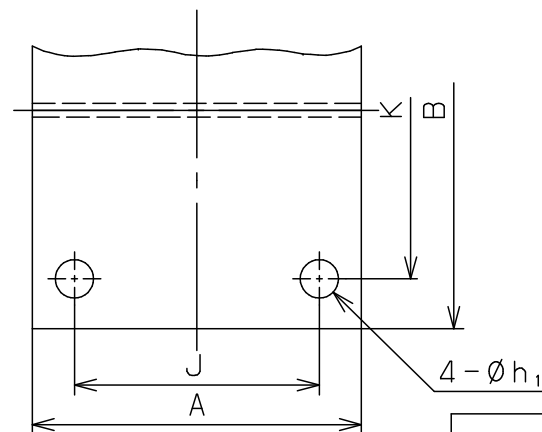
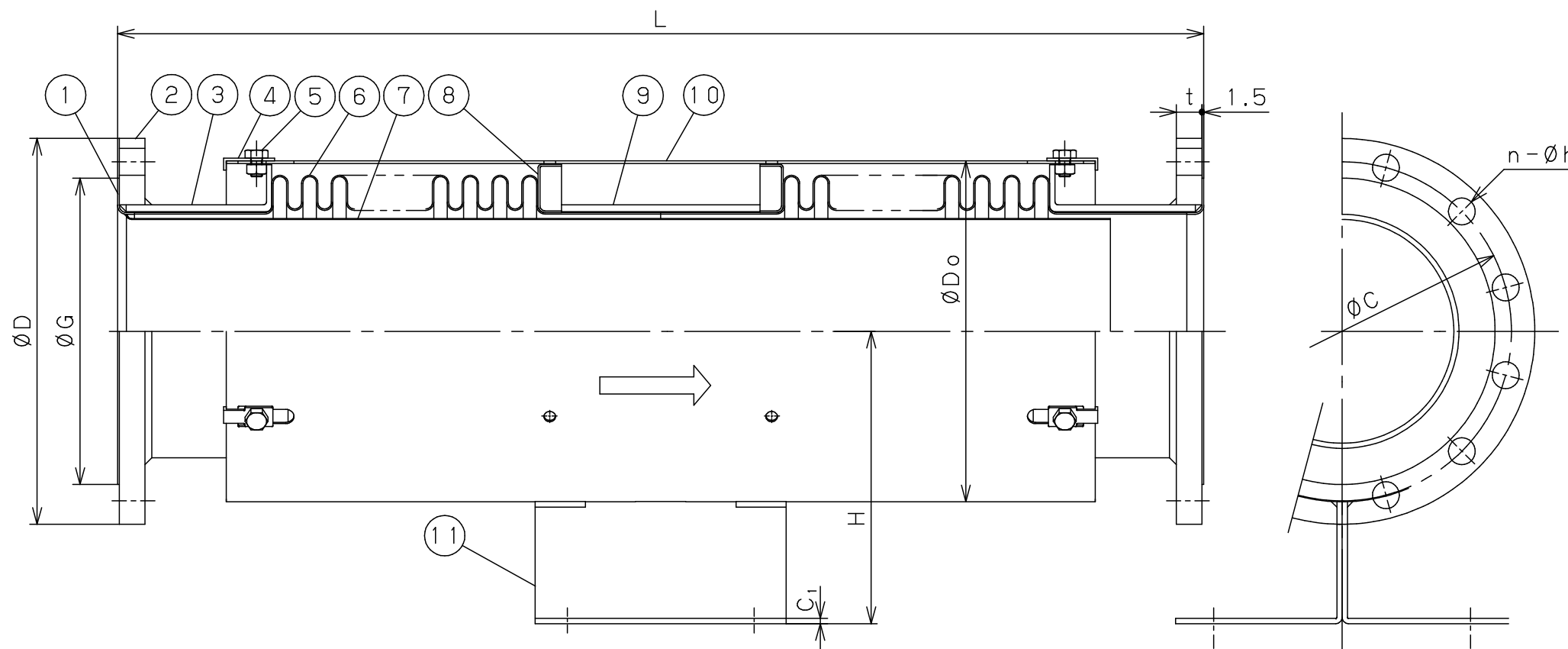

11	Anchor Base	Rolled Steel	アンカーベース	SS400	1set
10	Outside Pipe	Rolled Steel	外筒	SS400	1
9	Reinforce Pipe	Rolled Steel	補強パイプ	SS400	1set
8	Middle Ring	Rolled Steel	中間リング	SS400	2
7	Inside Pipe	Stainless Steel	内筒	SUS316L	1
6	Bellows	Stainless Steel	ベローズ	SUS316L	2
5	Shipping Bolt	Rolled Steel	SHIPPINGボルト	SS400	6set
4	Shipping Washer	Rolled Steel	SHIPPING座金	SS400	6
3	Guide Pipe	Carbon Steel Pipe	ガイドパイプ	SGP	2
2	Flange	Rolled Steel	フランジ	SS400	2
1	Packing Seat	Stainless Steel	パッキンシート	SUS316L	2
No.	Name of Parts	Material	部品名	材質	Q. TY

Specification	
Fluid	
Max. Press.	MPa
Max. Temp.	℃
Expansion Amt.	+20, -50 mm

※ ④ SHIPPING座金、⑤ SHIPPINGボルトは、配管（固定点及びガイド施工）後取り外しの事。

Be sure to remove the ④Shipping Washer and ⑤Shipping Bolt after installation (Fixing point and guide execution). (mm)

Size	L	使用最大長さ Max. operating Length	使用最小長さ Min. operating Length	最大伸縮長さ Max. Expansion Length	Do	アンカーベース寸法 Anchor Base Dimension						Flange JIS 10K					Weight (kg)	
						H	J	K	A	B	C <sub>1</sub>	h <sub>1</sub>	D	C	G	t		n-h
200A	930	950	880	70	291.6	250	160	220	215	285	4.5	25	330	290	262	22	12-23	59.9
250A	980	1000	930	70	332.6	300	180	280	255	375	4.5	27	400	355	324	24	12-25	83.0

TYPE EB-2J EXPANSION JOINT  
伸縮管継手

Approval	H. Iwamoto
Check	Y. Aoyama
Drawing	S. Kanematsu
Drawing No.	Y-089-6099-3A
Date	1 NOV. 2012

