

注意

当図面には、秘密情報など法的に守られた情報を含んでいる場合があります。  
 当図面を用いての試作・量産品の製作、並びに第三者への内容・情報の開示等を禁止します。  
 株式会社 ヨシタケ

Specification	
Fluid	
Max. Press.	MPa
Max. Temp.	℃
Expansion Amt.	+10, -25 mm

※⑩ SHIPPING 座金、⑪ SHIPPING ボルトは、配管（固定点及びガイド施工）後取り外しの事。  
 Be sure to remove the ⑩ Shipping Washer and ⑪ Shipping Bolt after installation  
 (Fixing point and guide execution).

No.	Name of Parts	Material	部品名	材質	Q. TY
12	Guide Pipe	Carbon Steel Tube	ガイドパイプ	STK	1
11	Shipping Bolt	Rolled Steel	SHIPPING ボルト	SS400	3set
10	Shipping Washer	Rolled Mild Steel	SHIPPING 座金	SPHC	3
9	Ring	Rolled Steel	リング	SS400	1
8	Inside Pipe	Stainless Steel	内筒	SUS316L	1
7	Outside Pipe	Rolled Mild Steel	外筒	SPHC	1
6	Control Ring	Rolled Steel	コントロールリング	SS400	1set
5	Bellows	Stainless Steel	ベローズ	SUS316L	1
4	Ring	Rolled Steel	リング	SS400	1
3	Guide Pipe	Carbon Steel Tube	ガイドパイプ	STK	1
2	Flange	Rolled Steel	フランジ	SS400	2
1	Packing Seat	Stainless Steel	パッキングシート	SUS316L	2

Size	L	使用最大長さ Max. operating Length	使用最小長さ Min. operating Length	最大伸縮長さ Max. Expansion Length	D <sub>0</sub>	Flange JIS 20K RF						Weight (kg)
						D	C	G	t	f	n-h	
20A	365	375	340	35	58.2	100	75	56	16	1	4-15	2.7
25A	365	375	340	35	58.2	125	90	67	16	1	4-19	3.6
32A	365	375	340	35	73.2	135	100	76	18	2	4-19	4.4
40A	365	375	340	35	73.2	140	105	81	18	2	4-19	5.3
50A	365	375	340	35	98.2	155	120	96	18	2	8-19	6.8
65A	415	425	390	35	109.7	175	140	116	20	2	8-19	9.5
80A	415	425	390	35	135.7	200	160	132	22	2	8-23	13.1
100A	415	425	390	35	161.7	225	185	160	24	2	8-23	19.0

TYPE EB-11 EXPANSION JOINT  
 伸縮管継手

Approval	H. Kimura
Check	M. Murata
Drawing	S. Kato
Drawing No.	Y-175-6010-4A
Date	29 JUN. 2018

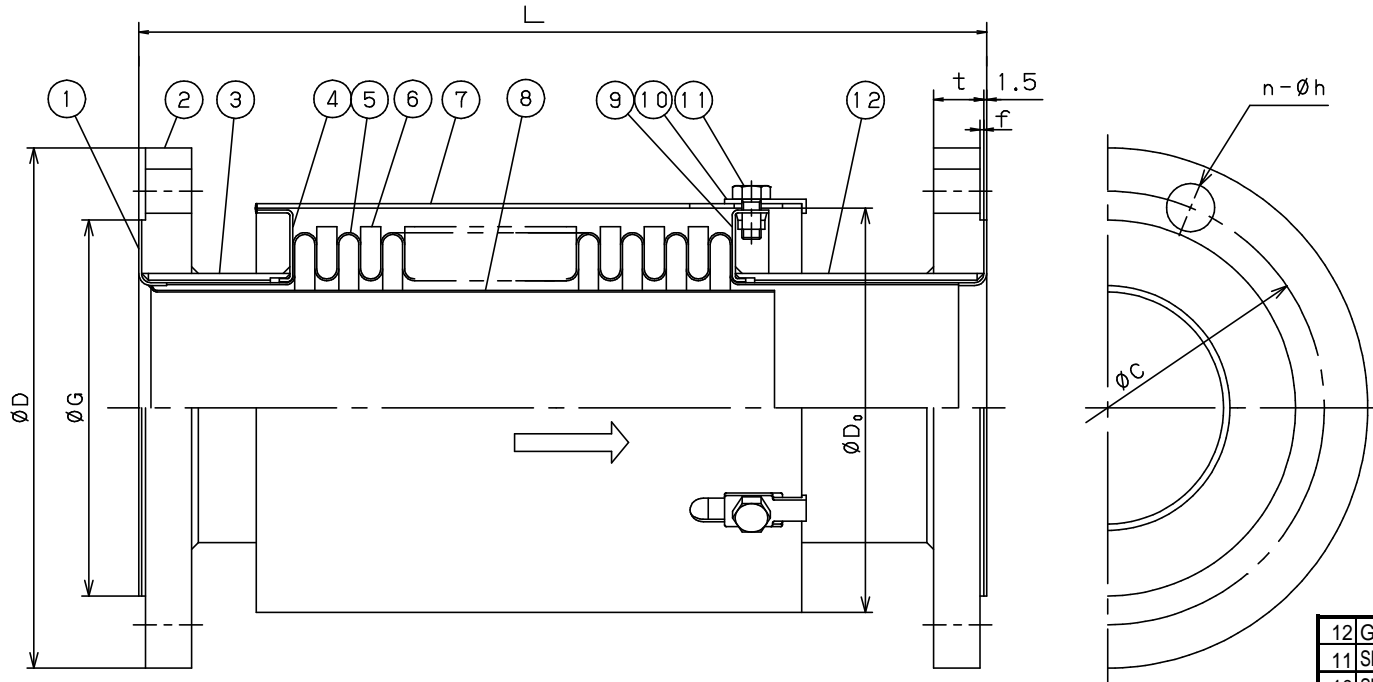

12	Guide Pipe	Carbon Steel Tube	ガイドパイプ	STK	1
11	Shipping Bolt	Rolled Steel	SHIPPINGボルト	SS400	3set
10	Shipping Washer	Rolled Mild Steel	SHIPPING座金	SPHC	3
9	Ring	Rolled Steel	リング	SS400	1
8	Inside Pipe	Stainless Steel	内筒	SUS316L	1
7	Outside Pipe	Rolled Mild Steel	外筒	SPHC	1
6	Control Ring	Rolled Steel	コントロールリング	SS400	1set
5	Bellows	Stainless Steel	ベローズ	SUS316L	1
4	Ring	Rolled Steel	リング	SS400	1
3	Guide Pipe	Carbon Steel Tube	ガイドパイプ	STK	1
2	Flange	Rolled Steel	フランジ	SS400	2
1	Packing Seat	Stainless Steel	パッキンシート	SUS316L	2
No.	Name of Parts	Material	部品名	材質	Q.TY

Specification	
Fluid	
Max.Press.	MPa
Max.Temp.	
Expansion Amt.	+ 10, - 25 mm

SHIPPING座金、 SHIPPINGボルトは、配管(固定点及びガイド施工)後取り外しの事。

Be sure to remove the Shipping Washer and Shipping Bolt after installation(Fixing point and guide execution). (mm)

Size	L	使用最大長さ Max.operating Length	使用最小長さ Min.operating Length	最大伸縮長さ Max.Expansion Length	Do	Flange JIS 20K RF						Weight (kg)
						D	C	G	t	f	n-h	
125A	440	450	415	35	212.1	270	225	195	26	2	8-25	34.7
150A	440	450	415	35	235.1	305	260	230	28	2	12-25	43.2

TYPE EB-11 EXPANSION JOINT

伸縮管継手

Approval	M. Kume
Check	H. Tange
Drawing	T. Shinjo
Drawing No.	Y-0175-6010
Date	30 OCT.2004



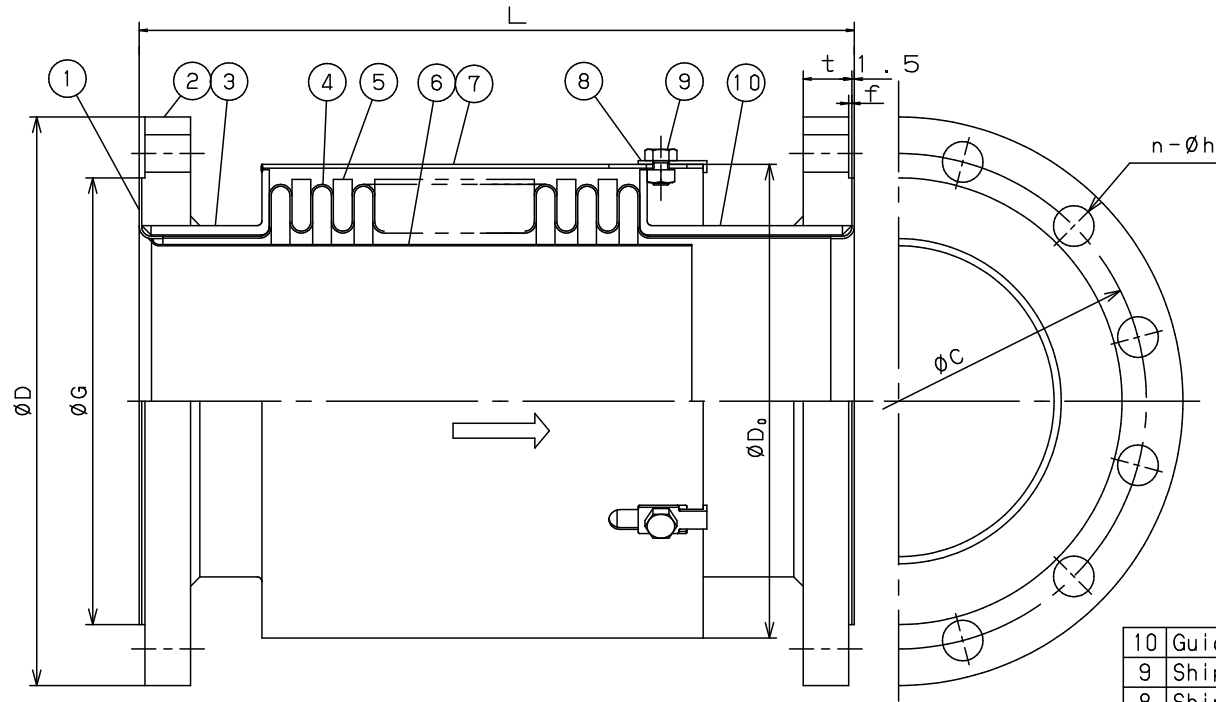

Specification	
Fluid	
Max. Press.	MPa
Max. Temp.	℃
Expansion Amt.	+10, -25 mm

10	Guide Pipe	Carbon Steel Pipe	ガイドパイプ	SGP	1
9	Shipping Bolt	Rolled Steel	SHIPPINGボルト	SS400	3set
8	Shipping Washer	Rolled Steel	SHIPPING座金	SS400	3
7	Outside Pipe	Rolled Steel	外筒	SS400	1
6	Inside Pipe	Stainless Steel	内筒	SUS316L	1
5	Control Ring	Rolled Steel	コントロールリング	SS400	1set
4	Bellows	Stainless Steel	ベローズ	SUS316L	1
3	Guide Pipe	Carbon Steel Pipe	ガイドパイプ	SGP	1
2	Flange	Rolled Steel	フランジ	SS400	2
1	Packing Seat	Stainless Steel	パッキンシート	SUS316L	2
No.	Name of Parts	Material	部品名	材質	Q. TY

※ ⑧ SHIPPING座金、⑨ SHIPPINGボルトは、配管（固定点及びガイド施工）後取り外しの事。

Be sure to remove the ⑧ Shipping Washer and ⑨ Shipping Bolt after installation (Fixing point and guide execution).

(mm)

Size	L	使用最大長さ Max. operating Length	使用最小長さ Min. operating Length	最大伸縮長さ Max. Expansion Length	Do	Flange JIS 20K RF						Weight (kg)
						D	C	G	t	f	n-h	
200A	440	450	415	35	291.6	350	305	275	30	2	12-25	55.8
250A	465	475	440	35	332.6	430	380	345	34	2	12-27	85.7

TYPE EB-11 EXPANSION JOINT  
伸縮管継手

Approval	H. Kimura
Check	M. Murata
Drawing	T. Inose
Drawing No.	Y-175-6010-3A
Date	19 JUL. 2017

**Yoshitake**  
INC.