

ICOT SMART POSITIONERS

NON-INCENDIVE INTRINSICALLY SAFE AND EXPLOSIONPROOF - NEC

Smart positioners for both spring-return and double-acting actuators on rotary and linear valves. Available with HART®, FOUNDATION Fieldbus™ and Profibus PA™ protocols



FEATURES

- 3-button interface and graphical LCD for easy calibration and information display.
- Easy configuration of split range and reverse acting operation.
- Easy access to wiring terminal connectors.
- Non-contact valve position measurement via Hall effect sensor. Eliminates the need for drive arms, linkages and increases overall resolution, accuracy and reliability.
- Advanced auto-calibration.
- Valve speed adjustable via user control.
- Available with optional dry contact limit switches.
- Optional 4-20 mA position feedback transmitter - HART® version only.
- High-flow spool valve option for larger actuator/valves. Eliminates the need for volume boosters in some applications.
- Highly visible position indicator for rotary applications.
- Easily accommodates large stroke valves, such as knife gates.
- Fully compatible with AMS™ software and DTM.
- Rugged aluminum and stainless steel enclosures for maximum protection - 6000 series.
- Engineered resin enclosure is robust yet lightweight with exceptional chemical, UV and impact resistance - 5000 series.

TECHNICAL DATA

Enclosures

5000 series	Engineered resin
6000 series	Aluminum
	Stainless steel

Communication protocol

5200	None
5300/6300	HART®
5400/6400	FOUNDATION Fieldbus™
5500/6500	Profibus PA™

GENERAL APPLICATION

By providing modulating valve position control, the ICoT range of smart digital positioners deliver reliable and effective control for both rotary and linear action valves.

ICoT SMART POSITIONERS

NON-INCENDIVE INTRINSICALLY SAFE AND EXPLOSIONPROOF - NEC

AGENCY APPROVALS

Non-incendive

Area classification (NEC 500)	
All models	Class I, Division 2, Groups A, B, C & D; Class II & III, Division 2, Groups F & G/ T4 Ta = 85°C
Enclosure standards (ANSI/NEMA 250)	
5200/5300	NEMA 4, 4X
5400/5500	NEMA 4, 4X

Intrinsically safe

Area classification (NEC 500)	
5200 and 5300	Class I, II & III, Division 1, Groups A, B, C, D, E, F & G/ T4 Ta = 85°C
5400/5500	Class I, II & III, Division 1, Groups A, B, C, D, E, F & G/ T4 Ta = 80°C
Enclosure standards (ANSI/NEMA 250)	
5200/5300	NEMA 4, 4X
5400/5500	NEMA 4, 4X

Explosionproof

Area classification (NEC 500 and 504)	
6000 series	Class I, Division 1, Groups C & D; Class II & III, Division 1, Groups E, F & G; AEx d / Ex d 1, IIB T5
Enclosure standards (ANSI/NEMA 250)	
6000 series	NEMA 4X, 6P, IP65

NON-CONTACT POSITION FEEDBACK

Unlike conventional positioners, the ICoT feeds back accurate valve position without the need for linkages, levers and rotary or linear seals. Position sensing is performed by a non-contact sensor, employing Hall effect magnetic principles. This enables the use of advanced control strategies where knowledge of valve position is used in predictive and other algorithms.

ROTARY CONTROL

There is no hysteresis within the positioner. This feature allows extremely accurate tracking of the control signal to within 0.1 mA. The non-contact position sensor is embedded within the ICoT housing. An external magnetic module, attached to the output shaft of the actuator and housed in the beacon assembly, rotates about this sensor. An analog-to-digital converter interfaces between the sensor and a microprocessor. It rotates about this sensor generating position signal which is linearized to improve accuracy and linearity of the controlled position commanded by the instrument signal.

LINEAR CONTROL

The ICoT proximity positioner provides more reliable measurement of valve stem position. A static slide-by-actuation assembly, attached to the valve stem, is the only moving part. Output updating takes place twenty times per second.

ICoT is a fully digital positioner allowing for multiple control algorithms leading to better controllability for a large range of actuators and enables a wide range of diagnostic information to be generated.

REMOTE MOUNT CAPABILITY

The ICoT has the ability to be mounted remotely (up to 50 feet) from the device it is controlling (Please consult about greater distances). This allows the positioner to be isolated if the control valve is located in either a high vibration or extremely corrosive environment.



ICoT on a typical linear diaphragm valve



Traditional ICoT Beacon

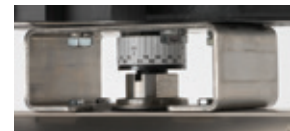

NAMUR style Beacon



Pipe mount ICoT with remote and cable set

ICoT SMART POSITIONERS

NON-INCENDIVE INTRINSICALLY SAFE AND EXPLOSIONPROOF - NEC

Negligible bleed

The ICoT 5000/6000 series positioner is designed to consume the least possible amount of control air at steady state. This means lower process air consumption and reduced demand on instrument air compressors. To increase reliability, the ICoT employs a patented lapped spool and floating sleeve design. This balanced construction relies on an air bearing which eliminates any metal-to-metal contact and results in a mean time between failures (MTBF) of 1,666,666.7 hours or 333.3 years.

Integrated position transmitter

The ICoT 5200/5300 and 6300 series are available with an integrated 4-20 mA position feedback transmitter. This cost-effective feature eliminates the need to buy externally mounted devices when knowledge of valve position is required remotely.

AutoCal intelligent calibration, local keypad

ICoT intelligent positioners are equipped with a 3-button keypad for performing on-site electronic calibration. System calibration is performed easily, requiring only minutes to accomplish. It offers the operator a choice of linear, quick-opening or equal percentage modes. Split range and reverse acting operation are also configured simply.

The AutoCal feature allows simple zero and span adjustments as well as PID and transducer calibration. The 5300/6300 and 5400/6400 series offer the option of a HART® or FOUNDATION Fieldbus™ respectively, with the 5500/6500 suitable for Profibus PA.

On-board sensors/error detection

The ICoT positioner has the capability to constantly monitor its own operation. If an error or failure condition occurs, it will be displayed on the local LCD. If the positioner is supplied with a HART® interface, the error codes will be displayed on a hand-held terminal or PC maintenance station as shown below:

Err3 = Low input pressure or clogged filter
 Err6 = Calibration error

Westlock Controls
 ICot HART Rev 1.02.00
 25.5°C
 R %PS 56.4 %SP 56.4
 12.0mA ERR3

The alarm conditions and additional diagnostic capabilities are provided through a number of sensor elements in the transducer. A pressure switch detects low air pressure entering the positioner. In conjunction with a supply pressure switch, it can be identified whether this is caused by a restricted filter or a genuine low supply pressure condition. A 0-100% position feedback transmitter is available integrated within the electronics of the ICoT 5200 and 5300/6300 series positioners.

Local LCD display

The local LCD display provides a range of on-site diagnostic information. While the valve is being controlled by the positioner and the error signal is NOT zero, the displayed information will show both setpoint and position as a percentage. The range of values displayed is from 0.0% (fully closed) to 100% (fully open). The resolution displayed is in 0.1% increments although internal calculations are maintained more precisely.

Westlock Controls
 ICot HART Rev 1.02.00
 25.5°C
 R %PS 56.4 %SP 56.4
 12.0mA ACAL

PID control

The ICoT uses proportional, integral and derivative functions, making it a true PID servo system. By combining intelligence based on present, past and the prediction of future events, the ICoT's controller is able to minimize errors and provide a precise control response.

Autotuning

Tuning, or setting of the PID functions, is carried out automatically by the microprocessor within the ICoT. This eliminates complex and time-consuming manual procedures.

5300/6300 series HART® protocol

The ICoT 5300/6300 series positioner responds to HART® commands for ease of calibration and provides intelligence for the control valve through a microprocessor-based diagnostic system utilizing the HART® protocol.

5400/6400 series FOUNDATION Fieldbus™ protocol

The ICoT 5400/6400 series features the FOUNDATION Fieldbus™ communication protocol, is an industry proven international standard (IEC 61158) designed for use in the process industry. Its features include multi-drop capabilities (as many as 32 devices per segment), extended trunk length, and single loop integrity. It also offers control in the field, power and communications on a shielded twisted pair network and compatibility with intrinsically safe networks.

A key feature of the FF protocol is the ability to select where control of the process is situated – in the host, in the field or in various combinations of both locations.

5500/6500 series Profibus PA™ protocol

The ICoT 5500/6500 series features the Profibus PA™ communication protocol. Similarly to the Foundation Fieldbus devices, Profibus PA™ (Process Automation) physical layer conforms to the IEC61158-2 international industry proven standard allowing for multi-drop communication to 32 devices per segment and extended trunk length. ICoT 5500/6500 is an intrinsically safe positioner utilizing single, twisted pair shielded cable for power and communication. Functional advantages include transmission reliability, self-test functions, diagnostic, distributed intelligence, local and remote auto-calibration. To simplify integration of ICoT 5500/6500 positioners Westlock provides GSD (General Station Description) containing key device data as well as EDD (Electronic Device Description) and DTM (Device Type Manager).

ICoT SMART POSITIONERS

NON-INCENDIVE INTRINSICALLY SAFE AND EXPLOSIONPROOF - NEC

ICoT 5300/6300, 5400/6400 AND 5500/6500 SERIES INTELLIGENT POSITIONERS WITH HART®, FOUNDATION FIELDBUS™ AND PROFIBUS PA NETWORK CAPABILITIES

Proven, Interoperable solutions even in the Harshest Environments

The ICoT positioner series has been successfully used for more than 15 years in many challenging and diverse applications in industries such as, Oil and Gas, Chemical, Power, Pulp and Paper and Sugar and Ethanol. Although it has a proven track record, Westlock is constantly improving the ICoT line of positioners. Recent developments have enhanced the ICoT electronics robustness and performance even when submitted to vibration and EMI. In the mechanical arena, an explosion proof solution and stainless steel housing option is now available. Software upgrades ensure the ICoT series is up to date with the most recently released industry standards, like the FF's ITK 6.0.1 (one of the first in the market) and the new 5500/6500 series is now compatible with the Profibus PA protocol.

Our goal is to provide the ICoT user with a truly open, independent and interoperable solution able to interface with different host system brands and vendors.

In order to support the integration of ICoT positioners in to the user's host system of choice, you can download all the necessary HART®, Fieldbus Foundation or Profibus files from our website. Please visit www.westlockcontrols.com to find:

- ICoT 5300/6300 (HART):
 - EDD (also available at <http://www.hartcomm.org> in the Product Catalog - Wired Products menu)
 - DTM (available also at <http://www.fdtgroup.org> in the Product Catalog - Certified DTM's catalog)
- ICoT 5400/6400 (Foundation Fieldbus)
 - EDD (available at www.fieldbus.org in the End User Resources - Registered Products)
- ICoT 5500/6500 (Profibus PA)
 - EDD (available at <http://www.hartcomm.org> in the Product Catalog - Wired Products menu or at <http://www.fdtgroup.org> in the Product Catalog - Certified DTM's catalog)

Additional features and benefits

The ICoT 5300/6300, 5400/6400 and 5500/6500 series provide intelligence to the control valve through microprocessor-based systems using the HART®, FOUNDATION Fieldbus™ and Profibus PA protocols respectively. These offer additional benefits in intelligent calibration, control and on-line diagnostics.

Intelligent calibration

Accurate measurement of valve stem position, input signal, actuator pressure, cycle time and cycle count data are recorded during normal operation, providing information for control valve signature generation. The positioner has a local LCD display which indicates valve position, set-point in percentage open, calibration status, alarms status and, for the 5400/6400 (FF) and 5500/6500 (PA), whether the ICoT is in local or fieldbus control.

Intelligent control

Control valves are the most maintenance-intensive components commonly used in instrumentation and control systems. Internal parameter sensing within the valve positioner gives early warning of the need for maintenance.

On-line diagnostics

The ICoT possesses the capability to predict rather than react to valve maintenance needs. Operating personnel gain a real time perspective on the state of control at the valve, including a view of operating integrity and emerging alert conditions. Timely information about each control valve's condition is quickly made available to the plant's production and maintenance engineers.

The principal advantage of online diagnostics is the ability to detect deviations from established patterns of behavior as they occur under actual operating conditions.

The ICoT positioner's diagnostic capability observes the following parameters:

- Valve position vs. input signal.
- Actuator pressure vs. valve position.
- Airset filter outlet pressure.
- Confirmation of principal operating pressures within the positioner.
- Pressure generation within packing gland area.
- These enable the following to be diagnosed:
 - 'Stick-slip' detection.
 - Excessive static position error.
 - Low air supply pressure.
 - Clogged air supply filter.
 - Restricted transducer nozzle.
 - Transducer diaphragm air leak.
 - Non-functioning spool valve.
 - Calibration error

ICoT SMART POSITIONERS

NON-INCENDIVE INTRINSICALLY SAFE AND EXPLOSIONPROOF - NEC

HAND-HELD TERMINALS

Model 5300/6300

A single 4-20 mA ICoT positioner with up to two master devices may be connected to each HART® loop. The primary master is generally a management system or a PC while the secondary unit can be a handheld terminal or laptop computer.

A standard hand-held HART® Communicator is available for making field operations as uniform as possible. Communication is accomplished by superimposing a high frequency signal on top of the 4-20 mA output signal. This allows simultaneous communication and output without comprising loop integrity.

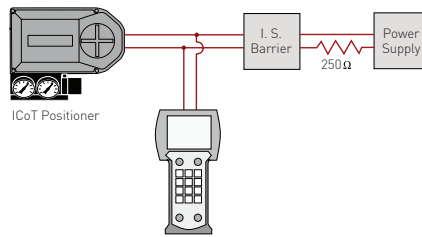

Model 5400/6400

Foundation Fieldbus compatible hand held terminals (like the Rosemount Field Communicator) can communicate with the ICoT 5400/6400 series smart positioners via the FF protocol.

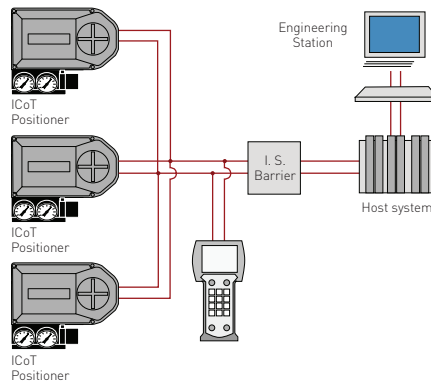

Model 5500/6500

Similar to the Fieldbus Foundation, a Profibus PA tester, like the MTL FBT6-PA, can be used in hazardous areas. Several testers and bus analyzers are also available to be used directly from the DP network in the safe area.

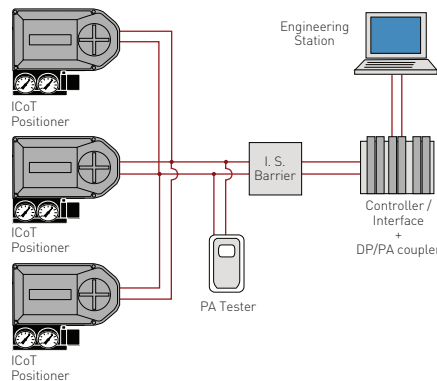

ICOT 5000 SERIES POSITIONERS

NON-INCENDIVE AND INTRINSICALLY SAFE - NEC

TECHNICAL SPECIFICATIONS

Electrical	5200/5300	5400	5500
Input signal	4-20 mA	Two wire FOUNDATION Fieldbus™	Two wire Profibus PA™
Minimum voltage	9.0 V DC	9.0 V DC	9.0 V DC
Maximum voltage	30.0 V DC	32.0 V DC	32.0 V DC
Impedence	450 ohms at 20 mA	N/A	N/A
Reverse polarity protection	Yes	Polarity insensitive	Polarity insensitive
Pneumatic	5200/5300/5400/5500		
Supply pressure*	15 to 45 psi (low pressure option) 40 to 120 psi (high pressure option)		
Output flow rate	8.0 scfm @ 25 psi 16.2 scfm @ 90 psi		
Air consumption	0.03 scfm @ 20 psi (low) 0.08 scfm @ 90 psi (high)		
High flow option	40 scfm @ 90 psig supply 10% to 90% non-condensing		
Technical	5200/5300/5400/5500		
Linearity	± 0.5% Rotary ± 1.0% Linear (for travel under 1.25")		
Valve travel	Rotary: Minimum 45°, Maximum 95° Linear: Minimum 0.25", Maximum 48"		
Hysteresis	0.2% of span		
Repeatability	0.2% of span		
Environmental	5200/5300/5400/5500		
Operating temperature	-40°F to +185°F [-40°C to +85°C]		
Thermal coefficient	3% / 100°C		
Mechanical	5200/5300/5400/5500		
Connections	Pneumatic: ¼" NPT (F) (¾" NPT (F) for High Flow version) (BSP optional) Electrical: ½" NPT (F) (M20 optional)		
Materials of construction	Enclosure: Nylon, glass filled Cover gasket: Silicone Pneumatic manifold: Aluminum anodized die cast zinc Pneumatic seals: NBR		
Weight	7.2 pounds (3.27 Kg)		
Optional features	5200/5300/5400/5500		
Airset	Filter regulator combo with 5 micron filter element		
Limit switches	Two SPST hermetically sealed switches (rated for 2 A at 24 V DC)		
Feedback transmitter	4-20 mA output (loop powered)		

* As required by actuator for proper control



ICOT 5000 SERIES POSITIONERS

NON-INCENDIVE AND INTRINSICALLY SAFE - NEC

DIMENSIONS – ROTARY CONTROL

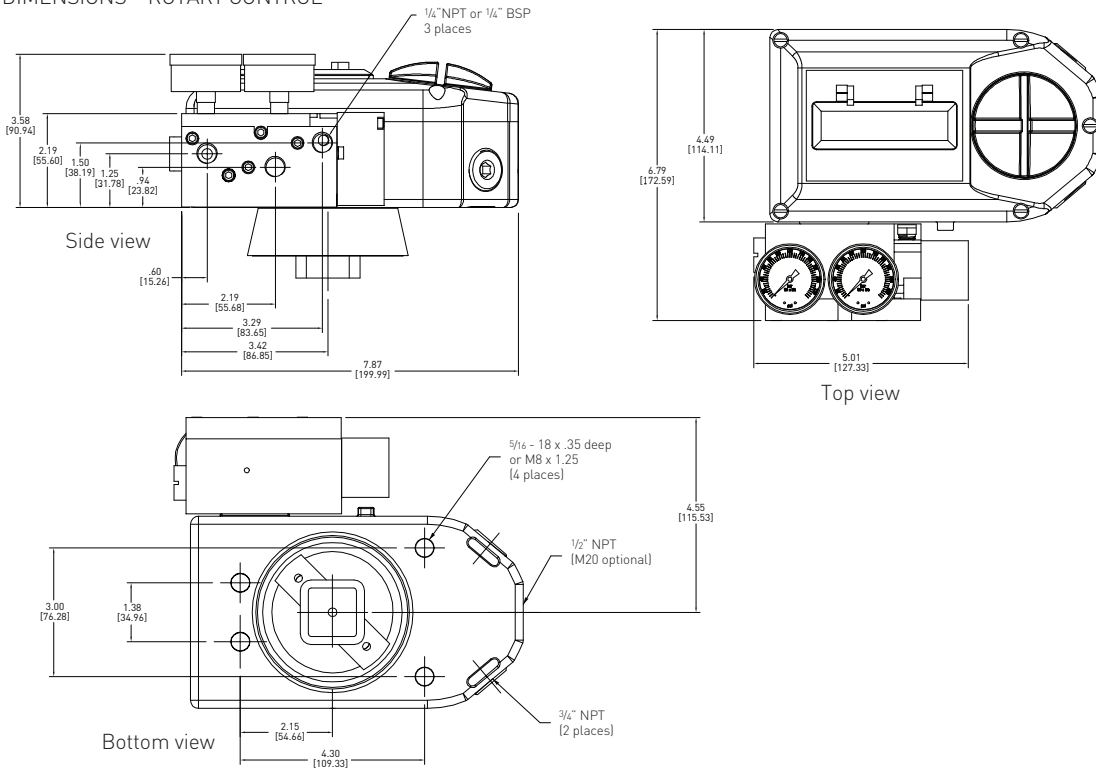

Dimensions in inches, metric dimension (mm) in parentheses

Note: Product shown is standard flow variant

DIMENSIONS – ROTARY CONTROL WITH SWITCHES

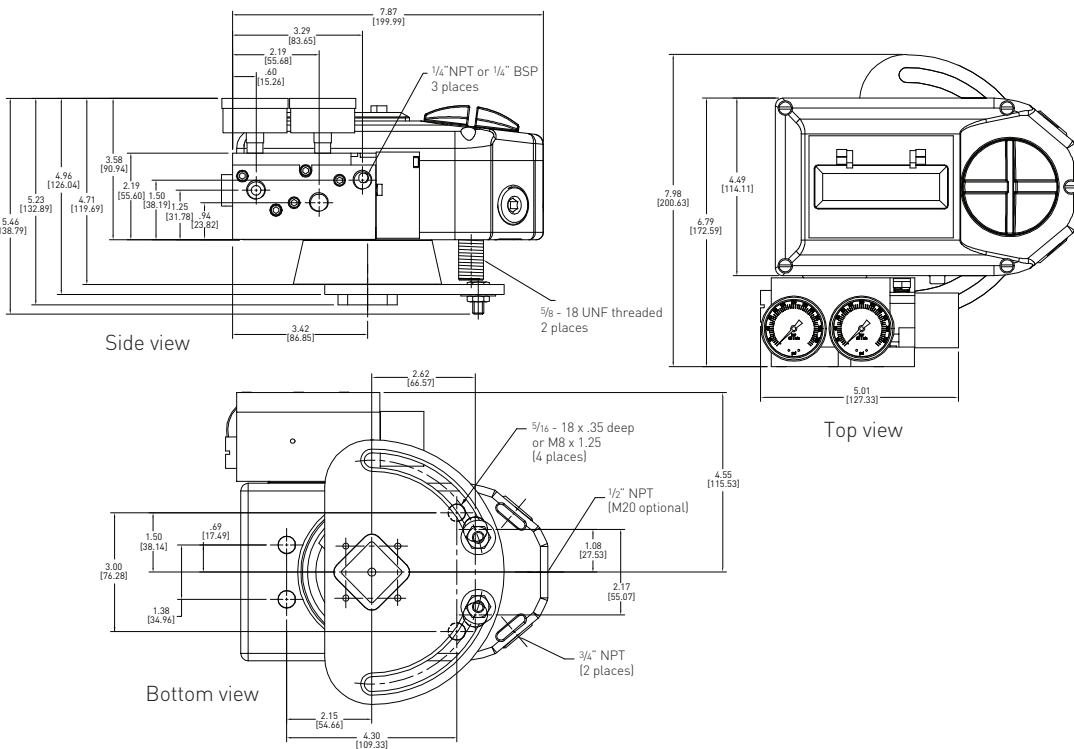

Dimensions in inches, metric dimension (mm) in parentheses

Note: Product shown is standard flow variant

ICOT 5000 SERIES POSITIONERS

NON-INCENDIVE AND INTRINSICALLY SAFE - NEC

DIMENSIONS – LINEAR CONTROL

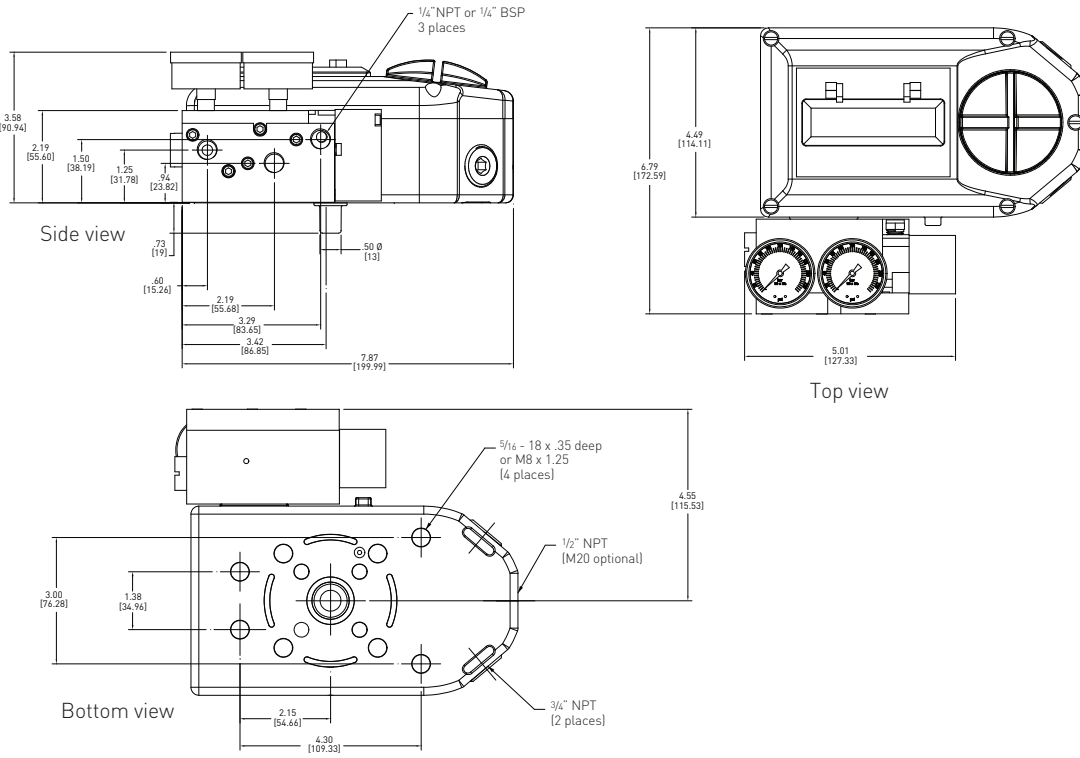

Dimensions in inches, metric dimension (mm) in parentheses

Note: Product shown is standard flow variant

ICoT 5000 SERIES POSITIONERS

SELECTION GUIDE

Base model

- 52 Intelligent positioner
- 53 Intelligent positioner with HART® capability
- 54 FOUNDATION Fieldbus™ positioner
- 55 Profibus PA™ positioner

Actuator type

- 1 Linear (Free magnet assembly include up to 2½" stroke; for strokes > 2½", contact your sales representative)
- 3 Rotary

Mounting style

- 0 Direct mount (ICoT mounted on actuator)
- 5 Remote mount (ICoT mounted remote from actuator)
- 7 NAMUR mount (order with stainless NAMUR mounting kit separately)
- 8 ModMount (for Keystone MRP and 79U actuators only; supplied with mounting kit)

Hazardous rating

- NI Non-incendive - NEC 500
- IS Intrinsically Safe - NEC 500

Housing material

- E Engineered resin

Supply pressure

- H High pressure (40 - 120 psi)
- L Low pressure (15 - 45 psi)
- V High flow (40 - 120 psi for larger actuators)
- S Super high flow (40 - 120 psi, 5.5 C_v)

Calibration/communication

- K Via 3-Button on-board keypad (Series 52 only)
- B 3-Button on-board keypad and Hart protocol (Series 53 only)
- F 3-Button on-board keypad and Fieldbus protocol (Series 54 only)

Conduit entry

- A One ½" NPT (F)
- B One M20 (F)

Limit switch options

- 0 None
- 2 Two SPST hermetically sealed (Mounting style 0 only)

Position transmitter output

- A None
- B 4-20 mA transmitter (Series 52 and 53 only)

Pneumatic connections

- N ¼" NPT (¾" NPT with high flow option)
- B ¼" BSP (¾" BSP with high flow option)
- F ¼" NPT with filter-regulator assembly (¾" NPT with high flow option)

53 3 5 IS E H B A 0 B N = Model number **5335ISEHBA0BN**

NOTES

1. Please contact your sales office for guidance on selecting the best possible combination for your control and monitoring requirements.
2. See Hazardous area classification technical bulletin for further information on global standards.