

**Voegt**

**Forged Steel  
Valves**





## ***Vogt Valves***

### ***A History in the Making***

In the late 1890s, Vogt pioneered the early development of ammonia absorption refrigeration systems that made artificial ice. This business, plus Vogt's fledgling boiler business, created an internal need for quality valves that initiated Vogt's early entry into the valve manufacturing business.

The early reputation of Vogt's quality valves and rapidly growing petroleum processing industry created an outside demand that would firmly establish Vogt in the mass production of high-quality forged steel valves.

For more than 100 years, Vogt's leadership has been evident in the production of forged steel gate, globe, angle and check valves in most popular materials, trims and bonnet configurations.

Today, Vogt valves support a worldwide network of distributors with access to the world's largest capability for manufacturing of forged steel valves.

GLOBE VALVE INDEX													Page	
Press. Class	Material	Bonnet Joint	Gasket	SEAT	Configuration	Bonnet Type	Wall Thick.	Ports				SERIES		
								Threaded	Socket Weld	Butt Weld	Flanged			
150	A105	Bolted	Bellows Seal	Integral		OS&Y		Conv				473B	63	
	A182 F316/F316 L					OS&Y		Conv				478B	63	
	A105	Bolted	Spiral Wound	Integral		OS&Y		Conv	See Class 800	See Class 800		473	40	
	A182 F316/F316 L					OS&Y		Conv				478	40	
300	A350 LF2					OS&Y		Conv				32473	40	
	A105	Bolted	Bellows Seal	Integral		OS&Y		Conv				483B	63	
	A182 F316/F316 L					OS&Y		Conv				488B	63	
	A105	Bolted	Spiral Wound	Integral		OS&Y		Conv	See Class 800	See Class 800	BW483	483	41	
	A182 F316/F316 L					OS&Y		Conv			BW488	488	41	
	A350 LF2					OS&Y		Conv			BW32483	32483	41	
600	A105	Bolted	Spiral Wound	Removable		OS&Y		Conv			BW22483	22483	71	
	A350 LF2					OS&Y		Conv				36483	71	
	A105	Bolted	Bellows Seal	Integral		OS&Y		Conv				493B	63	
	A182 F316/F316 L					OS&Y		Conv				498B	63	
	A105	Bolted	Spiral Wound	Integral		OS&Y		Conv	See Class 800	See Class 800	BW493	493	42	
	A182 F316/F316 L					OS&Y		Conv			BW498	498	42	
	A350 LF2					OS&Y		Conv			BW32793	32493	42	
	A105	Bolted	Spiral Wound	Removable		OS&Y		Conv				22493	71	
	A350 LF2					OS&Y		Conv				36493	71	
	A105					OS&Y		Full	43241				69	
800	A105	Bolted	Bellows Seal	Integral		OS&Y		API 600	Full			10403	58	
	A182 F316/F316 L					OS&Y		Conv	12141B	SW12141B			63	
	A105	Bolted	Spiral Wound	Integral		OS&Y		Conv	12501B	SW12501B			63	
						OS&Y		Conv	12141	SW12141	BW12141		38	
					Angle		OS&Y		Full	13141	SW13141		38	
							OS&Y		Conv	1971	SW1971		44	
					Throttling		OS&Y		Conv	12443	SW12443		66	
					Needle Pt.		OS&Y			22461	SW22461		64	
					Removable		OS&Y			22141	SW22141		72	
							OS&Y		Full	23141	SW23141		69	
					Integral		ISS		API 600	Full	10103	SW10103		59
					Integral		OS&Y		Conv	12181	SW12181		46	
					Integral	Extended Male Thread end	OS&Y		Conv	TT12141			57	
					Integral	Extended Male Socket Weld end	OS&Y			ST12141	SS12141		57	
					Integral	Extended Male Couplet end	OS&Y			CT12141	CS12141		57	
			Weld		Integral		OS&Y		Conv	2821	SW2821		49	
			Union	Spiral Wound	Integral	Y pattern	OS&Y		Full	810	SW810		51	
							OS&Y		Conv	801	SW801		47	
							ISS			851	SW851		46	
		A350 LF2	Bolted	Spiral Wound	Integral		OS&Y		Conv	32141	SW32141		38	
							OS&Y		Full	33141	SW33141		38	
			Weld		Integral		OS&Y		Conv	32821	SW32821		50	
		A182 F316/F316 L	Bolted	Spiral Wound	Integral		OS&Y		Conv	12501	SW12501		38	
							OS&Y		Full	13501	SW13501		38	
			Weld		Integral		OS&Y		Conv	2841	SW2841		49	
		A182 F316H	Bolted	Spiral Wound	Integral		OS&Y		Conv	82501	SW82501		38	
		A182 F5					OS&Y			12251	SW12251			
		A182 F11, CL2	Weld		Integral		OS&Y		Full	811	SW811		51	
		A182 F22 CL 3	Bolted	Spiral Wound	Integral		OS&Y		Conv	12351	SW12351		38	
							OS&Y			12551	SW12551		38	
			Weld		Integral		OS&Y		Full	822	SW822		51	
	1500	A105	Bolted	Spiral Wound	Integral		OS&Y		Conv	15141	SW15141	BW15141		45
						OS&Y		Full	16141	SW16141				
					Throttling		OS&Y		Conv	15443	SW15443		15493VP	
					Ring Joint	Removable	OS&Y	API 600	Full	1003	SW1003		10683	
					Spiral Wound		OS&Y		Full	1023	SW1023		10603	
					Integral	Flanged	OS&Y		Conv			BW15493	15493	
			Weld		Integral		OS&Y		Conv	15821	SW15821		50	
		A350 LF2					OS&Y			35821	SW35821		50	
			Bolted	Spiral Wound	Integral		OS&Y		Conv	35141	SW35141		45	
		A182 F316/F316 L					OS&Y			15501	SW15501		45	
			Weld		Integral		OS&Y		Conv	15841	SW15841		50	
		A182 F11, CL2	Bolted	Spiral Wound	Integral		OS&Y		Conv	15351	SW15351		45	
		A182 F22 CL 3					OS&Y			15551	SW15551		45	
1500LTD		A105	Weld		Integral		OS&Y		Conv		SW65723		50	
1690	A105	Weld		Integral	Y pattern	OS&Y		Conv	1510	SW1510		52		
		Screw	Sp. Wound			OS&Y			R1510	SWR1510		53		
	A350 LF2	Weld		Integral	Y pattern	OS&Y		Conv	31510	SW31510		52		
	A182 F11, CL2	Weld		Integral	Y pattern	OS&Y		Conv	1511	SW1511		52		
		Screw	Sp. Wound				OS&Y		R1511	SWR1511		53		
	A182 F22 CL 3	Weld		Integral	Y pattern	OS&Y		Conv	1522	SW1522		52		
2500* 2680*		Screw	Sp. Wound			OS&Y			R1522	SWR1522		53		
	A105	Weld		Integral		OS&Y		Full	66723	SW66723		50		
						OS&Y			2510	SW2510		55		
		Screw	Sp. Wound		Y pattern		OS&Y		R2510	SWR2510		56		
	A350 LF2	Weld		Integral		OS&Y		Full	66753	SW66753		54		
						OS&Y			32510	SW32510		55		
	A182 F11, CL2	Weld		Integral		OS&Y		Full	66733	SW66733		54		
						OS&Y			2511	SW2511		55		
		Screw	Sp. Wound		Y pattern		OS&Y		R2511	SWR2511		56		
	A182 F22 CL 3	Weld		Integral		OS&Y		Full	66793	SW66793		54		
						OS&Y			2522	SW2522		55		
		Screw	Sp. Wound		Y pattern		OS&Y		R2522	SWR2522		56		
	A182 F91	Weld		Integral		OS&Y		Full	66783	SW66783		54		

\* Threaded series rated at 2500 LTD and Socket Weld series rated at 2680 LTD

## ***Globe Valve***

Globe and angle valves are suitable for throttling as well as shut-off. They are customarily installed so that the media pressure and preferred flow direction are under the disc (as illustrated). Flow above the disc is also acceptable.

The Vogt globe and angle valve lines provide a variety of design variations to fulfill your requirements. Flow characteristics can be determined from the Cv Factors listed.

Dimensions in the catalog selection pages are in inches and millimeters.

Dimensions are subject to change without notice.

See pages 38 – 80 for globe valve selections.

Drawings for currently available globe valve configurations are available at:  
[http://Vogt Valves.vogtvalves.com/search\\_drawings.asp](http://Vogt%20Valves.vogtvalves.com/search_drawings.asp)



# Forged Globe Valves – Bellowseal

## Class 150, 300, 600, 800 Globe Valve

1 Conventional Port

2 Full Port

Round Bolted Bonnet

Spiral Wound Gasket

Outside Screw &amp; Yoke

Bolted Gland

Multi-Ply Bellows: 316L

Disc: Hard Faced 316

Seat: Integral Hard Faced

ASME B16.34

API 602

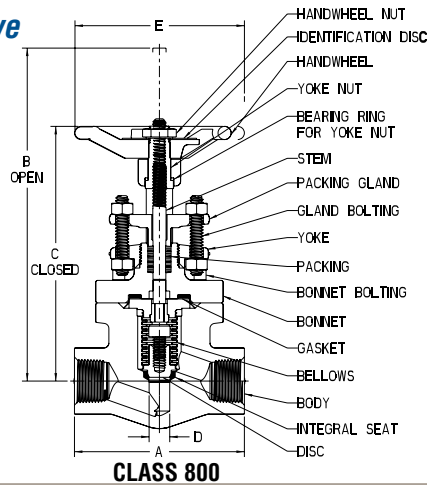
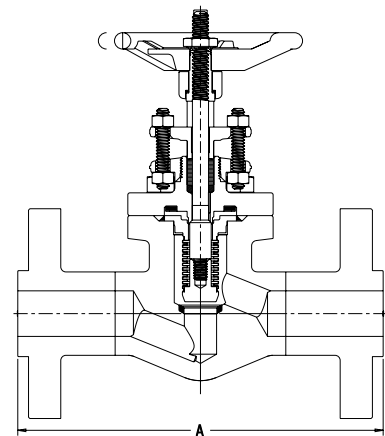
**CLASS 800**

**CLASS 150, 300, 600**

Bellowseal globe valves are suitable for applications requiring total containment of the flowing media frequently necessary to protect the environment and to eliminate the loss of hazardous and/or costly fluids. The valve packing and bonnet gasket are totally isolated by the bellows from the flowing media and pressure. The packing and gasket are incorporated in the valve to serve in a “backup” role only.

CONNECTION	CONV PORT	FULL PORT	BODY/BONNET	STEM	SEAT	RATING		CLASS
1/16 RF	473B	13473B	A105	13% Cr	HF	285 PSI @ 100 F	19.6 BAR @ 38 C	150
	478B	13478B	A182 F316			275 PSI @ 100 F	19.0 BAR @ 38 C	
1/16 RF	483B	13483B	A105	13% Cr	HF	740 PSI @ 100 F	51.1 BAR @ 38 C	300
	478B	13488B	A182 F316			720 PSI @ 100 F	49.6 BAR @ 38 C	
1/4 RF	493B	13493B	A105	13% Cr	HF	1480 PSI @ 100 F	102.1 BAR @ 38 C	600
	498B	13498B	A182 F316			1440 PSI @ 100 F	99.3 BAR @ 38 C	
Threaded Socket Weld Butt Weld	12141B	13141B	A105	13% Cr	HF	1975 PSI @ 100 F	136.2 BAR @ 38 C	800
	12501B	13501B	A182 F316			1920 PSI @ 100 F	132.4 BAR @ 38 C	

### Dimensions

SIZE	A				B	C	D	E	Weight				Cv	T	P			
	150	300	600	800					150	300	600	800						
CONVENTIONAL PORT	-04	NPS	½	4.25	6.00	6.50	3.75	6.32	6.13	.50	4.00	7.0	8.7	8.8	5.2	2.2	2.3	12
		DN	15	108	152	165	95	161	156	12.7	102	3.2	3.9	4.0	2.4			
	-05	NPS	¾	4.62	7.00	7.50	4.00	6.32	6.13	.50	4.00	8.4	11.5	12.0	5.6	3.9	2.3	12
		DN	20	117	178	191	102	161	156	12.7	102	3.8	5.2	5.4	2.5			
	-06	NPS	1	5.00	8.00	8.50	4.62	7.03	6.75	.75	4.75	12.5	15.5	17.7	8.5	5.2	2.6	10
		DN	25	127	203	216	117	179	171	19.1	121	5.7	7.0	8.0	3.9			
-09	NPS	2	8.00	10.50	11.50	7.75	10.04	9.52	1.53	8.00	38.2	43.8	49.3	29.0	20.5	4.0	8	
	DN	50	203	267	292	197	255	242	38.9	203	17.3	19.9	22.4	13.2				
FULL PORT	-05	NPS	¾		7.00	7.50	4.00	7.03	6.75	0.75	4.75		15.1	14.5	8.7	5.7	3.1	12
		DN	20		178	191	102	179	171	19.1	121		6.8	6.6	3.9			
	-08	NPS	1½		9.00	9.50	7.75	10.04	9.52	1.53	7.00		43.8	49.3	29.0	21.2	6.1	10
		DN	40		229	241	197	255	242	38.9	178		19.9	22.4	13.2			

T – Approximate number of turns from open to close.

P – Pitch of stem thread.

Refer to page 4 for optional trim and service configurations.

Refer to pages 126 &amp; 127 for full materials description.

Refer to page 111-113 for end connections.

Refer to pages 114-115 for other ratings

## Recommended Valve Orientation

VALVE TYPE	STEM ORIENTATION HORIZONTAL LINE <sup>(1)</sup>	STEM ORIENTATION VERTICAL LINE <sup>(2)</sup>
Gate	Any (except vertical down) Preferred vertical stem upright	Any Preferred stem horizontal
Gate Valve <sup>(3)</sup> Motor/air-operated	Any (except vertical down) Preferred vertical stem upright	Any Preferred stem horizontal
Globe-T pattern	Any (except vertical down) Preferred vertical stem upright	Any Preferred stem horizontal
Globe-T pattern <sup>(3)</sup> Motor/air-operated	Any (except vertical down) Preferred vertical stem upright	Any Preferred stem horizontal
Globe-Y pattern	Any Preferred stem at $\pm 50^\circ$ to pipe run in upright position.	Any Preferred stem at $\pm 50^\circ$ to normal of pipe run
Globe-Y pattern <sup>(3)</sup> Motor/air-operated	Any Preferred stem at $\pm 50^\circ$ to pipe run in upright position.	Any Preferred stem at $\pm 50^\circ$ to normal of pipe run
Angle	Any (except vertical down) Preferred vertical stem upright	Any Preferred stem vertical upright
Angle <sup>(3)</sup> Motor/air-operated	Any (except vertical down) Preferred vertical stem upright	Any Preferred stem vertical upright
Ball or Piston lift check valve-T pattern (no spring) (includes stop check valve)	Preferred vertical Upright Rotation off top dead center $\pm 40^\circ$	Not recommended
Ball or Piston lift check valve-T pattern (spring-controlled)	Preferred vertical upright Rotation off top dead center $\pm 90^\circ$	Any
Piston lift check valve-Y pattern (spring-controlled)	Preferred vertical upright Rotation off top dead center $\pm 90^\circ$	Any
Swing check valve	Preferred vertical upright Rotation off top dead center $\pm 30^\circ$	Any, but upward vertical flow required
Stop check valves	Preferred vertical Upright Rotation off top dead center $\pm 40^\circ$	Not recommended

### General

- Gate, globe, angle and spring-controlled check valve designs oriented with stems or body run vertical down orient the valve body cavities in such a manner that debris can be collected and not get flushed out. This may cause unreliable valve operation. A vertical stem down or body run down orientation is not recommended for fluid service that may include debris.
- Recommended orientation of motor/air-operated valves may be changed by the recommended orientation of the actuator.

### Notes

- <sup>(1)</sup> A  $\pm 5^\circ$  variation off horizontal for the pipe would not change the recommended except for swing check valves. This valve design will not close by gravity if the piping is off horizontal, which allows the swing check mechanism to swing away from the seat.
- <sup>(2)</sup> A  $\pm 5^\circ$  off variation vertical for vertical piping does not change the recommendations in the table.
- <sup>(3)</sup> For small-bore socket welding and threaded valves equipped with a motor or air operator mounted in a horizontal plane, it is recommended that external supports to be added to the piping arrangement to remove the load from the connecting socket welds or threads of the valve.

# End Connections

## Raised Face & Ring Joint Flange

Valve flanges conform to ASME Standard B16.5 and end-to-end dimensions conform to ASME B16.10

- A0 - Raised Face - Gate, Globe, Check
- A1 - Raised Face - Gate
- A2 - Raised Face - Globe, Check
- A3 - Ring Joint - Gate, Globe
- A4 - Raised Face - Swing Check

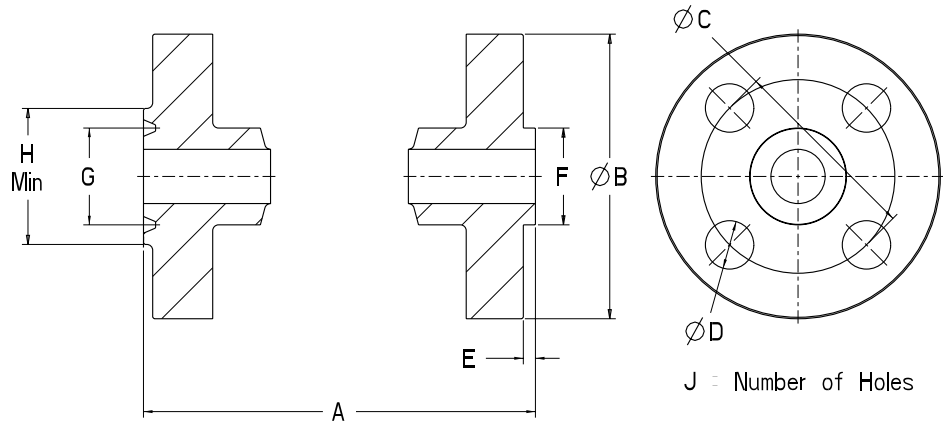

### Dimensions

			CLASS 150									
SIZE			A1	A2	B	C	D	E	F	G	H	J
-04	NPS	½	4.25	4.25	3.50	2.38	0.62	0.06	1.38			4
	DN	15	108.0	108.0	88.9	60.45	15.8	1.52	35.1			4
-05	NPS	¾	4.62	4.62	3.88	2.75	0.62	0.06	1.69			4
	DN	20	117.4	117.4	98.6	69.85	15.8	0.06	42.9			4
-06	NPS	1	5.00	5.00	4.25	3.12	0.62	0.06	2.00	1.875	2.50	4
	DN	25	127.0	127.0	108.0	79.25	15.8	1.52	50.8	47.63	63.5	4
-07	NPS	1¼	5.50	5.50	4.62	3.50	0.62	0.06	2.50	2.250	2.88	4
	DN	32	139.7	139.7	117.4	88.90	15.8	1.52	63.5	57.15	73.2	4
-08	NPS	1½	6.50	6.50	5.00	3.88	0.62	0.06	2.88	2.562	3.25	4
	DN	40	165.1	165.1	127.0	98.55	15.8	1.52	73.2	65.07	82.6	4
-09	NPS	2	7.00	8.00	6.00	4.75	0.75	0.06	3.62	3.250	4.00	4
	DN	50	177.8	203.2	152.4	120.65	19.1	1.52	92.0	82.55	101.6	4
-10	NPS	2½	7.50	8.50	7.00	5.50	0.75	0.06	4.12	4.000	4.75	4
	DN	65	190.5	215.9	177.8	139.70	19.1	1.52	104.7	101.60	120.7	4
-11	NPS	3	8.00	9.50	7.50	6.00	0.75	0.06	5.00	4.500	5.25	4
	DN	80	203.2	241.3	190.5	152.40	19.1	1.52	127.0	114.30	133.4	4

-13	NPS	4	9.00	11.50	9.00	7.50	0.75	0.06	6.19	5.875	6.75	
	DN	100	228.6	292.1	228.6	190.50	19.1	1.52	157.2	149.23	171.5	8

CLASS 300											
A1	A2	A4	B	C	D	E	F	G	H	J	
5.50	6.00	6.00	3.75	2.62	0.62	0.06	1.38	1.344	2.00		4
139.7	152.4	152.4	95.3	66.55	15.8	1.52	35.1	34.14	50.8		4
6.00	7.00	7.00	4.62	3.25	0.75	0.06	1.69	1.688	2.50		4
152.4	177.8	177.8	117.4	82.55	19.1	0.06	42.9	42.88	63.5		4
6.50	8.00	8.50	4.88	3.50	0.75	0.06	2.00	2.00	2.75		4
165.1	203.2	215.9	124.0	88.90	19.1	1.52	50.8	50.80	69.9		4
7.00	8.50	9.00	5.25	3.88	0.75	0.06	2.50	2.375	3.12		4
177.8	215.9	228.6	133.4	98.55	19.1	1.52	63.5	60.33	79.3		4
7.50	9.00	9.50	6.12	4.50	0.88	0.06	2.88	2.688	3.56		4
190.5	228.6	241.3	155.5	114.30	22.4	1.52	73.2	68.28	90.4		4
8.50	10.50	10.50	6.50	5.00	0.75	0.06	3.62	3.250	4.25		8
215.9	266.7	266.7	165.1	127.00	19.1	1.52	92.0	82.55	108.0		8
9.50	11.50	11.50	7.50	5.88	0.88	0.06	4.12	4.000	5.00		8
241.3	292.1	292.1	190.5	149.35	22.4	1.52	104.7	101.60	127.0		8
11.12	12.50	12.50	8.25	6.62	0.88	0.06	5.00	4.875	5.75		8
282.5	317.5	317.5	209.6	168.15	22.4	1.52	127.0	123.83	146.1		8
12.00	14.00	14.00	10.00	7.88	0.88	0.06	6.19	5.875	6.88		8
304.8	355.6	355.6	254.0	200.15	22.4	1.52	157.2	149.23	174.8		8

### Dimensions

			CLASS 600									
SIZE			A1	A2	B	C	D	E	F	G	H	J
-04	NPS	½	6.50	6.50	3.75	2.62	0.62	0.25	1.38	1.344	2.00	4
	DN	15	165.1	165.1	95.3	66.55	15.8	6.35	35.1	34.14	50.8	4
-05	NPS	¾	7.50	7.50	4.62	3.25	0.75	0.25	1.69	1.688	2.50	4
	DN	20	190.5	190.5	117.4	82.55	19.1	0.06	42.9	42.88	63.5	4
-06	NPS	1	8.50	8.50	4.88	3.50	0.75	0.25	2.00	2.00	2.75	4
	DN	25	215.9	215.9	124.0	88.90	19.1	6.35	50.8	50.80	69.9	4
-07	NPS	1¼	9.00	9.00	5.25	3.88	0.75	0.25	2.50	2.375	3.12	4
	DN	32	228.6	228.6	133.4	98.55	19.1	6.35	63.5	60.33	79.3	4
-08	NPS	1½	9.50	9.50	6.12	4.50	0.88	0.25	2.88	2.688	3.56	4
	DN	40	241.3	241.3	155.5	114.30	22.4	6.35	73.2	68.28	90.4	4
-09	NPS	2	11.50	11.62	6.50	5.00	0.75	0.25	3.62	3.250	4.25	8
	DN	50	292.1	295.2	165.1	127.00	19.1	6.35	92.0	82.55	108.0	8
-10	NPS	2½	13.00	13.12	7.50	5.88	0.88	0.25	4.12	4.000	5.00	8
	DN	65	330.2	333.3	190.5	149.35	22.4	6.35	104.7	101.60	127.0	8
-11	NPS	3	14.00	14.12	8.25	6.62	0.88	0.25	5.00	4.875	5.75	8
	DN	80	355.6	358.7	209.6	168.15	22.4	6.35	127.0	123.83	146.1	8
-13	NPS	4	17.00	17.12	10.75	8.50	1.00	0.25	6.19	5.875	6.88	8
	DN	100	431.8	434.9	273.1	215.90	25.4	6.35	157.2	149.23	174.8	8

CLASS 1500											
A0	A3	B	C	D	E	F	G	H	J		
8.50	8.50	4.75	3.25	0.88	0.25	1.38	1.562	2.38			4
215.9	215.9	120.7	82.55	22.4	6.35	35.1	39.67	60.5			4
9.00	9.00	5.12	3.50	0.88	0.25	1.69	1.750	2.62			4
228.6	228.6	130.1	88.90	22.4	0.06	42.9	44.45	66.6			4
10.00	10.00	5.88	4.00	1.00	0.25	2.00	2.000	2.81			4
254.0	254.0	149.4	101.60	25.4	6.35	50.8	50.80	71.4			4
11.00	11.00	6.25	4.38	1.00	0.25	2.50	2.375	3.19			4
279.4	279.4	158.8	111.25	25.4	6.35	63.5	60.33	81.0			4
12.00	12.00	7.00	4.88	1.12	0.25	2.88	2.688	3.62			4
304.8	304.8	177.8	123.95	28.5	6.35	73.2	68.28	92.0			4
14.50	14.62	8.50	6.50	1.00	0.25	3.62	3.750	4.88			8
368.3	371.4	215.9	165.10	25.4	6.35	92.0	95.25	124.0			8
16.50	16.62	9.62	7.50	1.12	0.25	4.12	4.250	5.38			8
419.1	422.2	244.4	190.50	28.5	6.35	104.7	107.95	136.7			8
18.50	18.62	10.50	8.00	1.25	0.25	5.00	5.375	6.62			8
469.9	473.0	266.7	203.20	31.8	6.35	127.0	136.53	168.2			8
21.50	21.62	12.25	9.50	1.38	0.25	6.19	6.375	7.62			8
546.1	549.2	311.2	241.30	35.1	6.35	157.2	161.93	193.6			8



# End Connections

## Butt Weld End Valves

Conforms to ASME B16.25

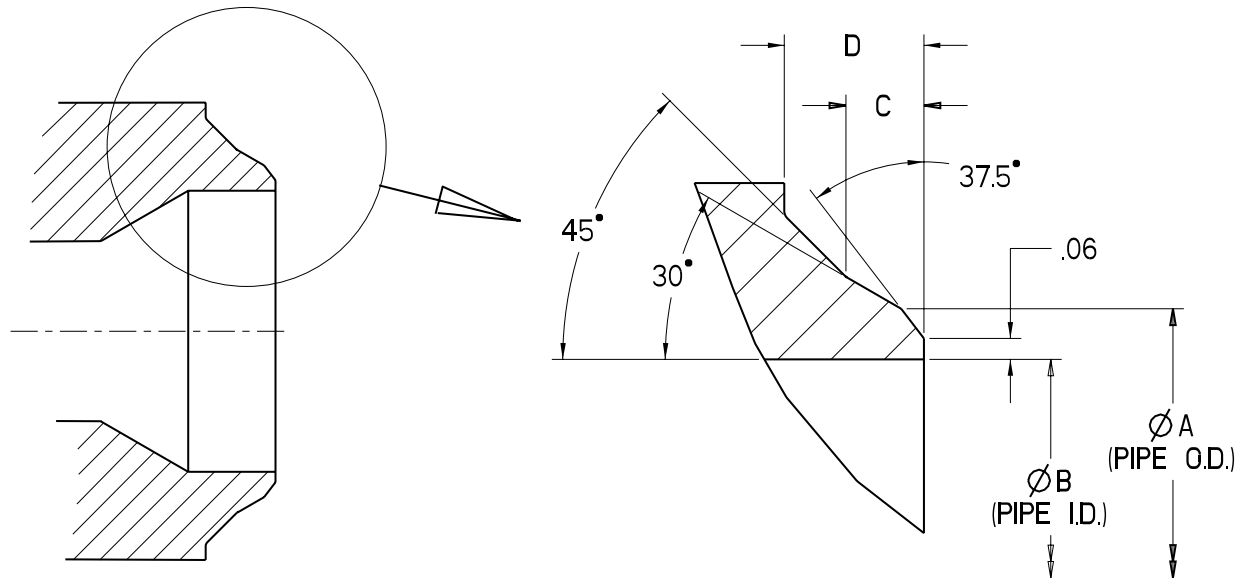

### Dimensions

SIZE				SCH 40			SCH 80			SCH 160			SCH XXS		
	A	B	C	D	B	C	D	B	C	D	B	C	D		
-04	NPS ½	0.84	0.622	0.16	0.22	0.546	0.22	0.29	0.466	0.28	0.37	0.252	0.44	0.59	
	DN 15	21.3	15.8	4.2	5.5	13.87	5.6	7.5	11.84	7.1	9.5	6.4	11.2	14.9	
-05	NPS ¾	1.05	0.824	0.17	0.23	0.742	0.23	0.31	0.614	0.33	0.44	0.434	0.46	0.62	
	DN 20	26.7	20.93	4.3	5.7	18.85	5.9	7.8	15.6	8.3	11.1	11.02	11.7	15.7	
-06	NPS 1	1.315	1.049	0.2	0.27	0.957	0.27	0.36	0.815	0.38	0.5	0.599	0.54	0.72	
	DN 25	33.4	26.64	5.1	6.8	24.31	6.8	9.1	20.7	9.5	12.7	15.21	13.6	18.2	
-07	NPS 1¼	1.66	1.38	0.21	0.28	1.278	0.29	0.38	1.16	0.38	0.5	0.896	0.57	0.76	
	DN 32	42.2	35.05	5.3	7.1	32.46	7.3	9.7	29.46	9.5	12.7	22.76	14.6	19.4	
-08	NPS 1½	1.9	1.61	0.22	0.29	1.5	0.3	0.4	1.338	0.42	0.56	1.1	0.6	0.8	
	DN 40	48.3	40.89	5.5	7.4	38.1	7.6	10.2	33.99	10.7	14.3	27.94	15.2	20.3	
-09	NPS 2	2.375	2.067	0.23	0.31	1.939	0.33	0.44	1.689	0.51	0.69	1.503	0.65	0.87	
	DN 50	60.3	52.5	5.9	7.8	49.25	8.3	11.1	42.9	13.1	17.4	38.18	16.6	22.2	
-10	NPS 2½	2.875	2.469	0.3	0.41	2.323	0.41	0.55	2.125	0.56	0.75	1.771	0.83	1.1	
	DN 65	73	62.71	7.7	10.3	59	10.5	14	53.98	14.3	19.1	44.98	21	28	
-11	NPS 3	3.5	3.068	0.32	0.43	2.9	0.45	0.6	2.624	0.66	0.88	2.3	0.9	1.2	
	DN 80	88.9	77.93	8.2	11	73.66	11.4	15.2	66.65	16.7	22.3	58.42	22.9	30.5	
-13	NPS 4	4.5	4.026	0.36	0.47	3.826	0.51	0.67	3.438	0.8	1.06	3.152	1.01	1.35	
	DN 100	114.3	102.26	9	12	97.18	12.8	17.1	87.33	20.2	27	80.06	25.7	34.2	



## End Connections

### Threaded End Valves

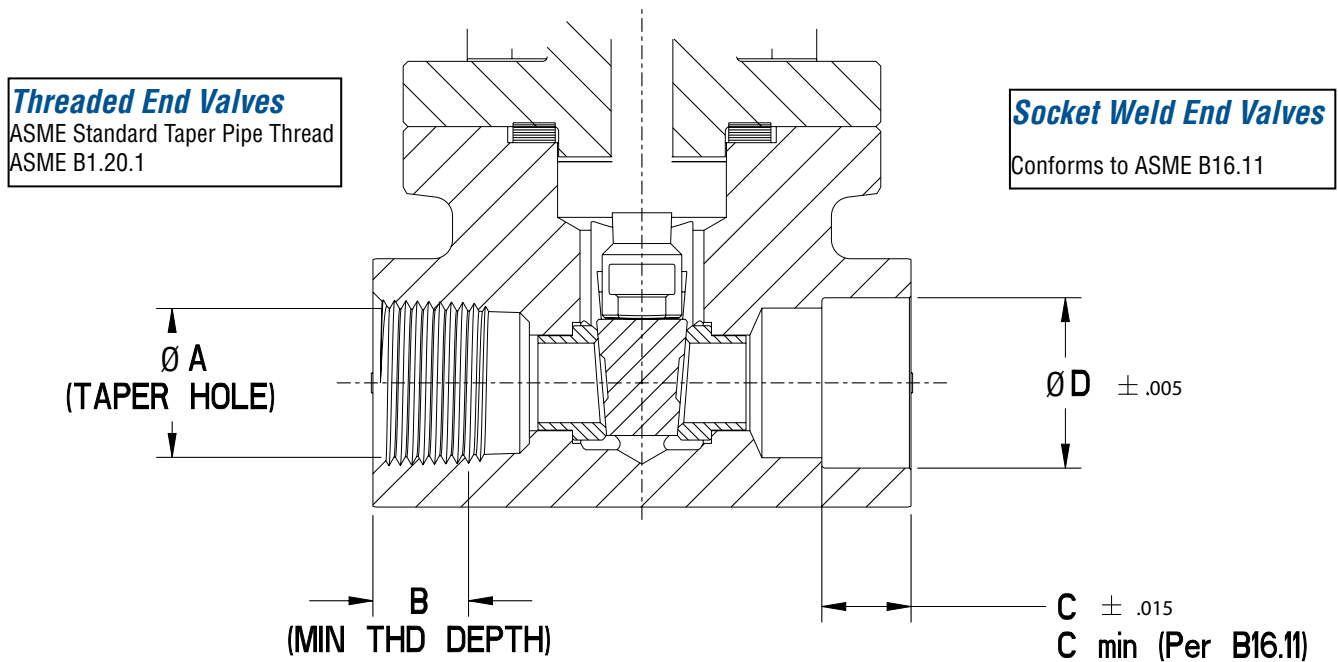

### Dimensions

			THREADED			SOCKET WELD		
SIZE			A	B	THD'S/IN	C	C MIN	D
-04	NPS	½	0.725	0.59	14	0.44	0.38	0.860
	DN	15	18.42	15.0		11.2	9.7	21.84
-05	NPS	¾	0.935	0.59	14	0.56	0.50	1.070
	DN	20	23.75	15.0		14.2	12.7	27.18
-06	NPS	1	1.173	0.75	11½	0.56	0.50	1.335
	DN	25	29.79	19.1		14.2	12.7	33.91
-07	NPS	1¼	1.518	0.78	11½	0.56	0.50	1.680
	DN	32	38.56	19.8		14.2	12.7	42.67
-08	NPS	1½	1.756	0.81	11½	0.56	0.50	1.920
	DN	40	44.60	20.6		14.2	12.7	48.77
-09	NPS	2	2.231	0.84	11½	0.69	0.62	2.411
	DN	50	56.67	21.3		17.5	15.8	61.24
-10	NPS	2½	2.666	1.25	8	0.69	0.62	2.911
	DN	65	67.72	31.8		17.5	15.8	73.94
-11	NPS	3	3.293	1.31	8	0.69	0.62	3.540
	DN	80	83.64	33.3		17.5	15.8	89.92





## $C_v$ Factors

TYPICAL SERIES NO.	NPS	½	¾	1	1¼	1½	2	2½	3	4
	DN	15	20	25	32	40	50	65	80	100
353, 363, 373, 353R, 12401C, 2801, 2811, 2831, 12111, 12161, 12321, 12401, 12421, 12521, 15111, 15373, 15801, ST15801, 32111, 35111, 42211MTG, 59851, 59951		9.6	9.7	20.3	80.5	91.6	117.6	174.0	203.9	230.0
13111, 13373, 16111, 43111MMP, SW-43211HF2		9.6	28.7	46.5	80.5	109.6	181.0	-	-	-
11103, 11403		9.6	28.7	46.5	80.5	109.6	181.0	242.3	322.7	-
2801B		9.6	9.7	20.3	-	109.6	117.6	-	-	-
CT-2801, ST-2801, TT-2801, CT-2831, ST-2831, TT-2831		6.5	9.0	27.7	-	78.0	-	-	-	-
CT-2901, CT, BT, TT, ST-12111		9.6	9.7	20.3	-	78.0	-	-	-	-
1033, 1043, 11603, 11683		11.8	28.7	32.0	83.2	109.6	181.0	-	-	-
66703, 66713		5.0	17.4	16.1	-	109.6	100.2	-	-	-
473, 483, 493, 801, 851, 2821, 12141, 12181, 12501, 12501C		2.4	4.3	7.3	14.2	20.4	23.1	-	-	-
473B, 483B, 493B, 12141B		2.2	5.7	5.2	-	21.1	20.5	-	-	-
22141CL, 22141F8M, 22141MT, 22493CL, 22493MT, 42241HF2		1.7	3.1	5.9	13.7	18.4	22.5	-	-	-
10103, 10403		3.4	7.3	11.9	15.5	28.2	46.9	-	85.1	-
SW-23141HF4, 43241MMP, 43241MTP		0.7	5.9	13.7	-	21.0	34.0	-	-	-
13141		3.0	6.8	14.5	17.2	24.4	37.6	-	-	-
CT-12141, ST-12141, TT-12141		2.4	4.3	7.3	-	20.4	-	-	-	-
12443		1.46	2.38	4.54	-	9.65	14.6	-	-	-
1971		2.6	4.5	11.9	21.0	31.4	52.0	-	-	-
22461		0.68	0.99	1.5	-	-	-	-	-	-
15141, 15493, 15821 SCH 160		3.1	3.3	5.9	-	13.8	21.4	-	-	-
1003, 1023, 10603, 10683		3.6	6.0	10.2	15.1	24.2	39.8	-	-	-
15443		1.46	2.38	4.54	-	11.5	13.0	-	-	-
1510, 1511, 1522 SCH 160		6.0	4.0	9.3	-	57.8	48.9	-	-	-
66723, 66733, 66793 SCH XXH		1.2	4.3	5.8	-	17.6	19.3	-	-	-
2510, 2511, 2522 SCH XXH		6.0	8.9	9.3	-	32.9	49.4	-	-	-
1331T, 1871T		2.9	3.8	8.1	15.3	18.4	25.5	-	-	-
2891T, 9841T		2.6	4.5	11.9	19.0	25.0	49.0	-	-	-
9821T, 9871T, 58431T		1.8	3.5	5.8	7.6	11.7	17.7	-	-	-
573, 583, 593, 701, 701ZL, B701, 718, B718, 32701, 82718		2.1	3.2	5.8	13.3	18.3	25.3	-	-	-
9091, B9091		3.6	6.7	11.8	20.2	26.1	43.3	-	-	-
SWB-43721HF2		0.7	5.9	11.8	-	22.6	32.6	-	-	-
4835		3.3	4.4	17.0	28.2	43.0	63.0	-	-	-
13701		3.2	6.9	16.0	18.3	25.5	36.9	-	-	-
54853, 54863		8.7	15.1	30.5	29.1	37.7	45.3	-	-	-
S74, S701		9.2	6.8	22.0	-	54.6	81.9	-	-	-
15593, 15701, B15701		3.2	3.3	6.3	13.3	11.0	19.6	-	-	-
1551, B1551		2.1	4.1	7.3	10.5	17.6	23.3	-	-	-
810, 811, 822		4.5	9.1	21.3	-	70.0	79.1	-	-	-

SCH 40 used for testing except as noted

## Flow Data Utilizing Cv Factors

FORMULAS		
TYPE FLOW	FLOW RATE	PRESSURE DROP
LIQUID	$Q = C_v \sqrt{\frac{\Delta P}{S}}$	$\Delta P = S \left(\frac{Q}{C_v}\right)^2$
GAS WHEN $\Delta P < .5P_1$	$q'_m = 22.6 C_v \sqrt{\frac{\Delta P \times P_1}{T_1 S_g}}$	$\Delta P = \frac{.00195 T_1 S_g}{P_1} \left(\frac{q'_m}{C_v}\right)^2$
WHEN $\Delta P \geq .5P_1$	$q'_m = \frac{13.9 P_1 C_v}{\sqrt{S_g T_1}}$	
DRY SATURATED STEAM		
WHEN $\Delta P < .5P_1$	$W = 2.97 C_v \sqrt{\Delta P \times P_1}$	$\Delta P = \frac{.113}{P_1} \left(\frac{W}{C_v}\right)^2$
WHEN $\Delta P \geq .5P_1$	$W = 1.82 C_v P_1$	
SUPERHEATED STEAM		
WHEN $\Delta P < .5P_1$	$W = \frac{2.97 C_v \sqrt{\Delta P \times P_1}}{(1 = .0007s)}$	$\Delta P = \frac{.113}{P_1} \left(\frac{W(1 + .0007s)}{C_v}\right)^2$
WHEN $\Delta P \geq .5P_1$	$W = \frac{1.82 C_v P_1}{(1 = .0007s)}$	

### Fluid Flow Nomenclature

- $C_v$ = Flow coefficient for valves and fittings.  
 $P_1$ = Absolute inlet pressure.  
 $\Delta P$ = Pressure drop in pounds per square inch. (PSI)  
 $Q$ = Liquid flow in gallons per minute. (GPM)  
 $q'_m$ = Rate of gas flow in cubic feet per minute at standard conditions, 14.7 psia and 60°F. (SCFM)  
 $S$ = Specific gravity of flowing liquid relative to water at 60°F.  
 $S_g$ = Specific gravity of gas relative to air.  
 $s$ = Number of degrees of superheat for steam in °F.  
 $T_1$ = Absolute inlet temperature in degrees Rankine °R.  
 $W$ = Steam or vapor flow rate in pounds per hour. (LBS./HR.)

## Flow Data Utilizing Cv Factors (Metric Version)

FORMULAS		
TYPE FLOW	FLOW RATE	PRESSURE DROP
LIQUID	$Q = .865 C_v \sqrt{\frac{\Delta P}{S}}$	$\Delta P = 1.34S \left(\frac{Q}{C_v}\right)^2$
GAS WHEN $\Delta P < .5P_1$	$q'_H = 414.97 C_v \sqrt{\frac{\Delta P \times P_1}{T_1 S_g}}$	$\Delta P = \frac{5.81 \times 10^{-6} T_1 S_g}{P_1} \left(\frac{q'_m}{C_v}\right)^2$
WHEN $\Delta P \geq .5P_1$	$q'_H = \frac{255.2 P_1 C_v}{\sqrt{S_g T_1}}$	
DRY SATURATED STEAM		
WHEN $\Delta P < .5P_1$	$W = 19.53 C_v \sqrt{\Delta P \times P_1}$	$\Delta P = \frac{.00262}{P_1} \left(\frac{W}{C_v}\right)^2$
WHEN $\Delta P \geq .5P_1$	$W = 11.97 C_v P_1$	
SUPERHEATED STEAM		
WHEN $\Delta P < .5P_1$	$W = \frac{19.1 C_v \sqrt{\Delta P \times P_1}}{(1 = 0.00123s)}$	$\Delta P = \frac{0.00274}{P_1} \left(\frac{W(1 + 0.00123s)}{C_v}\right)^2$
WHEN $\Delta P \geq .5P_1$	$W = \frac{11.71 C_v P_1}{(1 = 0.00123s)}$	

### Fluid Flow Nomenclature

- $C_v$ = Flow coefficient for valves and fittings.  
 $P_1$ = Absolute inlet pressure. (BAR)  
 $\Delta P$ = Pressure drop in bars.  
 $Q$ = Liquid flow in cubic meters per hour  
 $q'_m$ = Rate of gas flow in cubic meters per minute at standard conditions, 1.01 BAR @ 15.6 °C  
 $S$ = Specific gravity of flowing liquid relative to water at 16°C.  
 $S_g$ = Specific gravity of gas relative to air.  
 $s$ = Number of degrees of superheat for steam in °C.  
 $T_1$ = Absolute inlet temperature in degrees Kelvin (°K).  
 $W$ = Steam or vapor flow rate in kilograms per hour. (KGS./HR.)

**MATERIAL COMPATIBILITY CHART**

	A105, A182, F5, F9, F11, F22	A182, F316	13 CR	TYPE 316	Monel	Hastelloy	Teflon	Viton	Neoprene	Ethylene Propylene	Buna N	Flexible Graphite Packing
<b>1- Acceptable for Use</b>												
<b>0 - Not Acceptable for Use</b>												
<b>Chemical</b>												
Acetaldehyde	1	1	1	1	1	1	1	0	0			
Acetate Solvents	1	1	1	1	1	1	1	0	0	1	0	
Acetic Acid (100%)	0	1	0	1	1	1	1	1	0	1	0	1
Acetic Acid (crude)	0	1		1	1							1
Acetic Acid Vapors	0	1	0	1	1	1						1
Acetic Anhydride	0	1	0	1	1	1	1	0				1
Acetone	1	1	1	1	1	1	1	0	0	1	0	1
Air	1	1	1	1	1	1	1	1	1	1	1	1
Alcohol - Amyl	1	1		1	1	1	1				1	1
Alcohol - Butyl	1	1	1	1	1	1	1				1	1
Alcohol - Diacetone	1	1		1	1	1	1				1	1
Alcohol - Ethyl	1	1	1	1	1	1	1	1	1	1	1	1
Alcohol - Isopropyl	1	1		1	1	1	1				1	1
Alcohol - Methyl	1	1	1	1	1	1	1	0	1	1	1	1
Alcohol - Oleyl				1				1			1	
Alkaform		1		1								
Alum 10%	0	1	1	1	1	1	1	1	1	1	1	1
Alumina				1	1	1	1	1	1	1		
Aluminum Acetate	0	1		1	1	1						
Aluminum Chloride	0	1	0	1	1	1	1	1	1	1	1	1
Aluminum Fluoride		1		1	1	1	1	1	1	1		
Aluminum Hydroxide		1	1	1	1	1	1	1	1	1		
Aluminum Sulfate 10% (boiling)	0	1		1	1	1	1	1	1	1	1	
Aluminum Sulfate, Saturate (boiling)	0	1		1	0	1	1	1	1	1		
Aluminum Sulfate, Saturate (room)	0	1		1	1	1	1	1	1	1		
Amines	1	1		1	1	1	0	1	1	0		
Ammonia (gas or liquid)	1	1		1	1	1	1				1	
Ammonia, Dry	1	1	1	1	1	1	0	1	1	0		
Ammonium Bicarbonate	1	1		1	0	1	1					
Ammonium Carbonate	1	1		1	1	1	1	1				
Ammonium Chloride	0	1	0	1	1	1	1	1	1	1	1	
Ammonium Diphosphate		1	1	1	1	1	1	1	1	1		
Ammonium Hydroxide	1	1	1	0	1	1	1	1	1	1	1	1
Ammonium Hydroxide		1	1			1	1	1	1	1		
Ammonium Monosulfate		1	1		1	1	1	0	1	1		
Ammonium Nitrate	1	1		1	0	0	1	1	1	1	1	1
Ammonium Oxalate	1	1		1	1	1						
Ammonium Persulfate	0	1		1	0	0						
Ammonium Phosphate(di)	1	1		1	1	1	1					
Ammonium Phosphate(mono)	1	1		1	0	1	1	1	1	1	1	1
Ammonium Phosphate(tri)	1	1		1	1	1		1				
Ammonium Sulfate	0	1		1	1	1						1
Ammonium Thiocyanate						1	1					
Amyl Acetate	1	1	1	1	1	1	1	0	0	1	0	
Amyl Chloride	1	1		1	1	1	1	0	0	0		
Aniline Dyes		1		1	1	1	1					
Aniline Hydrochloride	0		0	1	1	1						
Aniline Oils		1		1	1	1	0					
Aniline Sulfite		1		1	1	1	0		0			
Aniline to 80F	1	1	1	1	1	1	0	0	0	0	1	
Antimony Chloride				1	0	1						
<b>Chemical</b>												
Antimony Trichloride	0	0		0	1		1	1				
Antioxidants					1		1	1				
Archlor	1											
Arsenic Acid	0	1		1	0		1	1	1	1	1	1
Arsenic Trichloride					1		1					
Asphalt	1	1		1	1		1	1	1	0	1	
Barium Carbonate	1	1		1	1	1	1	1	1	1	0	
Barium Chloride	0	1		1	1	1	1	1	1	1	1	
Barium Hydrate		1		1	1	1						
Barium Hydroxide	1	1	1	1	1		1	1	1	1	1	
Barium Nitrate	1	1		1								
Barium Sulfate		1		1	1		1	1	1	1	1	
Barium Sulfide	1	1	1	0		1	1	1	1	1	1	
Beer	0	1	1	1	1	1	1	1	1	0	1	
Beet Sugar Liquor	1	1	1	1	1		1	1	1	1	1	
Benzaldehyde	1	1		1	1		1	0	0	1	0	
Benzene(Benzol)	1	1	1	1	1	1	1	1	0	0	0	1
Benzensulfonic Acid					1		1					
Benzoic Acid	0	1		1	1	1	1	1	0	0	0	
Black Liquor	1	1		1	1		1	1	1	1	1	
Blast Furnace Gas			1						1			
Bleaching Powder, Wet	0	1		1	0	0	1		1	1	1	
Boiler Acid - Phosphate type					1				1			
Boiler Compounds (ph 8.0)					1				1			
Borax Liquors	1	1	1	1	1	1	1	1	0	1	1	
Bordeaux Mixture					1				1			
Boron Trichloride	1											
Boron Trifluoride	0	1		1								
Brine - Alkaline	0	1		1	1		1	0	1	0		
Bromine(dry)	0	0	0	0	0	1	0	1	0	0	1	
Bromine(wet)		1	0	1		0	1	0	0	0	1	
Butadiene	1	1	1	1	1		1				1	
Butane	1	1	1	1	1		1	1	1	1	0	1
Buttermilk	0	1		1	0	1	1	1	1	1	1	1
Butyl Acetate	1	1	1	1	1	1	1	0	0	0	0	
Butyl Catechol Tert					1							
Butyl Cellusolve		1		1	1							
Butyl Chloride 100%	0	1		1	1	1	1					
Butyl Stearate		1		1								
Butylene		1		1	1		1			0		
Butyl-p-Aminopheno					1							
Butyric Acid	0	1		1	1	1	1	1		1		
Cadmium Sulfate		1		1	1	1						
Calcium Acetate		1		1	1							
Calcium Bisulfite	0	1	0	1	0	1	1	1	1	1	1	1
Calcium Carbonate		1	1	1	1		1	1	1	1	1	1
Calcium Chlorate	1	1		1	1	1						
Calcium Chloride	1	1		1	1	1	1	1	1	1	1	1
Calcium Hydroxide	1	1	1	1	1	1	1	1	1	1	1	1
Calcium Hypochlorite	0	1	0	1	0	1	1					1
Calcium Nitrate (40%)		1		1	1							
Calcium Sulfate	1	1	1	1	1	1	1	1	1	1	1	1

**MATERIALS COMPATIBILITY CHART**

	A105, A182, F5, F9, F11, F22	A182, F316	13 CR	TYPE 316	Monel	Hastelloy	Teflon	Viton	Neoprene	Ethylene Propylene	Buna N	Flexible Graphite Packing
<b>1- Acceptable for Use</b>												
<b>0 - Not Acceptable for Use</b>												
<b>Chemical</b>												
Calgon		1	1	1	1	1	1	1	1	1	1	
Camphene	1											
Camphor	1	1	1	1	1	1						
Cane Sugar Liquor	1	1	1	1	1	1	1	1	1	1	1	1
Carbolic Acid (phenol)	1	1	1	1	1	1	1	0	0	0	1	
Carbon Dioxide(dry)	1	1	1	1	1	1	1					1
Carbon Dioxide(wet)		1	1	1	1							1
Carbon Disulfide	1	1	1	1	1	1	1	0	0	0	1	
Carbon Monoxide	1	1	1	1	1	1	1					1
Carbon Tetrachloride	1	1	1	1	1	1	1	0	0	0	1	
Carbonated Beverages		1	1	1	1	1	1					
Carbonated Water		1	1	1	1	1	1	1	1	1	1	
Carbonic Acid	1	1	1	1	1	1						
Castor Oil		1	1	1	1	1	1	1	1	1	1	
Catechol					1							
Caustic Soda		1	1	1	1	1	1	1				
Cellosolve (butyl or ethyl)		1	1	1	1							
Cellosolve (methyl)		1	1	1								
China Wood Oil (tung)	1	1	1	1	1	1	1	0	0	1		
Chloracetic Acid	0	0	0	0	1	1	1	0	0	0		
Chlorbromomethane		1	1	1								
Chlorex		0	1	0	1							
Chloric Acid	0											
Chlorinated Water	0	1	1	0	0	1						
Chlorine (dry)	1	0	1	1	1	1						1
Chlorine (wet)	0	0	0	0	0	1						1
Chlorobenzene	1	1	1	1				0				
Chloroethane	1											
Chloroethylbenzene												
Chloroform (dry)	1	1	1	1	1	1	1	0	0	0	1	
Chlorosulfonic Acid (dry)	1	1	1	1	1	1						1
Chlorox					0	1	0	1	0			
Chrome Plating Solution		1	1	0								
Chromic Acid (contains SO3)	0	1	0	1	0	0	1	0	1	0		
Chromic Acid (free of SO3)	0	1	0	1	0	1	0	1	0			
Chromium Sulfate	0	1	1	1	1	1						
Cider		1	1	1	1			1				
Citric Acid	1	1	0	1	1	1	1	1	1	1	1	1
Clay Slurries	1											
Coal Tar (creosote)	1	1	1	1	1	1						1
Coca Cola Syrup	0	1	1									
Coconut Oil	1	1	1	1	1	1						
Cod Liver Oil		1	1	1				1				
Coffee	0	1	1	1	1	1	1	1	1	1	1	
Coke Oven Gas	1	1	1	1	1	1	1	1				1
Copal Varnish		1	1	0	1							
Copper Acetate	0	1	1									
Copper Carbonate		1	1	1								
Copper Chloride	0	0	0	0	1	1	1	1	1	1	1	
Copper Cyanide	0	1	1	1	1	1						
Copper Nitrate	0	1	1	0	0	1	1	1	1	1	1	
Copper Sulfate	0	1	1	1	1	1	1	1	1	1	1	
Core Oil	1	1	1	1	1	1						
Cornstarch Slurries		2							1			
Cottonseed Oil		1	1	1	1	1			1			
Cream of Tartar		1	1	1								
Cresylic Acid	0	1	1	1	1	1	1	0	0	0		
Cupric Chloride	0	0	0	1	0	0	1					
Cupric Nitrate		1	1	0	0							
Cyanogen Chloride	1											
Cyanohydrin	1											
Cyclohexane	1	1	1	1	1	1	1					1
Cyclohexylamine				1								
DDT		1	1			1						
Detergents		1	1	1	1							
Developing Solutions	0	1	1	1	1							
Dextrose		1	1									
Diacetone					1	1					0	
Diamylamine					1	1	1	1	1	1		
Dichloroethane	0	1						0	0	0		
Dichloropentane				1				0	0			
Diesel Oil (light)	1	1	1	1	1	1	1	0	1	1		
Diethanolamine				1	1	1	1	1	1	1		
Diethyl Sulfate	1	1		1	1	1						
Diethylbenzene								0	0	0		
Diethylene Glycol	1	1	1	1	1	1	1	1	1	1	1	
Dimethyl Phthalate							1	0	0			
Dinitrochlorobenzene	0											
Dioctyl Phthalate	0											
Dioxane (dry)	1	1	1	1	1	1	1					
Dipentene - Pinene	1	1	1	1	1	1	1	1	0	1		
Diphenyl	1	1	1	1	1	1	1	0	1			
Diphenyloxide					1							
Disobutyl Ketone	1	1			1							1
Distilled Water		1	1	1	1			1				
Distillery Wort		1	1									
Doctor Solution		1	1	1				1				
Dowtherm	1	1	1	1	1	1	1	0	0	0	1	
Dyewood Liquor	0	1	1									
Embalming Fluid	1											
Enamel					1	1	1	0	1			
Esters					1							
Ethanolamine	1	1	1	1	1	1	1	1	1	1		
Ether, Dibutyl	1	1	1	1	1	1	1	0	0			
Ether, Diethyl	1	1	1	1	1	1	1	0	0			
Ether, Petroleum	1	1	1	1	1	1	1	0	0			
Ethyl Acetate	1	1	1	1	1	1	1	0	0	1		
Ethyl Acrylate	1	1	1	1	1	1						
Ethyl Cellulose	1						1	1	1			
Ethyl Chloride (dry)	1	1	1	1	1	1	1	0	1	1	1	
Ethyl Mercaptan	1	1	1	1								
Ethyl Sulfate	1	1	1	1	1	1	1	1	1	1		
Ethylbenzene					1	1	0	0				
Ethylene (liquified)		1	1	1								
Ethylene Chloride		1	1	1								1
Ethylene Chlorohydrin	1											
Ethylene Dibromide	1	1										



**MATERIALS COMPATIBILITY CHART**

	A105, A182, F5, F9, F11, F22	A182, F316	13 CR	TYPE 316	Monel	Hastelloy	Teflon	Viton	Neoprene	Ethylene Propylene	Buna N	Flexible Graphite Packing
<b>1- Acceptable for Use</b>												
<b>0 - Not Acceptable for Use</b>												
<b>Chemical</b>												
Ethylene Dichloride	1	1	1	1	1				1			
Ethylene Glycol	1	1	1	1	1	1	1	1	1	1	1	1
Ethylene Oxide	1	1	1	1	1	1	1		0	0	1	
Fatty Acids	0	1	1	1	1	1	1					1
Ferric Chloride	0	0	0	0	0	0	1	1	1	1	1	1
Ferric Hydroxide					1	0						
Ferric Nitrate	0	1	0	1	0	0	1	1	1	1		
Ferric Sulfate	0	1		1	0	0	1	1	1	1		
Ferrous Ammonium Citrate						1						
Ferrous Chloride solution	0	0	0	0	0	1	1	1	1	1	1	1
Ferrous Sulfate 10%	0	1		1	1	1	1	1	1	1	1	1
Filter Aid					1				1			
Fish Oil	1	1		1	1		1				1	
Flue Gases	1	1		1	1	1	1					
Fluoboric Acid		1		1	1		1	1	1		1	
Fluorine (dry)	1	1	1	1	1	1	0					1
Fluosilicic Acid	0	1		1	1	1	1	1				
Formaldehyde cold	1	1		1	1	1	1	1	1			1
Formalin		1	1									
Formic Acid	0	1		1	1	1	1	1	1			1
Freon (dry)	1	1		1	1	1	1	1	1			1
Freon (wet)	0	1	1	1	1	1	1	1	1			1
Fruit Juices	0	1	0	1	1	1	1	1	1	1	1	1
Fuel Oil	1	1	1	1	1	1	1	1	0	1	1	1
Fumaric Acid			1				1	1	1		1	
Furfural	1	1	1	1	1	1	1		1	0	1	1
Gallic Acid 5%	0	1	1	1	1	1	1	1	1	1	1	1
Gasoline (antioxidant)					1				0			
Gasoline (refined)	1	1	1	1	1	1	1	1	0	1	1	1
Gasoline (sour)	1	1		1	0	1	1	1	0	1	1	1
Gelatin	1	1		1	1		1	1	1	1	1	1
Ginger Ale	0	1		1								
Glauber's Salt		1		1	1			1				
Glucose	1	1	1	1	1		1	1	1	1	1	1
Glue (most)	1	1	1	1	1	1		1	1	1	1	1
Glutamic Acid		1		1		1						
Glycerine	1	1	1	1	1	1	1	1	1	1	1	1
Glycerol	1	1	1	1	1	1	1	1	1	1	1	1
Grease (edible)	1	1		1	1		1		0	1		
Green Sulfate Liquor		1	1	1	1			1				
Gypsum		1		1								
Hagan Solution					1							
Heptane (liquified)		1	1	1	1		1	1	0			
Hexamine		1		1		1						
Hexane	1	1		1	1	1	1					1
Hydrobromic Acid	0	0	0		0	1	1	1	1		0	1
Hydrofluoric Acid (5%)	1	0	0	0	1	1	1	1	1	0	1	
Hydrofluoric Acid (50%)	0	0	0	0	0	1	1	1	1	0	1	
Hydrofluoric Acid (60%)	0	0	0	0	1	1	1	1	1	0	1	
Hydraulic Oil	1	1		1	1	1	1	1	0	1		
Hydrazine Hydrate		1		1	1							
Hydrocarbons (alkylated)					1	1	1	1		1		
Hydrocarbons (chlorinated)						1	1	0	1			
<b>Chemical</b>												
Hydrocarbons (sweet)												1
Hydrochloric Acid, Cold 10%	0	0	0	0	0	1	1	1	1	1		1
Hydrocyanic Acid 100%	1	1		1	1	1	1	1	1	1	1	1
Hydrofluosilicic Acid 100%	0	1		1	1	1	1	1	1			1
Hydrogen Chloride (gas)	1	1		1	1	1	1					
Hydrogen Fluoride	1											
Hydrogen Gas	1	1	1	1	1			1	1	1	1	1
Hydrogen Peroxide 33%	0	1	0	1	1	1	1	0	1	1	0	1
Hydrogen Sulfide (dry) 100%	0	1	1	1	1	1	1	1	1	1	1	1
Hydrogen Sulfide (wet) 100%	0	1	1	1	0		1	1	1	1	1	1
Hydroquinone	1	1		1	1							
HYPO (hyposulfite soda)		1	1	1	1							
Idoform	0	1		1			1	1	0			
Ink	0	1		1	1		1	1				1
Iodine solution	0	1		1	0	1	1	1				1
Isobutane		1		1	1		1	0	0			
Isobutyl Acetate		1		1	1		1					
Isoctane	1	1		1	1	1	1	1	0			1
Isopropyl Acetate		1		1			1	0	0			
Isopropyl Ether	1	1		1	1	1	1	0	0			1
Jet Fuel	1	1		1	1	1	1	1	0	1	1	1
Kerosene	1	1	1	1	1	1	1	1	1	0	1	1
Ketchup	0	1		1	1	1	1	1	1	1		1
Ketones 100%	1	1		1	1	1	1	0	0		0	1
Lacquer Solvents	1	1	1	1	1	1	1	0	0	0	0	1
Lactic Acid diluted	0	1	0	1	0	1	1	1	1		0	1
Lard oil	1	1		1	1	1		1				1
Latex	1	1		1								
Lead Acetate	0	1		1	1	1	1	1				
Lead Nitrate	1								1			
Lead Sulfamate									1			
Levulinic Acid						1						
Lime Slurry	1	1		1	1		1	1	1	1	1	1
Lime Sulfur		1		1	1		1	1	1	1	1	1
Linoleic Acid	0	1		1	1		1					1
Linseed Oil	1	1	1	1	1	1	1	1	0	0	1	1
Liquid Petroleum Gas (L. P. G.)	1	1		1	1	1	1		0			1
Lithium Chloride	1	1		1	1		1					1
Lithium Hydroxide		1		1		1						
Lubricating Oils	1	1	1	1	1			1		0	1	
Magnesium Carbonate	1	1		1	1	1	1	1	1	1	1	1
Magnesium Chloride	1	1		1	1	1	1	1	1	1	1	1
Magnesium Hydroxide	1	1	1	1	1	1	1	1	1	1	1	1
Magnesium Nitrate		1	1	1		0						
Magnesium Oxide						1			1			
Magnesium Oxychloride	0	0		0								
Magnesium Sulfate	1	1		1	1	1	1	1	1	1	1	1
Maleic Acid 100%	1	1	0	1	1	1	1	1	1	1		1
Maleic Anhydride						1						
Malic Acid		1		1	1	1	1	1	1	1	1	1
Malt Beverages					1		1	1	1	1	1	
Manganese Carbonate		1		1	1							
Manganese Chloride		1		1	1							

**MATERIALS COMPATIBILITY CHART**

Chemical	A105, A182, F5, F9, F11, F22	A182, F316	13 CR	TYPE 316	Monel	Hastelloy	Teflon	Viton	Neoprene	Ethylene Propylene	Buna N	Flexible Graphite Packing
	1- Acceptable for Use 0 - Not Acceptable for Use											
Manganese Sulfate	1	1	1	1	1	1						1
Mash		1	1	1	1	1						
Mayonnaise	0	1	1	1	1	1	1	1	1		1	
Melamine Resins		0	0	1		1						
Meraptobenzothiazole				1								
Mercaptans	1											
Mercuric Bichloride		1	1		0							
Mercuric Chloride	0	0	0	0	1	1	1	1	1	1	1	1
Mercuric Cyanide	0	1	1	1		1						1
Mercurous Nitrate	0	1	1		0							
Mercury	1	1	1	1	1	1	1	1	1	1	1	1
Mercury Salts		0	0			1	1	1	1			
Mesityl Oxide	1											
Methane	1	1	1	1	1	1	1				1	1
Methyl Acetate	1	1	1	1	1	1		0				1
Methyl Acrylate		1	1									
Methyl Benzene					1							
Methyl Cellosolve	1	1	1	1	1	1	1	1	0	0	1	
Methyl Chloride (dry)	0	1	1	1	1	1	1	0	0	0		
Methyl Ethyl Ketone	1	1	1	1	1	1	1	0	0	0	0	1
Methyl Formate 100%	1	1	1	1	1	1	1			0		
Methyl Isobutyl Ketone		1	1	1	1	1	1	0	0			
Methyl Ketone												
Methyl Methacrylate	0											
Methylene Chloride	1	1	1	1	1	1						1
Milk	0	1	1	0		1	1	1	1	1	1	1
Mine Water	0	1	1	0	0	1	1	1	1	1		
Mineral Oil U. S. P. pure	1	1	1	1	1	1	1	1	0	1	1	
Molasses	1	1	1	1	1	1	1	1	1	1	1	1
Monochloroacetic Acid	0	0	0	0	1	1	1	1				1
Monochlorobenzene			1			1		0	0	1		
Monochlorodifluoromethane		1	1									
Monoethanolamine	1											
Mustard	0	1	1								1	
Nalco Solution					1			1				
Naphtha	1	1	1	1	1	1	1	1	0			1
Naphthalene 100%	1	1	1	1	1	1	1	1	0	0	1	
Naphthalenic Acid	0	1	1									
Natural Gas	1	1	1	1	1	1	1	1	1	0	1	1
Nickel Acetate									1			
Nickel Chloride	0	1	0	1	1	1	1	1	1	1	1	1
Nickel Nitrate		1	1	0	1	1	1	1	1	1	1	
Nickel Plating Solution		0	0	0								
Nickel Sulfate	0	1	1	1	1	1	1	1	1	1	1	1
Nitric Acid (10%)	0	1	0	1	0	1	1	0	0	0	1	
Nitric Acid (30%)	0	1	0	1	0	1	1	0	0	0		
Nitric Acid (60%)	0	1	0	1	0	1	1	0	0	0		
Nitric Acid (80%)	0	1	0	0	0	1	1	0	0	0		
Nitric Acid (crude)	0	0	0	0	0	0	1	0	0	0	1	
Nitrobenzene	1	1	1	1	1	1	1	0	0	0		
Nitroethane	1											
Nitropropane	1											
Nitrous Acid	0											
Nitrous Oxide		0							0	0		
Nordihydroguaracetic Acid									0			
Oakite									1			
Octyl Alcohol									1			
Oleic Acid 100%	1	1	1	1	1	1	1	1	0		1	
Oleum spirits	1	1	1	0	1	1	1	0	0	0		
Olive Oil	0	1	1	1	1	1	1	1				
Organic Esters									1			
Oxalix Acid cold	0	1	0	1	1	1	1	1	1	1	1	1
Oxygen	1	1	1	1	1	1	1	1	1	1	1	
Ozone (wet)	0	1	1	1	1	1						
Palm Oil	0	1	1	1	1	1			1			
Palmitic Acid									1			
Paraffin	1	1	1	1	1	1	1	1	0	1		
Paraffin Oil	1	1	1	1	1	1	1	1			1	
Para-formaldehyde									1		0	
Paraldehyde									1		0	
Paregoric Compound	0	1	1									
Parez 607	0	0	0					1				
Peanut Oil		1	1	1								
Pectin	0											
Pelargonic Acid									0			
Penicillin Solution	0								1		1	
Pentane			1	1	1	1	1	1	0	1		
Perfume	0	1	1									
Petroleum Oils (refined)	1	1	1	1	1							
Petroleum Oils (sour)		1	1	0	1							
Phenol 100%	1	1	1	1	1	1	1	0	0	1		
Phenolic Resins		1	1									
Phenolic Sulfonate	1											
Phenosulfonic Acid		1	1	1								
Phoscaloid									1			
Phosgene	1											
Phosphoric Acid, <45%	0	1	0	1	0	1	1	1	1	1		
Phosphoric Acid, 0%-45%	0	1	0	1	1	1	1	1	1			1
Phosphoric Acid, Crude	0	1	0	1	0	1	1	1	1			
Phosphoric Anhydride	0	1	1									
Phosphorus Trichloride		1	1	0								
Phosphorus, Molten	1	1	1	1	1							1
Phtalic Acid	0								1	1		
Phtalic Anhydride		1	1	1	1				1			
Picric Acid, solution	0	1	1	0	1	1	1	1				1
Pine Oil	1	1	1	1	1	1	1	1	0	0	1	
Pitch									1		0	
Plating Solution									0			
Potassium Alum									1	1	1	
Potassium Antimonate									1			
Potassium Bicarbonate		1	1							1		
Potassium Bichromate		1	1	0								
Potassium Bisulfate									0			
Potassium Bromide	0	1	1	1	1	1	1	1	1	1	1	1
Potassium Carbonate	1	1	1	1	1	1	1	1	1	1	1	1

**MATERIALS COMPATIBILITY CHART**

	A105, A182, F5, F9, F11, F22	A182, F316	13 CR	TYPE 316	Monel	Hastelloy	Teflon	Viton	Neoprene	Ethylene Propylene	Buna N	Flexible Graphite Packing
<b>1- Acceptable for Use</b>												
<b>0 - Not Acceptable for Use</b>												
<b>Chemical</b>												
Potassium Chlorate	1	1		1	1	0	1	1	1	1	1	
Potassium Chloride	0	1	1	1	1	1	1	1	1	1	1	
Potassium Chromate	1	1		1	1	1	1	1	1	1	1	1
Potassium Cyanide	1	1	1	1	1	1	1	1	1	1	1	
Potassium Dichromate	1	1		1	1	1	1	1	1	1	1	
Potassium Diphosphate		1		1	1			1	1	1		
Potassium Ferricyanide	0	1		1	1	1	1					
Potassium Ferrocyanide	0	1		1	1	1	1					
Potassium Hydrate		1		1	1	1						
Potassium Hydroxide	1	1	1	1	1	1	1	1	1	1		1
Potassium Hypochlorite	0	1		1	0	0	1					
Potassium Iodide	0	1		1	1	1	1	1	1	1	1	
Potassium Monophosphates		1		1	1		1	1	1	1	1	
Potassium Nitrate	1	1	1	1	1	1	1	1	1	1	1	1
Potassium Oxalate		1		1		1						
Potassium Permanganate	1	1		1	1	0	1	1	1	1	1	
Potassium Peroxide		1		1								
Potassium Phosphate (acid)	1				1		1	1		1		
Potassium Phosphate (alkaline)	1				1		1	1	1	1		
Potassium Sulfate	1	1		1	1	1	1	1	1	1	1	1
Potassium Sulfide	0	1	1	1	0		1	1	1		1	1
Potassium Triphosphate		1		1	1		1	1	1	1		
Prestone					1							
Producer Gas		1	1	1	1		1	1	0			
Propane Gas	1	1	1	1	1		1	1		0	1	1
Propane, Liquified		1		1	1		1	1				
Propene, Liquified					1							
Propyl Alcohol	1	1	1	1				1				
Propylene Dichloride	1				1			0				
Propylene Glycol	1	1		1	1	1	1	1				1
Propylene Oxide	1	1		1			1					
Pyrethrum Sol.					1							
Pyridine	1	0	1	0			1	0	0		0	
Pyrogalllic Acid	1	1		1	1	1	1	1				
Pyroligneous Acid	0											
Qualsol 80					0							
Querbracho					1			1				
Quinine Bisulfate	0	1		1	1	1						
Quinine Sulfate	0	1		1	1	1						
Resorcinol					1		1					
Rosin (dark)	0	1	1	1	1	1	1					
Rosin (light)	0	1		1	1	1	1					
Rustang					1							
Sal Ammoniac	0	1		1	1	1	1	1				
Salicylic Acid	0	1		1	1	1	1	1				1
Santobrite					1		1	1	1		1	
Santomerse					1							
Santophen					0							
Santosite					0							
Shellac	1	1		1	1	1	1				1	1
Shellac Orange		1	1	1	1		1				1	
Silicon Tetrachloride	1				1							
Silicon Tetraiodide					1							
<b>Chemical</b>												
Silver Bromide	0	1		1	1	1	1	1				
Silver Chlorate	0	0		0	1	0						
Silver Cyanide	0	1		1	1	1	1	1				
Silver Nitrate		1		1		1	1	1	0	1	0	
Silver Plating Solution		1		1								
Sizing, Acid						0						
Sizing, Alkaline						1						
Sludge Acid		1		1	0							
Soap (molten)	1	1	1	1	1	1	1	1	1	1	1	
Sodium Acetate	1	1		1	0	1	1	1		1		1
Sodium Acid Sulfate							1		1	1	1	1
Sodium Aluminate	1	1		1	1		1	1	1	1	1	1
Sodium Benzoate					1	1						
Sodium Bicarbonate		1	1	1	1	1	1	1	1	1	1	1
Sodium Bichromate		1		1	1	0						
Sodium Bisulfate	0	1		1	1	1	1	1	1	1	1	1
Sodium Bisulfite		1		1	0		1	1	1	1	1	1
Sodium Borate		1	1	1	1	1	1	1	1	1	1	1
Sodium Bromide	0	1	0	1	1	1	1	1	1	1	1	1
Sodium Chloride	1	1	1	1	1	1	1	1	1	1	1	1
Sodium Chromate	2	1		1		1	1	1	1	1	1	1
Sodium Citrate	3	1		1	1	1	1	1	1	1	1	1
Sodium Coarbonate (soda ash)	1	1	1	1	1	1	1	1	1	1	1	1
Sodium Cyanide	0	1	1	1	0		1	1	1	1	1	1
Sodium Dichromate	1	1		1			1	1	1	1	1	1
Sodium Diphosphate		1		1	1							
Sodium Diphosphate		1		1	1				1			
Sodium Ethylate	1											
Sodium Ferrocyanide						1	1					
Sodium Fluoride	0	1	0	1	1		1	1	1	1	1	1
Sodium Glutamate	1											
Sodium Hydroxide 0%-20%	1	1	1	1	1	1	1	1	0	1	1	1
Sodium Hydroxide 20% or Hot	0	1	0	1	1	1	1	1	0	1	1	1
Sodium Hydrsulphite						1	1					
Sodium Hypochlorite 20%	0	0	0	0	0	0	1					1
Sodium Hyposulfite	0	1		1	1	1	1		1			
Sodium Lactate	0											
Sodium Methylate						1						
Sodium Monophosphate		1		1	1		1		1	1	1	
Sodium Naphthsulfonate						1						
Sodium Nitrate	1	1	1	1	1	1	0	1	1	1	1	1
Sodium Nitrite		1	1	1						1	1	
Sodium Oleate	1											
Sodium Orthosilicate						1	1		1	1	1	1
Sodium Perborate	1	1	1	1	1	1	1		1	1		
Sodium Peroxide	1	1	1	1	1	1	1	1	1	1	1	1
Sodium Phosphate	1	1		1	1	1	1	1		1		1
Sodium Plumbite						1						
Sodium Polyphosphate		1		1	1		1		1	1	1	
Sodium Pyrophosphate						1	1		1	1	1	
Sodium Resinate		1				1						
Sodium Salicylate	1											
Sodium Salts		1		1	1				1			

**MATERIALS COMPATIBILITY CHART**

	A105, A182, F5, F9, F11, F22	A182, F316	13 CR	TYPE 316	Monel	Hastelloy	Teflon	Viton	Neoprene	Ethylene Propylene	Buna N	Flexible Graphite Packing
<b>1- Acceptable for Use</b>												
<b>0 - Not Acceptable for Use</b>												
<b>Chemical</b>												
Sodium Silicate	1	1	1	1	1	1	1	1	1	1	1	
Sodium Silicofluoride				1								
Sodium Sulfate	1	1	1	1	1	1	1	1	1	1	1	
Sodium Sulfide	0	1	1	1	1	1	1	1	1	1	1	
Sodium Sulfite	1	1	1	1	0	0	1	1	1	1	1	
Sodium Tetraborate		1		1			1		1	1	1	
Sodium Tetrakisphosphate					1				1			
Sodium Triphosphate		1		1	1		1	1	1	1	1	
Sodium-M-Phosphate		1		1	1		1		1	1	1	
Sodium-M-Silicate					1				1			
Sorbitol	0											
Soybean Oil	1	1	1	1	1	1	1	1	1	1	1	
Stanic Chloride	0	0	0	0	0	1	1	1	1	1	1	
Stannous Bisulfate					1							
Stannous Chloride	0	1		1								
Starch	1	1	1	1	1		1	1	1	1	1	
Steam	1	1	1	1	1		1		0	1	0	1
Steam Condensate	1	1	1	1	1	1	1	1	1		1	
Stearic Acid 100%	1	1		1	1	1	1	1	1	1	1	
Stoddard Solvent	1	1		1	1							
Styrene (dry)	1	1		1	1							1
Sugar Solution	0	1		1	1	1	1	1	1	1	1	
Sulfate Liquor		1	1	1	1			1				
Sulfate Oils					1							
Sulfite Liquor	0	1		1	0		1					1
Sulfur (molten)	0	1	1	1	1	1	1	0	0	0	1	
Sulfur Chloride	0	0		0	1	1	1	0	0	0		
Sulfur Dioxide (dry) 100%	1	1	1	1	1	0	1	1	1	0	1	
Sulfur Trioxide (dry) 100%	1	1		1	1	1	1	0	0	1		
Sulfuric Acid (spent)					1							
Sulfuric Acid 0%-10%	0	1	0	1	1	1	1	0	0	1		
Sulfuric Acid 10%-75%	0	1	0	1	1	1	1	0	0	1		
Sulfuric Acid 75%-90%	0	0	0	0	0	1	1	0	0			
Sulfuric Acid 90%-95%	1	1	0	1	0	1	1	0	0			
Sulfuric Acid 95%-100%		1	0	1	0	1	1	0	0	0		
Sulfurous Acid	0	1	0	1	0	1	1	1				1
Sulphonyl Chloride		0		0								
Talc Slurry					1			1				
Tall Oil	1	1		1	1	1	1					1
Tallow, Molten					1		1	1	1			
Tannic Acid	0	1		1	1	1	1	1	1	1	1	
Tannin					1		1	1	1			
Tanning Liquor												
Tar	1	1	1	1	1		1	1	0	0		1
Tar Acids					1							
Tartaric Acid	0	1		1	1	1	1	1	1			1
Tennox					1							
Terpene Monocyclic	1											
Tetrachloroethane		1		1								
Tetramine												
Tetraphosphoglucosate					1		1	1				
Tetraphosphoric Acid						1						
Thiamine Hydrochloride							1					

	A105, A182, F5, F9, F11, F22	A182, F316	13 CR	TYPE 316	Monel	Hastelloy	Teflon	Viton	Neoprene	Ethylene Propylene	Buna N	Flexible Graphite Packing
<b>Chemical</b>												
Thiophene					1							
Tin Plating Solution												
Titanium Tetrachloride	0				1	0						
Toluene or Toluol	1	1	1	1	1	1	1	1	0		0	1
Toluene Sulfanic Acid						1						
Tomato Juice		1		1	1	1						
Toxaphene						1						
Transmission Oil		1		1	1							
Tretolite					1							
Trichloroacetic Acid	0	0				1		1				
Trichlorobenzene									0			
Trichloroethylene	1	1	1	1	1	1	1	0	0	0	1	
Trichloromonofluoroethane		1		1								
Trichloropropane	1	1		1	1	1						
Trichlorotrifluoroethane		1		1								
Triethanolamine		1	1	1	1	1	1	1	1	1		
Triethylamine					1	1	1	1	1			
Triodium Phosphate		1		1								
Triphenylphosphite		1		1								
Tripotassium Phosphate		1		1		1		1	1	1		
Trisodium Phosphate		1	1	1	1			1				
Turpentine	1	1	1	1	1	1	1	0	0	0	1	
Uric Acid		1		1	1							
Varnish	1	1	1	1	1	1	1		0			1
Vegetable Oils	1	1		1	1	1	1	1			1	1
Vinegar	0	1		1	1	1	1	1		1	0	1
Vinyl Acetate	1	1		1	1	1	1					1
Vinyl Chloride	1	1	1	1	1	1						
Water - Fresh	1	1	1	1	1	1	1	1	1	1	1	1
Water - Sea	0	1	0	1	1	1	1	1				1
Wax (molten)	1	1		1	1			1				1
Whiskey and Wines	0	1	0	1	0	1	1	1	1	1	1	1
White Liquor	1	1	1	1								1
Xylene	1	1	1	1	1	1	1	1	0	0	0	1
Zeolite					1	1	1	1				1
Zinc Acetate	0	1		1	1	1	1	1	1	1		1
Zinc Ammonium Chloride							1	1	1	1		
Zinc Carbonate												
Zinc Chloride	0	1	0	1	1	1	1	1	1	1		1
Zinc Cyanide Solution		0										
Zinc Hydrosulfite		1		1			1	1	1	1	1	
Zinc Plating Solution												
Zinc Sulfate	0	1		1	1	1	1	1	1	1	1	1
Zinc Sulfate (acid)	0	1		1	1	1	1	1				

## API 602 Trim Number Versus Vogt Trim Description

API TRIM No.	API NOMINAL TRIM DESC.	TRIM DESC.	SERIES SUFFIX	TYPICAL IN VALVE SERIES	NOTES
1	13 Cr (No Hardfacing)	Trim: 13% Cr	None (Standard)	22461 22141	(1) Offer Trim 8.
2	304 (No Hardfacing)	None	None	None	(2) Offer 316/316L Trim
3	310 (No Hardfacing)	None	None	None	
4	Hard F6 (No Hardfacing)	None	None	None	Offer 1/2 or FHF
5 5A	Hardfaced (13 Cr Stem)	Trim 13% Cr Wedge/Seats: HF	FHF	12111FHF	(3) 5=Stellite 5A=NiCr Hardfacing
		Trim 13% Cr Disc/Seat: HF	FHF None (If Standard)	12141FHF 1510 (4) 2510	
6	F6 and CuNi (13 Cr and Monel Overlay)	None	None	None	(5) Offer MM Trim
7	F6 and Hard F6 (13 Cr Stem)	None	None	None	Offer FHF Trim
8 8A	F6 and Hardfaced	Trim 13% Cr Seat: HF	None	12111	(6) 1/2 HF
		Trim 13% Cr Seat: HF	None	12141	
		Trim 13% Cr Seat: HF	HF	10403HF	
9	Monel	Trim: Monel	MM	12111MM	
10	316	Trim: 316	None	12501 718	
11	Monel & Hardfaced (Monel Trim 1/2 HF)	Trim: Monel Seat: HF	MM	12141MM 701MM	
12	316 & Hardfaced (1/2 HF 316)	Trim: 316 Seat: HF	F8M	12111F8M 12401	
		Trim: 316 Seat: HF	F8M	12141F8M 12501F8M	
13	Alloy 20	None	None	None	
14	Alloy 20 & Hardfaced (1/2 HF Alloy)	None	None	None	
15	Hardfaced (304 FHF Trim)	None	None	None	(7)
16	Hardfaced (316 FHF Trim)	Trim: 316 Wedge/Seat: HF	F8H	12111F8H 12401FHF	
		Trim: 316 Disc/Seat: HF	FHF	12501FHF	
17	Hardfaced (347 FHF Trim)	None	None	None	
18	Hardfaced (Alloy 20 FHF)	None	None	None	

1) Other Vogt Valves with Cr trim and no HF seating meet the API 602 Trim 1 except for minimum hardness. API Trim 8 can be substituted for Trim 1 under API 602 Table 12 alternative trim rules.

2) API Trim 10 can be substituted for Trim 2 under API 602 Table 12 alternative trim rules.

3) Trim 5 requires Satellite (cobalt based) alloys. Trim 5A allows non-cobalt base hard facing alloys.

4) Many Vogt valves are supplied as standard with FHF trim but do not carry the FHF designator with the Series No. Typical of these as these Series 1510, 1610, 2510 and 2610. Most Class 1500 and higher F11 and F22 valves have FHF trims but are carried by the series designator.

5) API 602 Trim 8 can be substituted for Trim 6 under API 602 Table 12 alternative trim rules.

6) Most Vogt carbon and alloy steel gate and globe and 316/316L stainless steel gate valves have 1/2 HF seating surfaces. Such valves do not necessarily carry "HF" designator in their Series Suffix Number.

7) API Trim 16 can be substituted for Trim 15 under API 602 Table 12 alternative trim rules.

## Cross-Reference of ASTM Material Specifications

### Covering Cast and Forged Valves

MATERIAL	FORGINGS	CASTINGS	WROUGHT FITTINGS
Carbon Steel Cold Temperature Service	A105 A350-LF2	A216-WCB A352-LCC	A234-WPB A420-WPL6
Carbon-1/2 Moly Alloy Steel Cold Temperature Service	A182-F1	A217-WC1 A352-LC1	A234-WP1
3-1/2 Nickel Alloy Steel Low Temperature Service	A350-LF3	A352-LC3	A420-WPL3
1/2 Cr-1/2 Mo Alloy Steel 1/2 Cr-1/2 Mo-1 Ni Alloy Steel 3/4 Cr-1 Mo-3/4 Ni Alloy Steel 1 Cr-1/2 Mo Alloy Steel	A182-F2  A182-F12 CL2	 A217-WC4 A217-WC5	  A234-WP12 CL2
1-1/4 Cr-1/2 Mo Alloy Steel 2-1/4 Cr-1 Mo Alloy Steel 5 Cr-1/2 Mo Alloy Steel 5 Cr-1/2 Mo Alloy Steel 9 Cr-1 Mo Alloy Steel 13 Cr Alloy Steel	A182-F11 CL2 A182-F22 CL3 A182-F5 A182-F5a A182-F9 A182-F6	A217-WC6 A217-WC9  A217-C5 A217-C12 A743-CA15	A234-WP11 CL2 A234-WP22 CL3 A234-WP5  A234-WP9
Type 304 Stainless Steel (18 Cr-8 Ni) Standard Low Carbon High Temperature Service	A182-F304 A182-F304L A182-F304H	A351-CF8 A351-CF3 A351 CF10	A403-WP304 A403-WP304L A403-WP304H
Type 310 Stainless Steel (25 Cr-20 Ni) Type 316 Stainless Steel (16 Cr-12 Ni-2 Mo) Standard Low Carbon High Temperature Service	A182-F310H  A182-F316 A182-F316L A182-F316H	A351-CK20  A351-CF8M A351-CF3M A351-CF10M	A403-WP310  A403-WP316 A403-WP316L A403-WP316H
Type 317 Stainless Steel (18 Cr-13 Ni-3 Mo) Type 321 Stainless Steel (18 Cr-10 Ni-Ti) Standard High Temperature Service	A182 - F317  A182-F321 A182-F321H	A351 - CG8M	A403-WP317  A403-WP321 A403-WP321H
Type 347 Stainless Steel (18 Cr-10 Ni-Cb) Standard High Temperature Service	A182-F347 A182-F347H	A351-CF8C	A403-WP347 A403-WP347H
Type 348 Stainless Steel (18 Cr-10 Ni-Cb) Standard High Temperature Service	A182-F348 A182-F348H		A403-WP348 A403-WP348H

## Forging Materials

<p><b>ASTM A105 Carbon Steel (0.24 Carbon max.)</b> Where temperatures are moderate and corrosion resistance is not critical</p> <table border="0"> <tr> <td>C</td><td>0.18 - 0.24</td><td>TS Min. psi(Mpa): 70,000(485)</td></tr> <tr> <td>Mn</td><td>1.00 - 1.35</td><td>YS Min. psi(Mpa): 36,000(250)</td></tr> <tr> <td>Si</td><td>0.15 - 0.30</td><td>EL (2" Min.): 22%</td></tr> <tr> <td>P</td><td>0.030 Max.</td><td>RA Min.: 30%</td></tr> <tr> <td>S</td><td>0.015 - 0.040</td><td>Hardness, Bhn: Max. 187</td></tr> <tr> <td>Cr</td><td>0.20</td><td></td></tr> <tr> <td>Ni</td><td>0.20</td><td></td></tr> <tr> <td>Mo</td><td>0.06</td><td></td></tr> <tr> <td>V</td><td>0.02</td><td></td></tr> <tr> <td>Cb</td><td>0.02</td><td></td></tr> <tr> <td>Cu</td><td>0.20</td><td></td></tr> </table> <p>Total Residuals = 0.50</p>	C	0.18 - 0.24	TS Min. psi(Mpa): 70,000(485)	Mn	1.00 - 1.35	YS Min. psi(Mpa): 36,000(250)	Si	0.15 - 0.30	EL (2" Min.): 22%	P	0.030 Max.	RA Min.: 30%	S	0.015 - 0.040	Hardness, Bhn: Max. 187	Cr	0.20		Ni	0.20		Mo	0.06		V	0.02		Cb	0.02		Cu	0.20		<p><b>ASTM A182, Grade F9 - 9Cr - 1Mo</b> For services where the higher chrome alloys are preferred and where high temperature stability and oxidation resistance of the lower alloy steels are inadequate.</p> <table border="0"> <tr> <td>C</td><td>0.15 Max.</td><td>TS Min. psi(Mpa): 85,000(585)</td></tr> <tr> <td>Mn</td><td>0.30 - 0.60</td><td>YS Min. psi(Mpa): 55,000(380)</td></tr> <tr> <td>P</td><td>0.030 Max.</td><td>EL (2" Min.): 20%</td></tr> <tr> <td>S</td><td>0.030 Max.</td><td>RA Min.: 40%</td></tr> <tr> <td>Si</td><td>0.50 - 1.00</td><td>Hardness, Bhn: 179 - 217</td></tr> <tr> <td>Cr</td><td>8.00 - 10.00</td><td></td></tr> <tr> <td>Mo</td><td>0.90 - 1.10</td><td></td></tr> </table>	C	0.15 Max.	TS Min. psi(Mpa): 85,000(585)	Mn	0.30 - 0.60	YS Min. psi(Mpa): 55,000(380)	P	0.030 Max.	EL (2" Min.): 20%	S	0.030 Max.	RA Min.: 40%	Si	0.50 - 1.00	Hardness, Bhn: 179 - 217	Cr	8.00 - 10.00		Mo	0.90 - 1.10										
C	0.18 - 0.24	TS Min. psi(Mpa): 70,000(485)																																																														
Mn	1.00 - 1.35	YS Min. psi(Mpa): 36,000(250)																																																														
Si	0.15 - 0.30	EL (2" Min.): 22%																																																														
P	0.030 Max.	RA Min.: 30%																																																														
S	0.015 - 0.040	Hardness, Bhn: Max. 187																																																														
Cr	0.20																																																															
Ni	0.20																																																															
Mo	0.06																																																															
V	0.02																																																															
Cb	0.02																																																															
Cu	0.20																																																															
C	0.15 Max.	TS Min. psi(Mpa): 85,000(585)																																																														
Mn	0.30 - 0.60	YS Min. psi(Mpa): 55,000(380)																																																														
P	0.030 Max.	EL (2" Min.): 20%																																																														
S	0.030 Max.	RA Min.: 40%																																																														
Si	0.50 - 1.00	Hardness, Bhn: 179 - 217																																																														
Cr	8.00 - 10.00																																																															
Mo	0.90 - 1.10																																																															
<p><b>ASTM A350, LF2 (0.24 Carbon max.)</b> Where cold temperature (-50°F) impact strength is essential.</p> <table border="0"> <tr> <td>C</td><td>0.18 - 0.24</td><td>TS Min. psi(Mpa): 70,000(485)</td></tr> <tr> <td>Mn</td><td>1.00 - 1.35</td><td>YS Min. psi(Mpa): 36,000(250)</td></tr> <tr> <td>Si</td><td>0.15 - 0.30</td><td>EL (2" Min.): 22%</td></tr> <tr> <td>P</td><td>0.030 Max.</td><td>RA Min.: 30%</td></tr> <tr> <td>S</td><td>0.015 - 0.040</td><td>Hardness, Bhn: Max. 197</td></tr> <tr> <td>Cr</td><td>0.20</td><td>-50F Charpy: Min. Impact</td></tr> <tr> <td>Ni</td><td>0.20</td><td>Energy (Ft/Lb): (J)</td></tr> <tr> <td>Mo</td><td>0.06</td><td>Average of Each</td></tr> <tr> <td>V</td><td>0.02</td><td>Set of 3 Specimen: 15(20)</td></tr> <tr> <td>Cb</td><td>0.02</td><td>For One Specimen: 12(15)</td></tr> <tr> <td>Cu</td><td>0.20</td><td></td></tr> </table> <p>Total Residuals = 0.50</p>	C	0.18 - 0.24	TS Min. psi(Mpa): 70,000(485)	Mn	1.00 - 1.35	YS Min. psi(Mpa): 36,000(250)	Si	0.15 - 0.30	EL (2" Min.): 22%	P	0.030 Max.	RA Min.: 30%	S	0.015 - 0.040	Hardness, Bhn: Max. 197	Cr	0.20	-50F Charpy: Min. Impact	Ni	0.20	Energy (Ft/Lb): (J)	Mo	0.06	Average of Each	V	0.02	Set of 3 Specimen: 15(20)	Cb	0.02	For One Specimen: 12(15)	Cu	0.20		<p><b>ASTM A182, Grade F91 - 9Cr - 1Mo - V</b> For high temperature Boiler applications requiring high strength alloys.</p> <table border="0"> <tr> <td>C</td><td>0.08 - 0.12</td><td>TS Min. psi(Mpa): 85,000(585)</td></tr> <tr> <td>Mn</td><td>0.30 - 0.60</td><td>YS Min. psi(Mpa): 60,000(415)</td></tr> <tr> <td>P</td><td>0.020 Max.</td><td>EL (2" Min.): 20%</td></tr> <tr> <td>S</td><td>0.010 Max.</td><td>RA Min.: 40%</td></tr> <tr> <td>Si</td><td>0.20 - 0.50</td><td>Hardness, Bhn: Max 248</td></tr> <tr> <td>Cr</td><td>8.00 - 9.50</td><td></td></tr> <tr> <td>Mo</td><td>0.85 - 1.05</td><td></td></tr> <tr> <td>Cb</td><td>0.06 - 0.10</td><td></td></tr> <tr> <td>Ni</td><td>0.40 Max</td><td></td></tr> <tr> <td>V</td><td>0.18 - 0.25</td><td></td></tr> </table>	C	0.08 - 0.12	TS Min. psi(Mpa): 85,000(585)	Mn	0.30 - 0.60	YS Min. psi(Mpa): 60,000(415)	P	0.020 Max.	EL (2" Min.): 20%	S	0.010 Max.	RA Min.: 40%	Si	0.20 - 0.50	Hardness, Bhn: Max 248	Cr	8.00 - 9.50		Mo	0.85 - 1.05		Cb	0.06 - 0.10		Ni	0.40 Max		V	0.18 - 0.25	
C	0.18 - 0.24	TS Min. psi(Mpa): 70,000(485)																																																														
Mn	1.00 - 1.35	YS Min. psi(Mpa): 36,000(250)																																																														
Si	0.15 - 0.30	EL (2" Min.): 22%																																																														
P	0.030 Max.	RA Min.: 30%																																																														
S	0.015 - 0.040	Hardness, Bhn: Max. 197																																																														
Cr	0.20	-50F Charpy: Min. Impact																																																														
Ni	0.20	Energy (Ft/Lb): (J)																																																														
Mo	0.06	Average of Each																																																														
V	0.02	Set of 3 Specimen: 15(20)																																																														
Cb	0.02	For One Specimen: 12(15)																																																														
Cu	0.20																																																															
C	0.08 - 0.12	TS Min. psi(Mpa): 85,000(585)																																																														
Mn	0.30 - 0.60	YS Min. psi(Mpa): 60,000(415)																																																														
P	0.020 Max.	EL (2" Min.): 20%																																																														
S	0.010 Max.	RA Min.: 40%																																																														
Si	0.20 - 0.50	Hardness, Bhn: Max 248																																																														
Cr	8.00 - 9.50																																																															
Mo	0.85 - 1.05																																																															
Cb	0.06 - 0.10																																																															
Ni	0.40 Max																																																															
V	0.18 - 0.25																																																															
<p><b>ASTM A182, Grade F11, Class 2 (0.15 Carbon max.) 1-1/4Cr - 1/2Mo</b> To minimize graphitization encountered with carbon and carbon moly steels at high temperatures</p> <table border="0"> <tr> <td>C</td><td>0.10 - 0.15</td><td>TS Min. psi(Mpa): 70,000(485)</td></tr> <tr> <td>Mn</td><td>0.30 - 0.80</td><td>YS Min. psi(Mpa): 40,000(275)</td></tr> <tr> <td>P</td><td>0.040 Max.</td><td>EL (2" Min.): 20%</td></tr> <tr> <td>S</td><td>0.015 - 0.035</td><td>RA Min.: 30%</td></tr> <tr> <td>Si</td><td>0.50 - 1.00</td><td>Hardness, Bhn: 143 - 207</td></tr> <tr> <td>Cr</td><td>1.00 - 1.50</td><td></td></tr> <tr> <td>Mo</td><td>0.44 - 0.65</td><td></td></tr> </table>	C	0.10 - 0.15	TS Min. psi(Mpa): 70,000(485)	Mn	0.30 - 0.80	YS Min. psi(Mpa): 40,000(275)	P	0.040 Max.	EL (2" Min.): 20%	S	0.015 - 0.035	RA Min.: 30%	Si	0.50 - 1.00	Hardness, Bhn: 143 - 207	Cr	1.00 - 1.50		Mo	0.44 - 0.65		<p><b>ASTM A182, Grade F316 / F316L - 18Cr - 8Ni - 3Mo</b> For corrosion resistance applications where high temperature strength is required. Has restricted carbon level to minimize sensitization. Do not use for Service temperatures above 1000 °F.</p> <table border="0"> <tr> <td>C</td><td>0.030 Max.</td><td>TS Min. psi(Mpa): 75,000(515)</td></tr> <tr> <td>Mn</td><td>2.00 Max.</td><td>YS Min. psi(Mpa): 30,000(205)</td></tr> <tr> <td>P</td><td>0.040 Max.</td><td>EL (2" Min.): 30%</td></tr> <tr> <td>S</td><td>0.020 - 0.030</td><td>RA Min.: 30%</td></tr> <tr> <td>Si</td><td>1.00 Max.</td><td></td></tr> <tr> <td>Ni</td><td>10.00 - 14.00</td><td></td></tr> <tr> <td>Cr</td><td>16.00 - 18.00</td><td></td></tr> <tr> <td>Mo</td><td>2.00 - 3.00</td><td></td></tr> </table>	C	0.030 Max.	TS Min. psi(Mpa): 75,000(515)	Mn	2.00 Max.	YS Min. psi(Mpa): 30,000(205)	P	0.040 Max.	EL (2" Min.): 30%	S	0.020 - 0.030	RA Min.: 30%	Si	1.00 Max.		Ni	10.00 - 14.00		Cr	16.00 - 18.00		Mo	2.00 - 3.00																			
C	0.10 - 0.15	TS Min. psi(Mpa): 70,000(485)																																																														
Mn	0.30 - 0.80	YS Min. psi(Mpa): 40,000(275)																																																														
P	0.040 Max.	EL (2" Min.): 20%																																																														
S	0.015 - 0.035	RA Min.: 30%																																																														
Si	0.50 - 1.00	Hardness, Bhn: 143 - 207																																																														
Cr	1.00 - 1.50																																																															
Mo	0.44 - 0.65																																																															
C	0.030 Max.	TS Min. psi(Mpa): 75,000(515)																																																														
Mn	2.00 Max.	YS Min. psi(Mpa): 30,000(205)																																																														
P	0.040 Max.	EL (2" Min.): 30%																																																														
S	0.020 - 0.030	RA Min.: 30%																																																														
Si	1.00 Max.																																																															
Ni	10.00 - 14.00																																																															
Cr	16.00 - 18.00																																																															
Mo	2.00 - 3.00																																																															
<p><b>ASTM A182, Grade F22, Class 3 (0.15 Carbon max.) 2-1/4Cr - 1/2Mo</b> Where elevated temperature, surface stability and greater strength than F11 are needed</p> <table border="0"> <tr> <td>C</td><td>0.15 Max.</td><td>TS Min. psi(Mpa): 75,000(515)</td></tr> <tr> <td>Mn</td><td>0.30 - 0.60</td><td>YS Min. psi(Mpa): 40,000(275)</td></tr> <tr> <td>P</td><td>0.040 Max.</td><td>EL (2" Min.): 20%</td></tr> <tr> <td>S</td><td>0.015 - 0.035</td><td>RA Min.: 30%</td></tr> <tr> <td>Si</td><td>0.50 Max.</td><td>Hardness, Bhn: 156 - 207</td></tr> <tr> <td>Cr</td><td>2.00 - 2.50</td><td></td></tr> <tr> <td>Mo</td><td>0.87 - 1.13</td><td></td></tr> </table>	C	0.15 Max.	TS Min. psi(Mpa): 75,000(515)	Mn	0.30 - 0.60	YS Min. psi(Mpa): 40,000(275)	P	0.040 Max.	EL (2" Min.): 20%	S	0.015 - 0.035	RA Min.: 30%	Si	0.50 Max.	Hardness, Bhn: 156 - 207	Cr	2.00 - 2.50		Mo	0.87 - 1.13		<p><b>ASTM A182, Grade F316H - 18Cr - 8Ni - 3Mo</b> For corrosion resistance applications where extreme temperature strength is expected. Has restricted carbon range for high temperature strength above 1000 °F.</p> <table border="0"> <tr> <td>C</td><td>0.04 - 0.10</td><td>TS Min. psi(Mpa): 75,000(515)</td></tr> <tr> <td>Mn</td><td>2.00 Max.</td><td>YS Min. psi(Mpa): 30,000(205)</td></tr> <tr> <td>P</td><td>0.040 Max.</td><td>EL (2" Min.): 30%</td></tr> <tr> <td>S</td><td>0.020 - 0.030</td><td>RA Min.: 30%</td></tr> <tr> <td>Si</td><td>1.00 Max.</td><td></td></tr> <tr> <td>Ni</td><td>10.00 - 14.00</td><td></td></tr> <tr> <td>Cr</td><td>16.00 - 18.00</td><td></td></tr> <tr> <td>Mo</td><td>2.00 - 3.00</td><td></td></tr> </table>	C	0.04 - 0.10	TS Min. psi(Mpa): 75,000(515)	Mn	2.00 Max.	YS Min. psi(Mpa): 30,000(205)	P	0.040 Max.	EL (2" Min.): 30%	S	0.020 - 0.030	RA Min.: 30%	Si	1.00 Max.		Ni	10.00 - 14.00		Cr	16.00 - 18.00		Mo	2.00 - 3.00																			
C	0.15 Max.	TS Min. psi(Mpa): 75,000(515)																																																														
Mn	0.30 - 0.60	YS Min. psi(Mpa): 40,000(275)																																																														
P	0.040 Max.	EL (2" Min.): 20%																																																														
S	0.015 - 0.035	RA Min.: 30%																																																														
Si	0.50 Max.	Hardness, Bhn: 156 - 207																																																														
Cr	2.00 - 2.50																																																															
Mo	0.87 - 1.13																																																															
C	0.04 - 0.10	TS Min. psi(Mpa): 75,000(515)																																																														
Mn	2.00 Max.	YS Min. psi(Mpa): 30,000(205)																																																														
P	0.040 Max.	EL (2" Min.): 30%																																																														
S	0.020 - 0.030	RA Min.: 30%																																																														
Si	1.00 Max.																																																															
Ni	10.00 - 14.00																																																															
Cr	16.00 - 18.00																																																															
Mo	2.00 - 3.00																																																															
<p><b>ASTM A182, Grade F5 - 5Cr - 1/2Mo</b> With moderately corrosive fluids and in oil refineries where high temperature stability and oxidation resistance of the lower alloy steels are inadequate.</p> <table border="0"> <tr> <td>C</td><td>0.15 Max.</td><td>TS Min. psi(Mpa): 70,000(485)</td></tr> <tr> <td>Mn</td><td>0.30 - 0.60</td><td>YS Min. psi(Mpa): 40,000(275)</td></tr> <tr> <td>P</td><td>0.030 Max.</td><td>EL (2" Min.): 20%</td></tr> <tr> <td>S</td><td>0.015 - 0.035</td><td>RA Min.: 35%</td></tr> <tr> <td>Si</td><td>0.50 Max.</td><td>Hardness, Bhn: 143 - 217</td></tr> <tr> <td>Ni</td><td>0.50 Max.</td><td></td></tr> <tr> <td>Cr</td><td>4.00 - 6.00</td><td></td></tr> <tr> <td>Mo</td><td>0.44 - 0.65</td><td></td></tr> </table>	C	0.15 Max.	TS Min. psi(Mpa): 70,000(485)	Mn	0.30 - 0.60	YS Min. psi(Mpa): 40,000(275)	P	0.030 Max.	EL (2" Min.): 20%	S	0.015 - 0.035	RA Min.: 35%	Si	0.50 Max.	Hardness, Bhn: 143 - 217	Ni	0.50 Max.		Cr	4.00 - 6.00		Mo	0.44 - 0.65																																									
C	0.15 Max.	TS Min. psi(Mpa): 70,000(485)																																																														
Mn	0.30 - 0.60	YS Min. psi(Mpa): 40,000(275)																																																														
P	0.030 Max.	EL (2" Min.): 20%																																																														
S	0.015 - 0.035	RA Min.: 35%																																																														
Si	0.50 Max.	Hardness, Bhn: 143 - 217																																																														
Ni	0.50 Max.																																																															
Cr	4.00 - 6.00																																																															
Mo	0.44 - 0.65																																																															



## Valve Trim Materials

### Description and General Use

#### 13% Chromium

Stainless Steel  
Type 410

This stainless steel material lends itself to hardening by heat treatment and is excellent for contacting parts such as stems, gates and discs.

#### 13% Chromium

Stainless Steel  
Type 416

High-quality stainless steel yoke nut material having excellent anti-galling characteristics for better operating threads.

#### 18% Chromium

8% Nickel  
2% Molybdenum  
Stainless Steel  
Type 316  
Type 316L

Provides excellent resistance to corrosive media at high temperatures and toughness for service at low temperatures.

#### 18% Chromium

Stainless Steel  
Type 440 C

Used for hardened balls in ball check valves.

#### Nickel-Copper

Monel  
Alloy K500

This wrought material is precipitation hardened and possesses excellent corrosion resistance, high-strength properties and hardness for internal valve components.

#### Monel

Alloy 400

Non-hardened alloy, except by work hardened, that has high strength and toughness over a wide temperature range. Has excellent corrosion resistance in chlorine and alkyation service.

#### Alloy 20

Alloy 20 is corrosion resistant to hot sulfuric acids when compared to austenitic stainless steels such as such as 316 or 317.

### Description and General Use

#### Cobalt Base and Nickel Base

##### Hard-Facing Materials

Hard-facing materials, when used on seating surfaces of Gate, Globe and Check Valves, give extended service life and trouble-free operation.

#### Nickel-Moly-Chromium

Hastelloy C-276

A high-nickel alloy with exceptional resistance to corrosive attack by chlorine gas.

#### Precipitation-Hardened Stainless Steel

Grade 630 17-4 PH

Provides corrosion resistance and high strength for stems in NACE applications.

#### S-Monel

Grade M-25S

Material used for Monel castings.

#### ASTM A743, Grade CA-15

Material used for 13 CR castings. The cast equivalent to type 410 stainless steel.

#### Cast Cobalt

RCoCr-A

Material used for cobalt castings. The cast equivalent to Stellite #6.

#### Cast 316

Grade CF8M

Material used for 18-8 castings.

#### Inconel 625

Material is used for its high strength, excellent fabricability (including joining) and outstanding corrosion resistance.

#### Incoloy 825

Material is a nickel-iron-chromium alloy with additions of molybdenum, copper and titanium. The alloy's chemical composition is designed to provide exceptional resistance to many corrosive environments.

## Meeting the Demands of Today

### Asbestos-Free Valves

Asbestos-Free Packing  
Asbestos-Free Gasket

SAFE – EFFICIENT in retaining high and low temperature media.

### ADVANCED TECHNOLOGY PROVIDES:

- Environmental acceptance
- Elimination of media contamination
- Leak-proof integrity
- High thermal conductivity
- Self-lubricating operation
- Shrinkage resistance
- Corrosion-resistant inhibitor
- Less frequent maintenance
- Longer service life

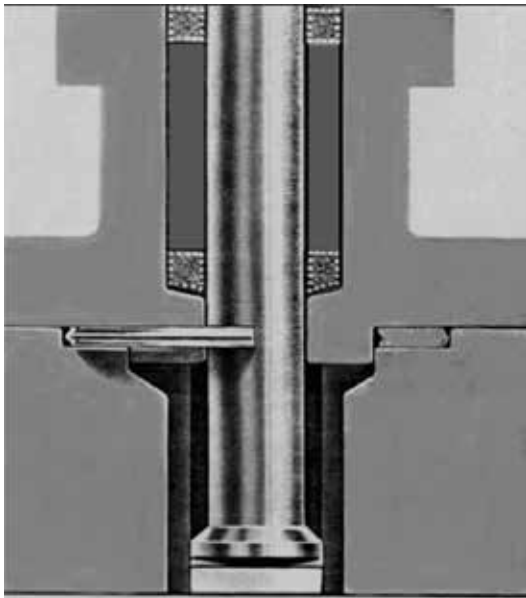

### STANDARD PACKING

Vogt standard valves are packed with one of the following asbestos-free packing sets:

### FLEXIBLE GRAPHITE PACKING

A 95% by weight minimum carbon packing set that consists of a cylindrical ring of flexible graphite packing supported on the top and bottom and braided graphite filament packing rings. The packing dispersed and embedded active corrosion inhibitor to protect against stem pitting. It may be used in fluids having a pH range of 0-14. The packing has minimal residues as follows:

Leachable Chlorides: 100PPM maximum  
Total Chlorides: 500PPM Maximum  
Total Sulfur: 1000PPM Maximum  
PTFE: None

### MOLDED TFE TEFLON-SHAPED PACKING

Vogt valves that have a series number suffixed with the letter "T" are packed with a molded, shaped TFE packing. This virgin TFE material needs no corrosion inhibitor in its composition, and its self-energizing shape ensures superior service and low gland bolting loads in high pressure liquid and dry gas applications. It may also be used in fluids having a pH range of 0-14. Temperature range: -120°F to 500°F (-84° to 260°C).

Since this packing has directional sealing, it can be reoriented for valves used in vacuum and/or combination vacuum/pressure service.

### OTHER PACKING

Other packing sets can be placed in Vogt valves at the user's option.

## Glossary of Abbreviations and Terms Used in the Valve Industry

**AARRH** - Arithmetic Average Roughness Height  
**AISI** - American Iron and Steel Institute  
**API** - American Petroleum Institute  
**ANSI** - American National Standards Institute, Inc.  
**ASME** - American Society of Mechanical Engineers  
**ASTM** - American Society for Testing and Materials  
**AWS** - American Welding Society

**BB** - Bolted Bonnet  
**BHN** - Brinell Hardness Number  
**Blind Flange** - A flange with no flow way bore, used to provide a pressure-tight closure of a flanged opening.  
**Btu** - British Thermal Unit  
**BWE** - Butt Weld Ends

**C or Cel** - Celsius Degrees  
**CI** - Cast Iron  
**CI** - Chlorine Institute  
**CR 13** - 13% Chromium Stainless Steel  
**CRES** - Corrosion Resistant Steel  
**Cv** - The number of U.S. gallons per minute of water at 700°F that will flow through a valve at a pressure drop of one psi.  
**CWP** - Cold Working Pressure

**DN** - Diameter Nominal (Metric)

**ELL** - Elbow

**FAS** - Free Alongside Steamer  
**F or Fahr** - Fahrenheit Degrees  
**F & D** - Faced and Drilled  
**FF** - Flat Face  
**FHF** - Full Hard Faced  
**FLG** - Flanged  
**FOB** - Free On Board  
**FTTG** - Fitting

**G** - Gas  
**gpm** - Gallons per Minute

**HF** - Hard Faced  
**HW** - Handwheel

**IBBM** - Iron Body Bronze Mounted  
**ID** - Inside Diameter  
**INT** - Integral  
**IPS** - Iron Pipe Size  
**ISRS** - Inside Screw Rising Stem  
**ISNRS** - Inside Screw Non. Rising Stem

**Kg** - Kilograms  
**Km** - Kilometers

**LH** - Left Hand

**MAV** - Motor Actuated Valve  
**mm** - Millimeter  
**MOV** - See MAV  
**MSS** - Manufacturers Standardization Society of the Valve & Fitting Industry

**NACE** - National Association of Corrosion Engineers  
**NPS** - National Pipe Size  
**NPT** - National Standard Pipe Thread Taper  
**NRS** - Non Rising Stem

**OD** - Outside Diameter  
**One-Piece-Stem** - An inseparable Stem and Disc made from one piece of metal.

**OS&Y** - Outside Screw and Yoke  
**OWG** - Oil, Water & Gas (See CWP)

**PN** - Pressure Nominal (Metric)  
**Psi** - Pounds per square Inch  
**Psia** - Pounds per square Inch absolute  
**Psig** - Pounds per square Inch gage  
**P/T** - Pressure - Temperature

**Rc** - Rockwell "C" Hardness  
**RF** - Raised Face  
**RH** - Right Hand  
**RMS** - Root Mean Square Roughness Height  
**RS** - Rising Stem  
**RTJ** - Ring-Type Joint

**S** - Steam  
**SAE** - Society of Automotive Engineers  
**SC** - Swing Check Valve  
**Sch. Or Sched.** - Schedule (Pipe Wall Thickness)  
**SCFM** - Standard Cubic Feet per Minute  
**Screw Bonnet** - Body and Bonnet threaded together  
**SE** - Screwed Ends  
**Seal Weld** - Threaded Joint Back Welded for Seal  
**SS** - Stainless Steel  
**Stem Nut** - Operating Nut  
**Stuffing Box** - Packing Chamber  
**STD** - Standard Wall Thickness  
**Stop Check** - A Check Valve in which the closure member can be mechanically closed.  
**SWE** - Socket Weld End  
**SWP** - Steam Working Pressure

**T** - Tee  
**Thd.** - Threaded  
**TIR** - Total Indicator Reading

**UB** - Union Bonnet

**W** - Water  
**Wedge** - Gate  
**WOG** - Water, Oil and Gas (See CWP)  
**WSP** - Working Steam Pressure  
**WWP** - Working Water Pressure

**XS** - Extra Strong Wall Thickness  
**XXS** - Double Extra Strong Wall Thickness

**Y** - Wye Valve, Fitting or Strainer  
**Yoke Bushing** - Operating Stem Nut  
**Yoke Nut** - Stem Nut

Refer to MSS-SP-96 for additional Abbreviations and Terms used in the Valve and Fitting Industry. (Manufacturers Standardization Society, 127 Park Street N.E., Vienna, VA 22180)

## Standards in the Valve Industry

Codes and standards play an important role in the design and production of forged steel valves, fittings and unions. These Codes and standards cover material, product dimensions, design, examination, inspection, testing procedure, pressure/temperature ratings and safety.

Material standards are developed by such organizations as the American Society for Testing and Materials (ASTM), the American Iron and Steel Institute (AISI), the Society of Automotive Engineers (SAE) and the National Association of Corrosion Engineers (NACE).

The American National Standards Institute, Inc. (ANSI) has a membership comprised of both user and producer groups and serves as the national coordinator for the majority of code and product standards related to the Valve and Fittings Industry. Product standards are also developed and issued by individual user and/or manufacturing agencies such as the American Society of Mechanical Engineers (ASME), American Petroleum Institute (API) and the Manufacturers' Standardization Society (MSS).

Procedural and Safety standards are issued by ANSI, MSS and ASME.

Following is a partial list of the codes and standards that have a direct bearing on the design and production of Vogt's forged steel valves, fittings and unions. The codes and standards are interrelated as the following descriptions project:

### ASME Boiler & Pressure Vessel Code

- Section I – Power Boilers
- Section II – Material Specifications
- Section III – Nuclear Power Plant Components
- Section V – Non-destructive Examination
- Section VIII – Pressure Vessels
- Section IX – Welding and Brazing Qualifications

The previous codes (Sections I, III and VIII) cover construction requirements for Boilers, Pressure Vessels and Nuclear Components that require Authorized Inspection Agency involvement. Section I and VIII codes relate to the Boiler and Pressure Vessel proper and not to external piping. Section III code includes rules for nuclear components including piping. Section II, V and IX codes cover material, non-destructive examination and welding requirements, respectively, for ASME construction.

### ASME Codes for Pressure Piping

- B31.1 – Power Piping
- B31.2 – Fuel Gas Piping
- B31.3 – Process Piping
- B31.4 - Pipeline Transportation Systems for Liquid Hydrocarbon and Other Liquids
- B31.5 - Refrigeration Piping and Heat Transfer Components
- B31.8 - Gas Transmission and Distribution Piping Systems
- B31.9 - Building Services Piping Systems
- B31.11 - Slurry Transportation Piping Systems

The above are piping construction codes that include requirements for design, materials, fabrication, examination, testing, inspection and components. Valve, fitting, and flange requirements used in these piping systems are normally referenced standards, as follows:

### Inspection and Testing

- MSS-SP-61 - Pressure Testing of Steel Valves
- API-598 - Valve Inspection and Testing

The above highly recognized standards provide detailed instructions for the inspection and testing of valves.

### Valve Standards

- ASME B16.34 - Valves Flanged, Threaded and Welding End
- API-600 / ISO 10434 – Bolted Bonnet Steel Gate Valves for Petroleum and Natural Gas Industries
- API-602 / ISO 15761 – Steel Gate, Globe and Check Valves for Sizes DN 100 and Smaller for the Petroleum and Natural Gas Industries

- MSS-SP-99 - Instrument Valves
- MSS-SP-105 - Instrument Valves for Code Applications
- MSS-SP-134 - Valves for Cryogenic Service Including Requirements for Body/Bonnet Extensions

The above are component (valve) standards used for construction of Vogt valves as noted in this catalog

## Standards in the Valve Industry

### Valve and Flange Details

ASME B16.5 - Pipe Flanges and Flanged Fittings

ASME B16.11 - Forged Fittings, Socket-Welding and Threaded

ASME B1.20.1 - Pipe Threads, General Purpose, Inch

ASME B16.10 - Face to Face and End to End Dimensions of Valves

ASME B16.20 - Metallic Gaskets for Pipe Flanges: Ring Joint, Spiral Wound, and Jacketed

ASME B16.25 - Buttwelding Ends

MSS-SP-6 - Standard Finishes for Contact Faces of Pipe Flanges and Connecting-End Flanges of Valves and Fittings

MSS-SP-25 - Standard Marking Systems for Valves, Fittings, Flanges and Unions

MSS-SP-45 - Bypass and Drain Connections

The above standards are detailed dimensional, marking, finish and bypass valve and fitting instructions for use in the manufacture of valves, flanges and fittings. The product standards normally refer to these standards for detailed instructions.

### NACE Standard

MR0175 / ISO 15156-1 Petroleum and Natural Gas Industries- Materials for use in H<sub>2</sub>S-containing Environments in Oil and Gas Production.

This standard is a recognized practice for selection of materials for construction of valves to be used in a sour environment. Such materials are recommended when Stress Corrosion Cracking (SCC) and/or Sulfide Stress Cracking (SSC) is anticipated.

MR0103 Materials Resistant to Sulfide Stress Cracking in Corrosive Petroleum Refining Environments.

This standard is a recognized practice for selection of materials for construction of valves to be used in a sour environment. Such materials are recommended when Sulfide Stress Cracking (SSC) is anticipated.

### Chlorine Institute

Pamphlet # 6 – Piping Systems for Dry Chlorine

This publication is intended to provide useful information concerning the construction of Chlorine piping systems including valves.

For detailed Material Standards used by Vogt valves, see pages 126 and 127

Addresses:

American Iron & Steel Institute (AISI)  
1140 Connecticut Ave., NW  
Suite 705  
Washington, DC 20036

American National Standards Institute (ANSI)  
1819 L Street, NW  
6th floor  
Washington, DC 20036

American Petroleum Institute (API)  
1220 L Street, NW  
Washington, DC 20005-4070

American Society of Mechanical Engineers (ASME)  
ASME International  
Three Park Avenue  
New York, NY 10016-5990

American Society of Testing and Materials  
100 Barr Harbor Drive  
West Conshohocken, PA 19428-2959

Manufacturers Standardization Society of the Valve & Fitting Industry  
127 Park Street, N.E.  
Vienna, VA 22180-4602

NACE International  
1440 South Creek Drive  
Houston, TX 77084-4906

Society of Automotive Engineers (SAE)  
400 Commonwealth Drive  
Warrendale, PA 15096-0001

The Chlorine Institute, Inc.  
1300 Wilson Blvd.  
Arlington, VA 22209

# Replacement Parts

## REPLACEMENT PARTS FOR VOGT VALVES

Vogt valves are carefully made from selected materials to give long, trouble-free service when properly installed in applications for which they were designed. Proper care and maintenance in the field can contribute significantly to maximum performance. Much of the field maintenance is of a routine nature and can be readily performed by the user. However, major repairs are discouraged and it is recommended that valves be returned to the factory for inspection and rework when major repairs are indicated.

The following information is offered as an aid to field maintenance of Vogt valves. However, Vogt valves repaired in the field do NOT carry the "Product Warranty" of valves repaired in our own facilities.

### PRELIMINARY CONSIDERATIONS

1. Use experienced, trained personnel.
2. Observe all standard safety precautions.
3. If possible, remove the valve from the line so that work can be done in a clean, well-lit area.
4. Use genuine Vogt replacement parts.
5. Use proper tools.
6. Pressure-test the valve before reinstalling. This is particularly essential on valves intended for critical service.
7. Remember that improper repairs can be hazardous.

### REPLACEMENT PARTS – HOW TO ORDER

Genuine replacement parts are available for Vogt current standard valves and can usually be shipped from stock. All parts are made to gauge with the same careful inspection and laboratory control given original valves.

Orders for replacement parts should clearly identify the items required and should specify the correct name of the part, valve size, series number, drawing number, revision number and material, etc. This information is shown on the identification disc that is attached to the hand-wheel. The date of purchase and/or the order number will further identify the parts, especially those for special valves.

(See page 133 for Gasket and Packing Sets and page 134 for Bonnet assemblies)

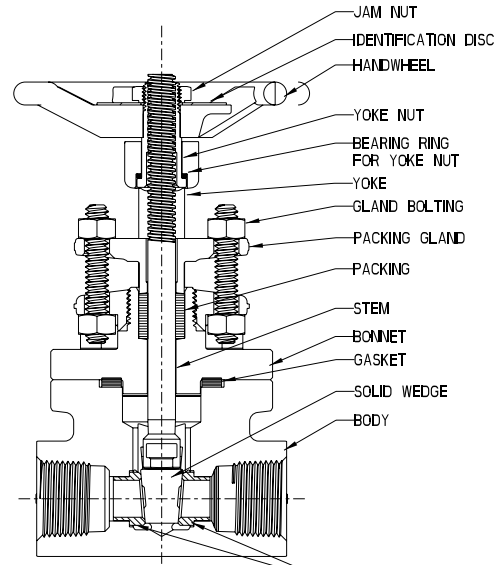

**GATE VALVE**

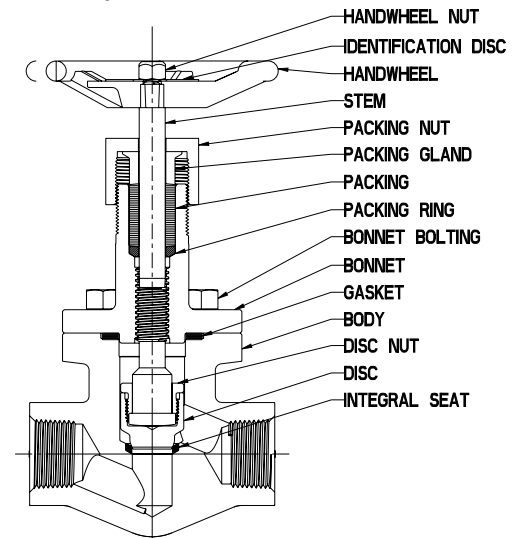

**GLOBE VALVE**

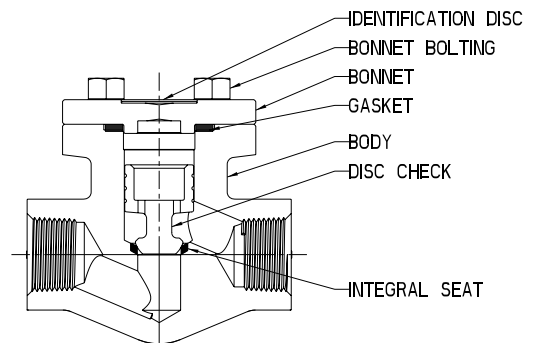

**CHECK VALVE**

## Packing and Gaskets

A high degree of standardization of Vogt Valves Vogt valves permits a small stock of replacement packing and gaskets to service your Vogt valves. The following matrix and part number tables provide the details for the purchasing of replacement gaskets for your Vogt bolted bonnet valves and packing for our popular class 150, 300, 600, 800, 1500, 1690 and 2680 gate, globe and angle valves.\*

Packing Matrix

PRESSURE CLASS	NPS DN	½ 15	¾ 20	1 25	1¼ 32	1½ 40	2 50	2½ 65	3 80	4 100
150 Conventional Port		B	B	C	D	D	E	F	F	G
300 Conventional Port		B	B	C	D	D	E	F	F	G
600 Conventional Port		B	B	C	D	D	E	F	F	G
800 Conventional Port		B*	B	C	D	D	E	F	F	-
1500 Conventional Port		J	J	D	E	E	F	-	-	-
600 and 800 Full Port		B	C	D	-	E	F	-	-	-
1500 Full Port		B	D	E	E	F	-	-	-	-
Class 800 LTD Class		C	C	D	-	F	F	-	-	-
Class 1690 LTD Class		C	C	E	-	G	G	-	-	-
Class 2680 LTD (Globe)		C	E	E	-	G	G	-	-	-
Class 2680 LTD Class (Gate)		C	E	E	-	H	H	-	-	-

Gasket Matrix (Spiral-wound Type)

PRESSURE CLASS	NPS DN	½ 15	¾ 20	1 25	1¼ 32	1½ 40	2 50	2½ 65	3 80	4 100
150 Conventional Port		A	A	B	C	C	D	E	E	F
300 Conventional Port		A	A	B	C	C	D	E	E	F
600 Conventional Port		A	A	B	C	C	D	E	E	F
800 Conventional Port		A*	A	B	C	C	D	E	F	-
1500 Conventional Port		A	A	B	C	C	D	-	-	-
600 and 800 Full Port		A	B	G	-	D	E	-	-	-
1500 Full Port		A	B	C	C	D	-	-	-	-

Packing Set Part Numbers

MATRIX	FLEXIBLE GRAPHITE		FLUOROPOLYMER
	PACKING SET PN**	PACKING CARTRIDGE PN***	PACKING SET PN**
B	55163	55175	55276
C	55166	55176	55286
D	55167	55177	55287
E	55169	55178	55288
F	55170	-	55289
G	55171	-	55285
J	55165	55179	55294
H	55173	-	-

\* API 602/ASME B16.34 type valves—see valve description. For other valves, consult your Vogt Valves distributor.

\*\* Order packing by Packing Set PN. Individual rings of complete set will be supplied.

\*\*\* One-piece or two-piece Packing Cartridge will be supplied when this PN is used.

Gasket Usage Table

GASKET	WHERE USED
304/Graphite	A105, A182-F5, F9, F11 Cl 2, F22 C I3 Valves
316/Graphite	A182, F316 Valves
316/fluoropolymer	"T" Suffix Trimmed Valves
Monel/Graphite	MM & HF Acid Trimmed Valves
Monel/fluoropolymer	Chlorine Valves

Gasket Part Numbers

GASKET MATRIX	PART NUMBER	SPIRAL-WOUND GASKET DESCRIPTION
A	55002	304/Graphite-filled
	55003	316/Graphite-filled
	55004	316/fluoropolymer-filled
	55005	Monel/Graphite-filled
	55006	Monel/fluoropolymer-filled
B	55007	304/Graphite-filled
	55008	316/Graphite-filled
	55009	316/fluoropolymer-filled
	55010	Monel/Graphite-filled
	55011	Monel/fluoropolymer-filled
C	55025	304/Graphite-filled
	55026	316/Graphite-filled
	55027	316/fluoropolymer-filled
	55028	Monel/Graphite-filled
	55029	Monel/fluoropolymer-filled
D	55017	304/Graphite-filled
	55018	316/Graphite-filled
	55019	316/fluoropolymer-filled
	55020	Monel/Graphite-filled
	55021	Monel/fluoropolymer-filled
E	55030	304/Graphite-filled
	55031	316/Graphite-filled
	55032	316/fluoropolymer-filled
	55033	Monel/Graphite-filled
	55034	Monel/fluoropolymer
F	55042	304/Graphite-filled
	55043	316/Graphite-filled
	55044	316/fluoropolymer-filled
	55045	Monel/Graphite-filled
	-	Monel/fluoropolymer
G	55012	304/Graphite-filled
	55013	316/Graphite-filled
	55014	316/fluoropolymer-filled
	55015	Monel/Graphite-filled
	55016	Monel/fluoropolymer



## Class 800 Gate Valve Conventional Port Bonnet Replacement Assemblies

Emission Reduction  
Standard

Some valve end users find it more expedient to replace the bonnet subassembly, complete with new packing, when repacking small bore valves. To support this maintenance philosophy, Vogt valve users may purchase A105 bonnet subassemblies for replacement on their Vogt valves by specifying the parts numbers noted below. The removed bonnet assemblies, if not damaged and are serviceable, can be repacked in a valve repair shop environment and be used during a later valve repacking cycle.

- Repacking made easy
- Promotes quick change
- Completely packed and ready to install
- Supports valve repacking in valve shop environment
- High degree of standardization permits retrofitting of popular Vogt Class 150, 300, 600 and 800, 13 Cr trimmed, bolted bonnet valves

The Replacement Bonnet Assembly Packages can be easily installed on most existing in-line Compact Design Gate Valves in Classes 150, 300, 600 and 800, of A105 bolted bonnet design with 13 Cr. trim. Specify the desired replacement Bonnet Assembly Package for the valve size and series you intend to repack by replacing the bonnet subassembly.

SIZE	EMISSION REDUCTION RETROFIT BONNET ASSEMBLY PACKAGE	STANDARD RETROFIT BONNET ASSEMBLY PACKAGE	E	
			IN	MM
1/2 3/4	41000-04	21000-04	4.00	102
1	41000-06	21000-06	4.75	121
1-1/4 1-1/2	41000-08	21000-08	5.75	146
2	41000-09	21000-09	7.00	178

Write for Vogt's installation procedure covering instructions for proper field replacement of these bonnet subassemblies.

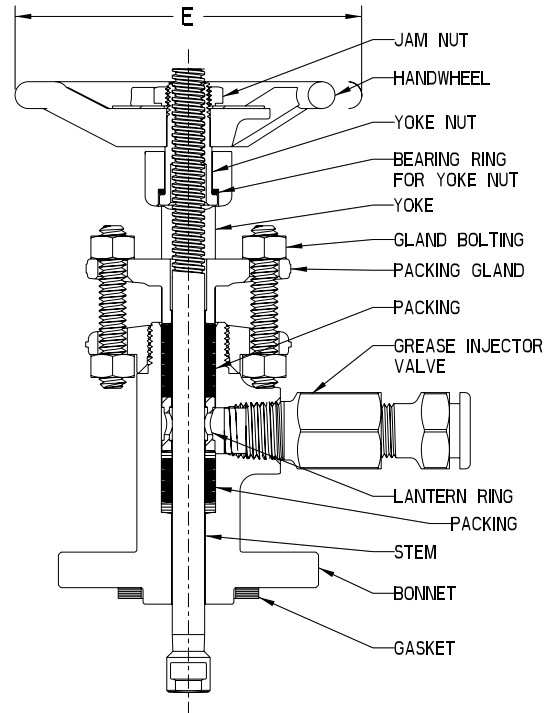

**SERIES 41000**  
**EMISSION REDUCTION**  
**A105/13% CR. TRIM**

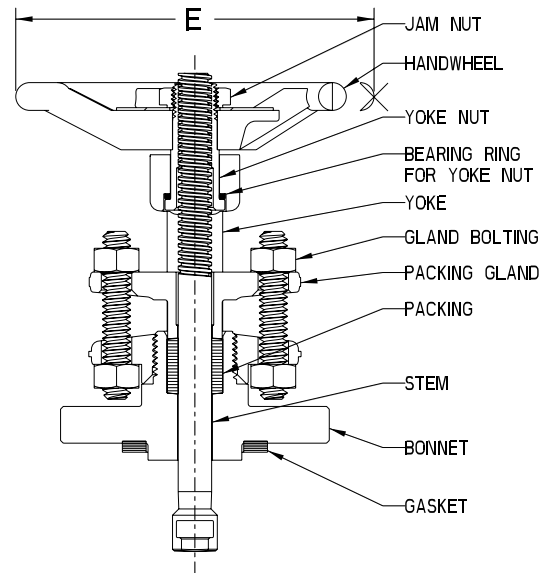

**SERIES 21000**  
**STANDARD**  
**A105/13% CR. TRIM**

## Torque Requirements

MAX HANDWHEEL CLOSING TORQUE FT-LB										
SIZE	CLASS 800 GATE	CLASS 800 FULL PORT GATE	CLASS 1500 GATE	CLASS 1500 FULL PORT GATE	CLASS 2500 FULL PORT GATE	CLASS 800 GLOBE	CLASS 800 FULL PORT GLOBE	CLASS 1500 GLOBE	CLASS 1690 GLOBE	CLASS 2680 FULL PORT GLOBE
½"	15	15	25	25	30	15	15	25	25	30
¾"	15	20	25	35	75	15	30	25	25	75
1"	20	40	35	55	75	30	40	35	40	75
1¼"	50	50	75	75				60		
1½"	50	70	75	115	175	40	75	60	125	175
2"	70	100	115	N/A	175	75	100	100	125	175

RECOMMENDED MAXIMUM BONNET BOLT TORQUES (DRY, UN-LUBRICATED VALUES)								
		½	¾	1	1 ¼	1 ½	2	3
CLASS 800	QTY - BOLT DIAMETER	4 - 3/8"	4 - 3/8"	4 - 7/16"	4 - 5/8"	4 - 5/8"	4 - 5/8"	8 - 3/4"
	TORQUE - B7 (ft-lb)	35	35	45	125	125	125	175
	TORQUE - B16 (ft-lb)	35	35	45	125	125	125	175
	TORQUE - B8M (ft-lb)	35	35	45	115	115	115	156
CLASS 1500	QTY - BOLT DIAMETER	4 - 1/2"	4 - 1/2"	4 - 9/16"	8 - 9/16"	8 - 9/16"	8 - 5/8"	
	TORQUE - B7 (ft-lb)	85	85	100	100	100	125	
	TORQUE - B16 (ft-lb)	85	85	100	100	100	125	
	TORQUE - B8M (ft-lb)	75	75	100	100	100	115	

**REDUCE ABOVE VALUES BY 25% TO 30% IF ANY TYPE OF LUBRICATION IS USED ON BOLTING**

MAXIMUM PACKING GLAND BOLTING TORQUE				
SIZE	CLASS 150, 300, 600 & 800 CONV. PORT	CLASS 300, 600 & 800 FULL PORT	CLASS 1500	CLASS 1500 FULL PORT
½"	1.8 ft-lb	1.8 ft-lb	4.2 ft-lb	4.2 ft-lb
¾"	1.8 ft-lb	3.7 ft-lb	4.2 ft-lb	7.5 ft-lb
1"	3.7 ft-lb	4.0 ft-lb	7.5 ft-lb	13.9 ft-lb
1¼"	4.0 ft-lb		13.9 ft-lb	13.9 ft-lb
1½"	4.0 ft-lb	7.5 ft-lb	13.9 ft-lb	15.9 ft-lb
2"	7.5 ft-lb	8.5 ft-lb	15.9 ft-lb	
2½"	8.5 ft-lb			
3"	8.5 ft-lb			
4"	12.0 ft-lb			

## ***Care and Maintenance of Vogt Forged Steel Valves***

### ***Valve Care Before Installation***

Vogt valves are carefully made from selected materials to give long, trouble-free service when properly installed in applications for which they were designed. Proper care and maintenance in the field can contribute significantly to maximum performance.

The care the valve receives between the time it is shipped by the manufacturer and installed in the piping system is important. During this period, the valve can be handled many times and can be kept in storage for long periods. Industrial valves are not delicate, but they are mechanical devices that should be treated as such and handled with care.

Vogt always provides valves with appropriate end covers to protect the end connections and to prevent foreign material from entering the valve. In addition, small valves are shipped in sealed cartons while larger valves are usually palletized. If at all practical, keep the valves in the cartons or on pallets with the end covers in place until ready to be installed. Storing the valves off the ground and indoors is always preferable. When stored outside, valves should be off the ground and protected by a weatherproof cover.

Prior to installation, the valves and nameplates should be checked for proper identification to be sure the valve is the proper type and of suitable pressure class. Actuate the valve to check for possible damage from shipping and handling. Also, it is extremely important to inspect the interior of both the valve and the adjoining pipe for cleanliness. By far, the major cause of seat leakage and seat damage is foreign material in the line. Also, inspect the end connections to be sure that pipe threads and flange faces are free of scratches, nicks or dents.

### ***Routine Inspection and Maintenance***

Once the right valve is properly installed, field maintenance is of a generally routine nature and can be readily performed by the user. The critical areas of the valve include the stem threads and those locations where leakage will most likely occur – the stem packing, the bonnet joint, the seat and the end connections. It is desirable that a maintenance program be established that will include periodic inspection of the noted critical areas. Stem threads should be lubricated prior to installation and periodically as part of the regular inspection. A high pressure and temperature lubricant such as Dow Corning Molykote™ G-n paste should be used.

The most common location of a noticeable leak is at the stem seal. Leakage at the stem can usually be stopped by adjusting the packing. If leakage cannot be stopped by packing adjustment, repacking is indicated. However, back-seating the valve and attempting to repack under pressure is hazardous and is not recommended. Rather than attempting to repack under pressure, it is preferable to use the backseat to control stem leakage until a shutdown provides safe repacking conditions.

### ***Major Field Repair***

Maintenance involving rework or replacement parts is considered major repair. When circumstances dictate field repair of Vogt valves, the following information is offered as an aid. It must be pointed out, however, that the Vogt valves repaired in the field are no longer under “Product Warranty,” and in no event is Vogt liable for any cause whatsoever. There are no warranties of any kind whatsoever, expressed or implied, other than those stated in Vogt’s current Terms and Conditions.

#### **Preliminary Considerations for Valve Repair:**

1. Use experienced, trained personnel.
2. Observe all standard safety precautions.
3. If possible, remove the valve from the line so that work can be done in a clean, well-lit area.
4. Use genuine Vogt replacement parts.
5. Use proper tools.
6. Pressure test the valve before reinstalling. This is particularly essential on valves intended for critical service.
7. Remember that improper repairs can be hazardous.

## Care and Maintenance of Vogt Forged Steel Valves

### Replacement Parts ... How to Order

Genuine replacement parts are available for Vogt current standard valves and can usually be shipped from stock. All parts are made to gauge with the same careful inspection and laboratory control given original valves.

Orders for replacement parts should clearly identify the items required and should specify the correct name of the part, valve size, series number, drawing number, revision number and material, etc. This information is shown on the identification disc that is attached to the hand-wheel. The date of purchase and/or the order number will further identify the parts, especially those for special valves.

The embossed number on each hand-wheel, having a prefix letter "V", is the pattern number of the hand-wheel and has no relation to the ordering of other valve parts. Prices for valve parts will be furnished on application.

### Tools For Installing Replacement Parts

Wrenches are available (price on application) for the removal and replacement of renewable seats for globe, angle and check valves. The wrenches are machined to an accurate finish to fit the drive notches or lugs of the seat and are properly heat treated for strength and toughness.

### Disassembly

Small valves of the union bonnet type or of the new screw bonnet type are readily disassembled by unscrewing the union nut or the bonnet. In bolted bonnet valves, the nut should be removed from the bonnet stud bolts or hexagon head cap screws removed from the body. Tight bolt threads may be loosened by applying penetrating oil to the threads or by selectively heating the bolt at the point of the thread engagement. On bonnet joints of the through bolt type, the bolts may be cut between the body and bonnet flanges for removal.

### Stems

Tight stems in valves of the O.S. & Y. type are caused by either dry, worn packing or non-lubrication of the yoke nut threads. Applying a few drops of oil to the stem threads and packing and opening and closing the valve a few times, may loosen the stem. At the same time, make sure the packing gland bolting is pulled down evenly so the gland will not bind against the stem. However, care should be taken not to over-compress the packing.

A tight stem in an inside screw valve may also result from worn or over-compressed packing, or the stem bonnet threads may "freeze" from excessive service temperatures or from corrosive fluids in the valve. If the stem turns freely after all packing is removed and if the surface of the stem in contact with the packing is in good condition, a new packing is the remedy. If the stem is still tight, turn the valve to the upright position, fill the stuffing box with penetrating oil and let soak. If the stem remains tight, a new bonnet and stem are required or, if practical, an O.S. & Y type valve could be substituted.

### Bonnet Joints

On valves of the union bonnet type, repairs can be made without removing the valve from the line, provided there is enough wrench room for loosening and tightening the bonnet nut. Before loosening the bonnet nut, be sure the valve has been relieved of all pressure. A few hammer taps to the side of the bonnet nut or around the body neck on screw bonnet type valves will loosen the nut or bonnet. Gasket joints require a smooth, clean surface on both the body and the bonnet gasket faces and a new gasket is recommended for reassembly. On bolted bonnet valves in high-temperature service and particularly where severe thermal cycling is involved, it is recommended that bolt torque be checked periodically. This recommendation applies to gland bolting as well.

### Packing

Vogt valves have well-proportioned stuffing boxes filled with the best grade packing material available. Before repacking, be sure to have the right grade, type and size of packing.

**Repacking under pressure is hazardous and is not recommended.** The backseat should be used as a temporary measure to control stem leakage until a shutdown provides safe repacking conditions.

Wipe all parts of the stuffing box, inside and out, before installing the new packing. Vogt uses a split ring type packing. If this type is used for replacement, take care to stagger the ring slits so that they are not in-line. After putting in a few rings, tamp them into place well, using the packing gland as a tamping tool. Then add enough packing to fill the stuffing box. Pressure on the packing is applied by the packing nut or gland flange bolting, depending on valve design, which bears on a gland in the stuffing box. Gland bolting should be tightened evenly to obtain the proper packing compression for leak-free service. Upon reassembling the valve, a few turns of the hand-wheel and a few drops of oil applied on the stem just above the packing will help work-in the packing to the stem.

(See page 133 for Gaskets and Packing Sets and page 134 for Bonnet assemblies)

## Care and Maintenance of Vogt Forged Steel Valves

### Disc and Seat

Leakage through the seat and disc is not always easy to detect, but when definitely known to exist, immediate repair is recommended since delay may permanently damage the disc, seat or both.

The internal repair of gate valves 2" and smaller is usually found to be uneconomical. However, if a gate valve is disassembled for inspection or cleaning, care should be taken when removing the wedge to note and mark its orientation with respect to the valve body so that when the wedge is reinserted in the valve, it will have precisely the same relationship to the seats that it had in the original assembly.

The seat threads in angle, globe and check valve bodies should be carefully inspected to make sure they are in usable condition. When installing new seats by using proper seat tools, the seats should be screwed tightly into the valve body, then unscrewed and examined to make sure they are making continuous contact for tight seal.

If seating surfaces show galling, slight pitting, grooving or indentations not deeper than 0.010", lapping will usually restore the surfaces sufficiently to permit tight closure. Defects deeper than 0.010" can seldom be corrected by lapping, but seating surfaces can be remachined or new parts installed. For re-lapping the seat and disc of Vogt globe, angle or check valves, uses a fine and a coarse grade emery base compound such as Clover Compound A and D. Apply a light coat of fine, or A, compound to the seating surface of the disc or one-piece stem, insert disc or one-piece stem into seat, and lap using an oscillating motion. Lap a few minutes and then wipe seating surfaces clean. This will clearly show the extent of damage. If severe damage is noted, use the coarse, or D, compound and lap until all defects are removed. Then finish with the fine, or A, compound. It is recommended that the face of the disc be "blued" to check for contact between seating surfaces after final lapping.

Globe and angle valves require a lapping guide fixture to maintain alignment during the lapping operation. A fixture as shown in GLOBE Figure may be made or, for O.S. and Y. valves, a valve bonnet with yoke nut removed may be used. For re-lapping loose disc globe valves, place a washer between the disc and head of the stem and retighten the disc nut, as shown in GLOBE Figure.

Vogt piston check valves require an adapter to screw or mate into the piston for lapping the piston seating surface to the seat. The bore of the valve body serves as a guide for lapping, see CHECK Figure. Ball check valves are primarily used for fluids of high viscosity and the rolling action of the ball maintains seating surfaces in good condition until ball size or ball guide is worn and replacement parts are needed.

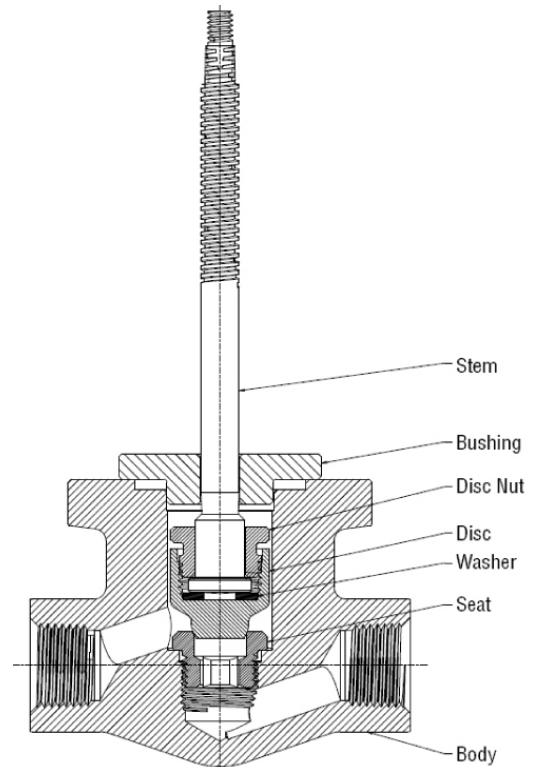

**GLOBE FIGURE**

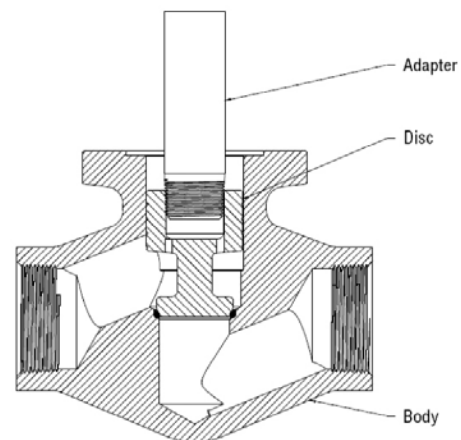

**CHECK FIGURE**

# Weight and Pressure Conversion

## Weight Conversion

### Pounds to Kilograms

(1 pound = 0.4536 kilograms)

Pounds	0	1	2	3	4	5	6	7	8	9
0	0.00	0.45	0.91	1.36	1.81	2.27	2.72	3.18	3.63	4.08
10	4.54	4.99	5.44	5.90	6.35	6.80	7.26	7.71	8.16	8.62
20	9.07	9.53	9.98	10.43	10.89	11.34	11.79	12.25	12.70	13.15
30	13.61	14.06	14.52	14.97	15.42	15.88	16.33	16.78	17.24	17.69
40	18.14	18.60	19.05	19.50	19.96	20.41	20.87	21.32	21.77	22.23
50	22.68	23.13	23.59	24.04	24.49	24.95	25.40	25.86	26.31	26.76
60	27.22	27.67	28.12	28.58	29.03	29.48	29.94	30.39	30.84	31.30
70	31.75	32.21	32.66	33.11	33.57	34.02	34.47	34.93	35.38	35.83
80	36.29	36.74	37.20	37.65	38.10	38.56	39.01	39.46	39.92	40.37
90	40.82	41.28	41.73	42.18	42.64	43.09	43.55	44.00	44.45	44.91

### Kilograms to Pounds

(1 kilograms = 2.2046 pounds)

Kilograms	0	1	2	3	4	5	6	7	8	9
0	0.00	2.20	4.41	6.61	8.82	11.02	13.23	15.43	17.64	19.84
10	22.05	24.25	26.46	28.66	30.86	33.07	35.27	37.48	39.68	41.89
20	44.09	46.30	48.50	50.71	52.91	55.12	57.32	59.52	61.73	63.93
30	66.14	68.34	70.55	72.75	74.96	77.16	79.37	81.57	83.77	85.98
40	88.18	90.39	92.59	94.80	97.00	99.21	101.41	103.62	105.82	108.03
50	110.23	112.43	114.64	116.84	119.05	121.25	123.46	125.66	127.87	130.07
60	132.28	134.48	136.69	138.89	141.09	143.30	145.50	147.71	149.91	152.12
70	154.32	156.53	158.73	160.94	163.14	165.35	167.55	169.75	171.96	174.16
80	176.37	178.57	180.78	182.98	185.19	187.39	189.60	191.80	194.01	196.21
90	198.41	200.62	202.82	205.03	207.23	209.44	211.64	213.85	216.05	218.26
90	40.82	41.28	41.73	42.18	42.64	43.09	43.55	44.00	44.45	44.91

## Pressure Conversion

### Bar to Pounds per Square Inch (psi)

(1 Bar = 105 Pa = 14.5 psi)

1 to 20		21 to 40		41 to 60		61 to 80		81 to 100	
Bar	psi	Bar	psi	Bar	psi	Bar	psi	Bar	psi
1	14.5	21	304.6	41	594.7	61	884.7	81	1174.8
2	29.0	22	319.1	42	609.2	62	899.2	82	1189.3
3	43.5	23	333.6	43	623.7	63	913.7	83	1203.8
4	58.0	24	348.1	44	638.2	64	928.2	84	1218.3
5	72.5	25	362.6	45	652.7	65	942.7	85	1232.8
6	87.0	26	377.1	46	667.2	66	957.2	86	1247.3
7	101.5	27	391.6	47	681.7	67	971.8	87	1261.8
8	116.0	28	406.1	48	696.2	68	986.3	88	1276.3
9	130.5	29	420.6	49	710.7	69	1000.8	89	1290.8
10	145.0	30	435.1	50	725.2	70	1015.3	90	1305.3
11	159.5	31	449.6	51	739.7	71	1029.8	91	1319.8
12	174.0	32	464.1	52	754.2	72	1044.3	92	1334.3
13	188.5	33	478.6	53	768.7	73	1058.8	93	1348.9
14	203.1	34	493.1	54	783.2	74	1073.3	94	1363.4
15	217.6	35	507.6	55	797.7	75	1087.8	95	1377.9
16	232.1	36	522.1	56	812.2	76	1102.3	96	1392.4
17	246.6	37	536.6	57	826.7	77	1116.8	97	1406.9
18	261.1	38	551.1	58	841.2	78	1131.3	98	1421.4
19	275.6	39	565.6	59	855.7	79	1145.8	99	1435.9
20	290.1	40	580.2	60	870.2	80	1160.3	100	1450.4

# Temperature Conversion

## Celsius (C) to Fahrenheit (F) - Fahrenheit (F) to Celsius (C)

-459.4° to 0°			1° to 60°			61° to 290°			300° to 890°			900° to 3000°		
C	Cel. or Fah.	F	C	Cel. or Fah.	F	C	Cel. or Fah.	F	C	Cel. or Fah.	F	C	Cel. or Fah.	F
-273	-459.4		-17.2	1	33.8	16.1	61	141.8	149	300	572	482	900	1652
-268	-450		-16.7	2	35.6	16.7	62	143.6	154	310	590	488	910	1670
-262	-440		-16.1	3	37.4	17.2	63	145.4	160	320	608	493	920	1688
-257	-430		-15.6	4	39.2	17.8	64	147.2	166	330	626	499	930	1706
-251	-420		-15.0	5	41.0	18.3	65	149.0	171	340	644	504	940	1724
-246	-410		-14.4	6	42.8	18.9	66	150.8	177	350	662	510	950	1742
-240	-400		-13.9	7	44.6	19.4	67	152.6	182	360	680	516	960	1760
-234	-390		-13.3	8	46.4	20.0	68	154.4	188	370	698	521	970	1778
-229	-380		-12.8	9	48.2	20.6	69	156.2	193	380	716	527	980	1796
-223	-370		-12.2	10	50.0	21.1	70	158.0	199	390	734	532	990	1814
-218	-360		-11.7	11	51.8	21.7	71	159.8	204	400	752	538	1000	1832
-212	-350		-11.1	12	53.6	22.2	72	161.6	210	410	770	549	1020	1868
-207	-340		-10.6	13	55.4	22.8	73	163.4	216	420	788	560	1040	1904
-201	-330		-10.0	14	57.2	23.3	74	165.2	221	430	806	571	1060	1940
-196	-320		-9.4	15	59.0	23.9	75	167.0	227	440	824	582	1080	1976
-190	-310		-8.9	16	60.8	24.4	76	168.8	232	450	842	593	1100	2012
-184	-300		-8.3	17	62.6	25.0	77	170.6	238	460	860	604	1120	2048
-179	-290		-7.8	18	64.4	25.6	78	172.4	243	470	878	616	1140	2084
-173	-280		-7.2	19	66.2	26.1	79	174.2	249	480	896	627	1160	2120
-169	-273	-459.4	-6.7	20	68.0	26.7	80	176.0	254	490	914	638	1180	2156
-168	-270	-454	-6.1	21	69.8	27.2	81	177.8	260	500	932	649	1200	2192
-162	-260	-436	-5.6	22	71.6	27.8	82	179.6	266	510	950	660	1220	2228
-157	-250	-418	-5.0	23	73.4	28.3	83	181.4	271	520	968	671	1240	2264
-151	-240	-400	-4.4	24	75.2	28.9	84	183.2	277	530	986	682	1260	2300
-146	-230	-382	-3.9	25	77.0	29.4	85	185.0	282	540	1004	693	1280	2336
-140	-220	-364	-3.3	26	78.8	30.0	86	186.8	288	550	1022	704	1300	2372
-134	-210	-346	-2.8	27	80.6	30.6	87	188.6	293	560	1040	732	1350	2462
-129	-200	-328	-2.2	28	82.4	31.1	88	190.4	299	570	1058	760	1400	2552
-123	-190	-310	-1.7	29	84.2	31.7	89	192.2	304	580	1076	788	1450	2642
-118	-180	-292	-1.1	30	86.0	32.2	90	194.0	310	590	1094	816	1500	2732
-112	-170	-274	-0.6	31	87.8	32.8	91	195.8	316	600	1112	843	1550	2822
-107	-160	-256	0.0	32	89.6	33.3	92	197.6	321	610	1130	871	1600	2912
-101	-150	-238	0.6	33	91.4	33.9	93	199.4	327	620	1148	899	1650	3002
-96	-140	-220	1.1	34	93.2	34.4	94	201.2	332	630	1166	927	1700	3092
-90	-130	-202	1.7	35	95.0	35.0	95	203.0	338	640	1184	954	1750	3182
-84	-120	-184	2.2	36	96.8	35.6	96	204.8	343	650	1202	982	1800	3272
-79	-110	-166	2.8	37	98.6	36.1	97	206.6	349	660	1220	1010	1850	3362
-73	-100	-148	3.3	38	100.4	36.7	98	208.4	354	670	1238	1038	1900	3452
-68	-90	-130	3.9	39	102.2	37.2	99	210.2	360	680	1256	1066	1950	3542
-62	-80	-112	4.4	40	104.0	37.8	100	212.0	366	690	1274	1093	2000	3632
-57	-70	-94	5.0	41	105.8	43	110	230	371	700	1292	1121	2050	3722
-51	-60	-76	5.6	42	107.6	49	120	248	377	710	1310	1149	2100	3812
-46	-50	-58	6.1	43	109.4	54	130	266	382	720	1328	1177	2150	3902
-40	-40	-40	6.7	44	111.2	60	140	284	388	730	1346	1204	2200	3992
-34	-30	-22	7.2	45	113.0	66	150	302	393	740	1364	1232	2250	4082
-29	-20	-4	7.8	46	114.8	71	160	320	399	750	1382	1260	2300	4172
-23	-10	14	8.3	47	116.6	77	170	338	404	760	1400	1288	2350	4262
-18	0	32	8.9	48	118.4	82	180	356	410	770	1418	1316	2400	4352
			9.4	49	120.2	88	190	374	416	780	1436	1343	2450	4442
			10.0	50	122.0	93	200	392	421	790	1454	1371	2500	4532
<b>Conversion Formulas</b>  $C = \frac{5}{9}(F - 32)$ $F = \frac{9}{5}C + 32$			10.6	51	123.8	99	210	410	427	800	1472	1399	2550	4622
			11.1	52	125.6	104	220	428	432	810	1490	1427	2600	4712
			11.7	53	127.4	110	230	446	438	820	1508	1454	2650	4802
			12.2	54	129.2	116	240	464	443	830	1526	1482	2700	4892
			12.8	55	131.0	121	250	482	449	840	1544	1510	2750	4982
			13.3	56	132.8	127	260	500	454	850	1562	1538	2800	5072
			13.9	57	134.6	132	270	518	460	860	1580	1566	2850	5162
			14.4	58	136.4	138	280	536	466	870	1598	1593	2900	5252
			15.0	59	138.2	143	290	554	471	880	1616	1621	2950	5342
			15.6	60	140.0	149	300	572	477	890	1634	1649	3000	5432



# Dimensional Data for Standard & Schedule Pipe

## Carbon Steel Pipe

NPS-Black numbers are inches and pounds DN-Blue numbers are millimeter and kilograms

PIPE	NPS DN	1/8 8	1/4 8	3/8 10	1/2 15	3/4 20	1 25	1 1/4 32	1 1/2 40	2 50	2 1/2 65	3 80	3 1/2 95	4 100	5 125	6 150	8 200	10 250	12 300
	Outside Dia.	0.405 10.3	0.540 13.7	0.675 17.1	0.840 21.3	1.050 26.7	1.315 33.4	1.660 42.2	1.900 48.3	2.375 60.3	2.875 73.0	3.500 88.9	4.000 101.6	4.500 114.3	5.563 141.3	6.625 168.3	8.625 219.1	10.750 273.0	12.750 323.8
Standard	Inside Dia.	0.269 6.8	0.364 9.2	0.493 12.5	0.622 15.8	0.824 20.9	1.049 25.6	1.380 35.1	1.610 40.9	2.067 52.5	2.469 62.7	3.068 77.9	3.548 90.1	4.026 102	5.047 128	6.065 154	7.981 203	10.020 255	12.000 305
	Wall Thick.	0.068 1.73	0.088 2.24	0.091 2.31	0.109 2.77	0.113 2.87	0.133 3.38	0.140 3.56	0.145 3.68	0.154 3.91	0.203 5.16	0.216 5.49	0.226 5.74	0.237 6.02	0.258 6.55	0.280 7.11	0.322 8.18	0.365 9.27	0.375 9.53
	Wt. Per Ft.	0.24 0.37	0.42 0.63	0.57 0.84	0.85 1.27	1.13 1.69	1.13 1.69	1.68 2.50	2.27 3.39	2.72 4.05	3.65 5.44	5.79 8.63	7.58 11.29	9.11 13.57	10.79 16.07	14.62 21.77	18.97 28.26	28.55 42.55	40.48 60.31
Extra Heavy	Inside Dia.	0.215 5.4	0.302 7.7	0.423 10.7	0.546 13.9	0.742 18.8	0.957 24.3	1.278 32.5	1.50 38.1	1.939 49.2	2.323 59.0	2.900 73.7	3.364 85.4	3.826 97.2	4.813 122	5.761 146	7.625 194	9.750 248	11.750 298
	Wall Thick.	0.095 2.41	0.119 3.02	0.126 3.20	0.147 3.73	0.154 3.91	0.179 4.55	0.191 4.85	0.200 5.08	0.218 5.54	0.276 7.01	0.300 7.62	0.318 8.08	0.337 8.56	0.375 9.53	0.432 10.97	0.500 12.70	0.600 12.70	0.600 12.70
	Wt. Per Ft.	0.31 0.47	0.54 0.80	0.74 1.10	1.09 1.62	1.47 2.20	1.47 2.20	2.17 3.24	3.00 4.47	3.63 5.41	5.02 7.48	7.66 11.41	10.25 15.27	12.50 18.63	14.98 22.32	20.78 30.97	28.57 42.56	43.39 64.64	54.74 81.55
Double Extra Heavy	Inside Dia.				0.252 6.4	0.434 11.0	0.599 15.2	0.896 22.6	1.100 27.9	1.503 36.2	1.771 5.0	2.300 58.4		3.152 80.1	4.063 103	4.897 124	6.875 175		
	Wall Thick.				0.294 7.47	0.308 7.82	0.358 9.09	0.382 9.70	0.400 10.15	0.436 11.07	0.552 15.24	0.600 15.24		0.674 17.12	0.750 19.05	0.864 21.95	0.875 22.23		
	Wt. Per Ft.				1.71 2.55	2.44 3.64	3.66 5.45	5.21 7.77	6.41 9.56	9.03 13.44	13.69 20.39	18.58 27.68		18.58 27.68	27.54 41.03	38.55 57.43	53.16 79.22	72.4 107.92	
Schedule 10	Inside Dia.																		
	Wall Thick.																		
	Wt. Per Ft.																		
Schedule 20	Inside Dia.																6.125 206	10.250 260	12.250 311
	Wall Thick.																0.250 6.35	0.250 6.35	0.250 6.35
	Wt. Per Ft.																22.36 33.31	28.04 41.77	33.38 49.73
Schedule 30	Inside Dia.																8.071 205	10.136 257	12.090 307
	Wall Thick.																0.277 7.04	0.307 7.80	*0.330 8.38
	Wt. Per Ft.																24.70 36.81	34.24 51.03	43.77 65.20
Schedule 40	Inside Dia.	0.269 6.8	0.364 9.2	0.493 12.5	0.622 15.8	0.824 20.9	1.049 26.6	1.380 35.1	1.610 40.9	2.067 52.5	2.469 62.7	3.068 77.9	3.548 90.1	4.026 102	5.047 128	6.065 154	7.981 203	10.020 255	11.938 303
	Wall Thick.	0.068 1.73	0.088 2.24	0.091 2.31	0.109 2.77	0.113 2.87	0.133 3.38	0.140 3.56	0.145 3.68	0.154 3.91	0.203 5.16	0.216 5.49	0.226 5.74	0.237 6.02	0.258 6.55	0.280 7.11	0.322 8.18	0.365 9.27	0.406 10.32
	Wt. Per Ft.	0.24 0.32	0.42 0.63	0.57 0.84	0.85 1.27	1.13 1.69	1.13 1.69	1.66 2.50	2.27 3.39	2.72 4.05	3.65 5.44	5.79 8.63	7.58 11.29	9.11 13.57	10.79 16.07	14.62 21.77	18.97 28.26	28.55 42.55	40.48 60.31
Schedule 60	Inside Dia.																7.813 198	9.750 248	11.626 295
	Wall Thick.																0.406 10.31	+0.500 12.70	0.562 14.27
	Wt. Per Ft.																35.64 53.08	54.74 81.55	73.15 108.96
Schedule 80	Inside Dia.	0.215 5.5	0.302 7.7	0.423 10.7	0.546 13.9	0.742 18.8	0.957 24.3	1.278 32.5	1.50 38.1	1.939 49.3	2.323 59.0	2.900 73.7	3.364 85.4	3.826 97.2	4.813 122	5.761 145	7.625 194	9.564 243	11.376 289
	Wall Thick.	0.095 2.41	0.119 3.02	0.126 3.20	0.147 3.73	0.154 3.91	0.179 4.55	0.191 4.85	0.200 5.08	0.218 5.54	0.276 7.01	0.300 7.62	0.318 8.08	0.337 8.56	0.375 9.53	0.432 10.97	0.500 12.70	0.594 15.02	0.688 17.48
	Wt. Per Ft.	0.31 0.47	0.54 0.80	0.74 1.10	1.09 1.62	1.47 2.20	1.47 2.20	2.17 3.24	3.00 4.47	3.63 5.41	5.02 7.48	7.66 11.41	10.25 15.27	12.51 18.63	14.98 22.32	20.78 30.97	28.57 42.56	43.39 64.64	64.43 96.01
Schedule 100	Inside Dia.																7.439 189	9.314 237	11.084 281
	Wall Thick.																0.594 15.09	0.719 18.26	0.844 21.44
	Wt. Per Ft.																50.95 75.92	77.03 114.75	107.32 159.91
Schedule 120	Inside Dia.													3.624 92.0	4.563 116	5.501 140	7.189 183	9.064 230	10.75 273
	Wall Thick.													0.438 11.13	0.500 12.70	0.562 14.27	0.719 18.26	0.844 21.44	1.000 25.40
	Wt. Per Ft.													19.00 26.32	27.04 40.28	36.39 54.20	60.71 90.44	89.24 133.06	125.49 186.97
Schedule 140	Inside Dia.																7.001 179	8.750 222	10.50 267
	Wall Thick.																0.812 20.62	1.000 25.40	1.125 28.58
	Wt. Per Ft.																67.76 100.92	104.13 155.15	139.67 208.14
Schedule 160	Inside Dia.				0.466 11.8	0.614 15.6	0.815 20.7	1.160 29.5	1.338 34.0	1.689 42.9	2.125 54.0	2.624 66.6		3.438 87.3	4.313 110	5.189 132	6.813 173	8.500 216	10.126 257
	Wall Thick.				0.188 4.78	0.219 5.56	0.250 6.35	0.250 6.35	0.281 7.14	0.344 8.74	0.375 9.53	0.438 11.13		0.531 13.49	0.625 15.88	0.719 18.26	0.906 23.01	1.125 28.58	1.312 33.32
	Wt. Per Ft.				1.31 1.95	1.94 2.90	2.84 4.24	3.76 5.61	4.86 7.25	7.46 11.11	10.01 14.92	14.32 21.35		22.51 33.54	32.96 49.11	45.35 67.56	74.69 111.27	115.64 177.33	160.27 238.76

## Dimensional Data for Standard & Schedule Pipe

**Stainless Steel Pipe**
*NPS-Black numbers are inches and pounds DN-Blue numbers are millimeter and kilograms*

PIPE	NPS DN	1/8 6	1/4 8	3/8 10	1/2 15	3/4 20	1 25	1 1/4 32	1 1/2 40	2 50	2 1/2 63	3 80	3 1/2 95	4 100	5 125	6 150	8 200	10 250	12 300
	Outside Dia.	0.405 10.3	0.540 13.7	0.675 17.1	0.840 21.3	1.050 26.7	1.315 33.4	1.660 42.2	1.900 48.3	2.375 60.3	2.875 73.0	3.500 88.9	4.000 101.6	4.500 114.3	5.563 141.3	6.625 168.3	8.625 219.1	10.750 273.1	12.750 323.9
Schedule 5S (a)	Inside Dia.				0.710 18.0	0.920 23.4	1.185 30.1	1.530 38.9	1.770 45.0	2.245 57.0	2.709 68.8	3.334 84.7	3.834 97	4.334 110	5.345 136	6.407 163	8.407 214	10.842 275	12.438 316
	Wall Thick.				0.065 1.65	0.065 1.65	0.065 1.65	0.065 1.65	0.065 1.65	0.065 1.65	0.083 2.11	0.083 2.11	0.083 2.11	0.083 2.11	0.109 2.77	0.109 2.77	0.109 2.77	0.134 3.40	0.156 3.96
	Wt. Per Ft.				0.54 0.80	0.69 1.03	0.87 1.29	1.11 1.65	1.28 1.90	1.61 2.40	2.48 3.69	3.03 4.51	3.48 5.18	3.92 5.83	6.36 9.46	7.60 11.31	9.93 14.78	15.19 22.61	20.98 31.22
Schedule 10S (a)	Inside Dia.	0.307 7.8	0.410 10.4	0.545 13.8	0.674 17.1	0.884 22.5	1.097 27.9	1.442 36.6	1.682 42.7	2.157 54.8	2.635 66.9	3.260 82.8	3.760 96	4.260 108	5.295 134	6.357 161	8.329 212	10.420 265	12.390 315
	Wall Thick.	0.049 1.24	0.065 1.65	0.065 1.65	0.083 2.11	0.083 2.11	0.109 2.77	0.109 2.77	0.109 2.77	0.109 2.77	0.120 3.05	0.120 3.05	0.120 3.05	0.120 3.05	0.134 3.40	0.134 3.40	0.148 3.76	0.165 4.19	0.180 4.57
	Wt. Per Ft.	0.19 0.28	0.33 0.49	0.42 0.63	0.67 1.00	0.86 1.28	1.40 2.08	1.81 2.69	2.09 3.11	2.64 3.93	3.53 5.25	4.33 6.44	4.97 7.40	5.61 8.35	7.77 11.56	9.29 13.83	13.40 19.94	18.65 27.75	24.17 36.0
Schedule 40S	Inside Dia.	0.269 6.8	0.364 9.2	0.493 12.5	0.622 15.8	0.824 20.9	1.049 26.6	1.380 35.1	1.610 40.9	2.067 52.5	2.469 62.7	3.068 77.9	3.548 90	4.026 102	5.047 128	6.065 154	7.981 203	10.020 255	11.938 303
	Wall Thick.	0.068 1.73	0.088 2.24	0.091 2.31	0.109 2.77	0.113 2.87	0.133 3.38	0.140 3.56	0.145 3.68	0.154 3.91	0.203 5.16	0.216 5.49	0.226 5.74	0.237 6.02	0.258 6.55	0.280 7.11	0.322 8.18	0.365 9.27	0.375 9.53
	Wt. Per Ft.	0.24 0.36	0.42 0.63	0.57 0.85	0.85 1.26	1.13 1.68	1.68 2.50	2.27 3.38	2.72 4.05	3.65 5.43	5.79 8.62	7.68 11.43	9.11 13.56	10.79 16.06	14.62 21.76	18.97 28.23	28.55 42.49	40.48 60.24	49.56 73.75
Schedule 80S	Inside Dia.	0.215 5.5	0.302 7.7	0.423 10.7	0.546 13.9	0.742 18.8	0.957 24.3	1.278 32.5	1.500 38.1	1.999 50.8	2.323 59.0	2.900 73.7	3.354 85	3.828 97	4.813 122	5.761 146	7.625 194	9.75 248	11.75 298
	Wall Thick.	0.095 2.41	0.119 3.02	0.128 3.25	0.147 3.73	0.154 3.91	0.179 4.55	0.200 4.85	0.218 5.08	0.218 5.54	0.276 7.01	0.300 7.62	0.318 8.08	0.337 8.56	0.375 9.53	0.432 10.97	0.500 12.70	0.500 12.70	0.500 12.70
	Wt. Per Ft.	0.31 0.46	0.54 0.80	0.74 1.10	1.09 1.62	1.47 2.19	2.17 3.23	3.00 4.46	3.53 5.25	5.02 7.47	7.66 11.40	10.25 15.25	12.50 18.60	14.98 22.29	20.78 30.92	28.57 42.52	43.39 64.57	54.74 81.46	65.42 97.36

(A) Wall thickness of schedule 5S and 10S does NOT permit threading in accordance with USA Standard Pipe Threads (ASME B1.20.1)

CARBON STEEL PIPE DATA: Extracted from ASME B36.10M-1985 Standards (except inside diameter and on size notation)  
 STAINLESS STEEL PIPE DATA: Extracted from ASME B36.19M-1985 Standards (except inside diameter and on size notation)

## **Limited Warranty**

Seller warrants that the Goods shall be free from defects in materials manufactured by Seller and in Seller's workmanship for a period of one (1) year following shipment (the "Warranty Period"). This limited warranty shall apply only in favor of Buyer, shall expire on the last day of such one (1) year period and shall be subject to the following:

- a. This warranty shall not apply to Goods that have been (i) repaired or altered by any Person other than the Seller, (ii) subjected to unreasonable or improper use or use beyond rated conditions, improper storage, negligence or accident, (iii) damaged because of use of the Goods or incorporation of the Goods into use of any Goods with other materials or equipment, after Buyer (or any other person using the Goods) has, or reasonably should have, knowledge of any defect; (iv) manufactured, fabricated or assembled by any person other than Seller (Seller shall assign to Buyer, to the extent same is assignable, any warranty Seller has received from the manufacture of such Goods); or (v) improperly installed by any person (including Buyer) other than Seller.
- b. This warranty shall not be effective unless Seller receives a written claim within thirty (30) days after discovery of any defect with respect to which a claim is made.
- c. Seller shall have the right (but not the obligation) to verify, with its own representatives, the nature and extent of any claimed defect prior to return of Goods to Seller. Upon request by Seller, Buyer shall, at its own risk and expense, promptly return the Goods in question to Seller's Plant.
- d. Buyer covenants to inform all subsequent buyers to the Goods of the limitations on and exclusion of the warranties provided herein. Buyer hereby indemnifies and agrees to hold Seller harmless from and against all losses, costs and expenses, including reasonable attorney's fees incurred by Seller as a result of any third-party claim relating to the purchase, sale or use of, otherwise relating to, the Goods covered by this agreement.
- e. Seller's liability for any breach of warranty shall be limited either to (i) repair or replacement (whichever Seller shall elect) at Seller's Plant of any Goods determined by Seller to be defective, or (ii) payment of an amount equal to the invoiced cost to the Buyer of the part or material that is defective, as Seller may elect. In no event shall Seller be required to repair, replace or reimburse Buyer for more than the part or material that is found to be defective and Seller's liability shall in no event be greater than the invoiced price of the item and shall not include labor, shipping or other costs incurred in connection with the reshipment of defective Goods to Seller or the reinstallation of such Goods after any repair or replacement. The Goods, as a whole, shall not be construed to be a "part" or "material" for the purpose of the immediately preceding sentence. Any Goods that are repaired or replaced by Seller shall be re-delivered to Buyer F.O.B. Seller's Plant and shall be warranted for the remaining term of the original Warranty Period for such Goods. THE REMEDY SET FORTH IN THIS LIMITED WARRANTY IS EXPRESSLY AGREED TO BE SOLE AND EXCLUSIVE REMEDY FOR ANY SUCH BREACH OF WARRANTY.
- f. THIS LIMITED WARRANTY IS IN LIEU OF ALL OTHER WARRANTIES (EXCEPT OF TITLE), EXPRESS, IMPLIED OR STATUTORY, INCLUDING WITHOUT LIMITATION ANY IMPLIED OR EXPRESS WARRANTIES OF MERCHANTABILITY, FITNESS FOR A PARTICULAR PURPOSE AND CONFORMITY TO MODELS OR SAMPLES. ALL OTHER LIABILITY WHETHER IN CONTRACT OR TORT, STRICT LIABILITY, NEGLIGENCE OR OTHERWISE, IS HEREBY EXCLUDED.

