

T-17
CATALOG

Vogt®



Ball
Valves



Vogt Valves

A History in the Making

In the late 1890s, Vogt pioneered the early development of ammonia absorption refrigeration systems that made artificial ice. This business, plus Vogt's fledgling boiler business, created an internal need for quality valves that initiated Vogt's early entry into the valve manufacturing business.

The early reputation of Vogt's quality valves and rapidly growing petroleum processing industry created an outside demand that would firmly establish Vogt in the mass production of high-quality forged steel valves.

For more than 100 years, Vogt's leadership has been evident in the production of forged steel gate, globe, angle and check valves in most popular materials, trims and bonnet configurations.

Today, Vogt valves support a worldwide network of distributors with access to the world's largest capability for manufacturing of forged steel valves.

Vogt Valves introduces a new line of Floating and Trunnion Ball Valves

RANGE

We offer Trunnion Mounted ball valves from 1/2" to 60"
We complete our offer with Floating ball valves from 1/4" to 6".
All available in ASME class 150, 300, 600, 900, 1500 and 2500.

CONSTRUCTION

Vogt Ball valves are designed in full compliance with the requirements set forth by API 6D and API 608.

FUGITIVE EMISSION

Vogt Floating Ball Valves are tested and certified to API641.
Vogt Trunnion Mounted Ball valves are available certified to ISO15848

FIRE SAFE

Vogt Ball Valves have been fully tested and certified fire safe according to API 607 and API6FA

MATERIALS

BODY

We offer a wide range of forged material for the body.
All components are made from USA or European materials only

TRIM

From SS316 to Alloy625, we can supply trim components to meet standard or severe service applications.
All components are made from USA or European materials only

SEAT AND SEAL

Vogt Ball Valves are available in a wide range of Thermoplastic Seats and Elastomeric and Thermoplastic Seal

TESTING TO API 598 and API6D

All our Ball valves are tested either to API598 or API6D at our facilities in Stafford, TX and Settimo Milanese, Italy.
We are able to perform special tests such as High Pressure Gas, Cryogenic, High Temperature



Product Range

Floating and Trunnion

	FLOATING						TRUNNION					
	FORGED						FORGED					
	RB-FB						RB-FB					
	#150	#300	#600	#900	#1500	#2500	#150	#300	#600	#900	#1500	#2500
1/2"	Orange	Orange	Orange	Orange	Orange	Orange						
3/4"	Orange	Orange	Orange	Orange	Orange	Orange						
1"	Orange	Orange	Orange	Orange	Orange	Orange						
1.1/2"	Orange	Orange	Orange	Orange	Orange	Orange						
2"	Orange	Orange	Orange	Orange	Orange	Orange	Green	Green	Green	Green	Green	Green
3"	Orange	Orange	Orange	Orange	Orange	Orange	Green	Green	Green	Green	Green	Green
4"	Orange	Orange	Orange	Orange	Orange	Orange	Green	Green	Green	Green	Green	Green
6"	Orange	Orange	Orange	Orange	Orange	Orange	Green	Green	Green	Green	Green	Green
8"							Green	Green	Green	Green	Green	Green
10"							Green	Green	Green	Green	Green	Green
12"							Green	Green	Green	Green	Green	Green
14"							Green	Green	Green	Green	Green	Green
16"							Green	Green	Green	Green	Green	Green
18"							Green	Green	Green	Green	Green	Green
20"							Green	Green	Green	Green	Green	Green
22"							Green	Green	Green	Green	Green	Green
24"							Green	Green	Green	Green	Green	Green
26"							Green	Green	Green	Green	Green	Green
28"							Green	Green	Green	Green	Green	Green
30"							Green	Green	Green	Green	Green	Green
32"							Green	Green	Green	Green	Green	Green
34"							Green	Green	Green	Green	Green	Green
36"							Green	Green	Green	Green	Green	Green
40"							Green	Green	Green	Green	Green	Green
42"							Green	Green	Green	Green	Green	Green
48"							Green	Green	Green	Green	Green	Green
56"-60"							Green	Green	Green	Green	Green	Green

	FLOATING	TRUNNION
Body design	Closed Dye Forging Forged bar	Ring Forgings
Valve construction	2 or 3 Pieces	3 Pieces
Size range	size 1/2" to 6"	1.1/2" to 60"
ASME classes	150, 300, 600, 800, 1500	150, 300, 600, 1500, 2500
Specification reference	API608 - ISO17292	API6D - ISO 14313
Seat Design	Soft and Metal Seated	Soft and Metal Seated
Fire Safe	Certified	Certified
Bore dimension	Full and Standard Bore	Full and Standard Bore

Product Range

Floating SERIE F-2C



SIDE ENTRY

- 2 or 3 pieces
- Size 1/2" to 6"
- Soft and Metal Seated
- Class 150, 300, 600, 800, 1500
- Full and Standard Bore
- Fire safe certified
- Reference API608
ISO 17292

Floating

API 608 - SERIE F2C

- Size 1/2" to 6"
- Full & Conventional Port
- Fire Safe to API607
- 2 pieces, side entry,
- Bolted closure

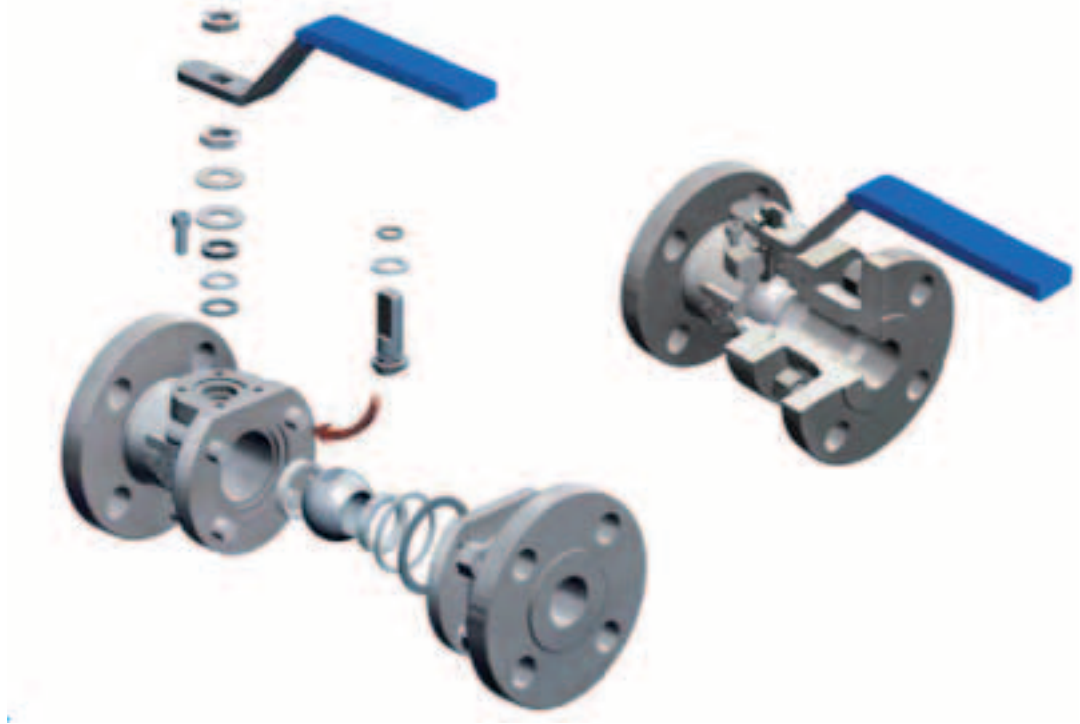

Design Standards	API 608 – ISO 17292
ASME Class	150, 300, 600, 900, 1500, 2500
Body Construction	2 pieces, bolted
Fire Safe	API 607
Body Feature	Forged Steel
Bore	Conventional and Full Bore
Packing	Fugitive Emission Packing qualified to API641
Stem	Anti-Blowout and Antistatic design
Seat	Soft Seated, Thermoplastic and Metal Seated, Tungsten Carbide Coating
Seal	Elastomer O-Ring + Graphite
Valve Ends	Flanged
End-to-End dimensions	ASME standard

Floating Ball Valves

Product Range

SIZE	150	300	600	1500
½"				
¾"				
1"				
1.½"				
2"				
3"				
4"				
6"				

Series (Full bore)

BODY	TRIM	SEAL	150	300	600	1500
A105N	316+RPTFE	FKM AED	F2C-F1F-1	F2C-F3F-1	F2C-F6F-1	F2C-F5F-1
LF2	316+RPTFE	FKM GLT	F2C-F1F-2	F2C-F3F-2	F2C-F6F-2	F2C-F5F-2
F316	316+RPTFE	FKM AED	F2C-F1F-3	F2C-F3F-3	F2C-F6F-3	F2C-F5F-3

Ends configuration code is added in front of the serie: ie. NPT= 1601, SW= SW1610

	NPT	SW	SW - NPT	NPT - SW	PUPS
ENDS	T	S	SW	TS	P

DESCRIPTION	A105/316	LF2/316	F316/316
LEVER NUT	Carbon Steel	Carbon Steel	Carbon Steel
NAMEPLATE	Aluminium	Aluminium	Aluminium
LEVER	Carbon Steel	Carbon Steel	Carbon Steel
PACKING	Graphite	Graphite	Graphite
GLAND	Stainless Steel	Stainless Steel	Stainless Steel
PACKING+STEM GASKET	PTFE+25% Fiberglass	PTFE+25% Fiberglass	PTFE+25% Fiberglass
BOLTS	A193 B7	A320 L7	A193 B8
SPRING	Harmonic Steel	Harmonic Steel	Harmonic Steel
STEM	st/st 316	st/st 316	st/st 316
END CONNECTOR	A105N	A350 LF2	A182 F316
BODY GASKET	PTFE+15% Glass	PTFE+15% Glass	PTFE+15% Glass
SEATS	PTFE+15% Glass	PTFE+15% Glass	PTFE+15% Glass
BODY	A105N	A350 LF2	A182 F316
BALL	st/st 316	st/st 316	st/st 316
FIRE SAFE GASKET	Graphite	Graphite	Graphite
STEM O-RING	FKM*	FKM*	FKM*

Floating Ball Valves

Full Port

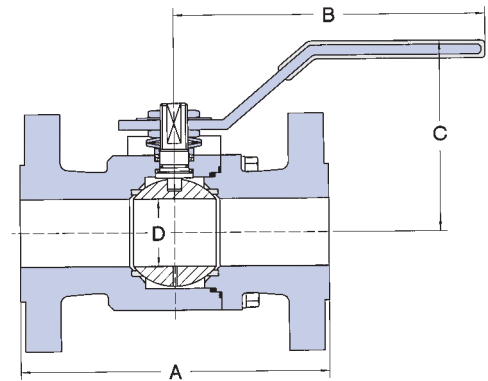

F-2C-F1F - CLASS 150

FULL BORE SIDE TWO PIECE BALL VALVES BODY
Integral Flanged - End According to ASME 16.10

SIZE		1/2"		3/4"		1"		1 1/2"		2"		3"		4"		6"	
		in.	mm	in.	mm	in.	mm	in.	mm	in.	mm	in.	mm	in.	mm	in.	mm
End to End	A	108	4.3	117	4.6	127	5	165	6.5	178	7.0	203	8.0	229	9.0	394	15.5
Lever	B	155	6.1	170	6.7	170	6.7	230	9.1	310	12.2	400	15.7	500	19.7	**	**
Center Top to Open	C	75	3.0	98	3.9	100	3.9	135	5.3	155	6.1	150	5.9	190	7.5	190	7.5
Ball Bore	D	14.2	0.6	20.5	0.8	25.4	1.0	38	1.5	51	2.0	76	3.0	102	4.0	102	4.0

*Gear operator suggest

F-2C-F3F - CLASS 300

FULL BORE SIDE TWO PIECE BALL VALVES BODY
Integral Flanged - End According to ASME 16.10

SIZE		1/2"		3/4"		1"		1 1/2"		2"		3"		4"		6"	
		in.	mm	in.	mm	in.	mm	in.	mm	in.	mm	in.	mm	in.	mm	in.	mm
End to End	A	140	5.5	153	6.0	165	6.5	191	7.5	216	8.5	283	11.1	305	12.0	**	**
Lever	B	155	6.1	170	6.7	170	6.7	230	9.1	310	12.2	400	15.7	**	**	**	**
Center Top to Open	C	76	3.0	98	3.9	100	3.9	135	5.3	155	6.1	150	5.9	182	7.2	**	**
Ball Bore	D	14.2	0.6	20.5	0.8	25.4	1.0	38	1.5	51	2.0	76	3.0	102	4.0	**	**

*Gear operator suggest

F-2C-F6F - CLASS 600

FULL BORE SIDE TWO PIECE BALL VALVES BODY
Integral Flanged - End According to ASME 16.10

SIZE		1/2"		3/4"		1"		1 1/2"		2"		3"		4"		6"	
		in.	mm	in.	mm	in.	mm	in.	mm	in.	mm	in.	mm	in.	mm	in.	mm
End to End	A	165	6.5	191	7.5	216	8.5	241	9.5	292	11.5	356	14.0	432	17.0	**	**
Lever	B	155	6.1	170	6.7	170	6.7	230	9.1	310	12.2	450	17.7	**	**	**	**
Center Top to Open	C	76	3.0	98	3.9	100	3.9	135	5.3	155	6.1	200	7.9	244	9.6	**	**
Ball Bore	D	14.2	0.6	20.5	0.8	25.4	1.0	38	1.5	51	2.0	76	3.0	102	4.0	**	**

*Gear operator suggest

F-2C-F5F - CLASS 1500

FULL BORE SIDE TWO PIECE BALL VALVES BODY
Integral Flanged - End According to ASME 16.10

SIZE		1/2"		3/4"		1"		1 1/2"		2"		3"		4"		6"	
		in.	mm	in.	mm	in.	mm	in.	mm	in.	mm	in.	mm	in.	mm	in.	mm
End to End	A	216	8.5	229	9.0	254	10.0	305	12.0	368	14.5	**	**	**	**	**	**
Lever	B	170	6.7	170	6.7	230	9.1	310	12.2	400	15.7	**	**	**	**	**	**
Center Top to Open	C	86	3.4	120	4.7	120	4.7	140	5.5	170	6.7	**	**	**	**	**	**
Ball Bore	D	14.2	0.6	20.5	0.8	25.4	1.0	38	1.5	51	2.0	**	**	**	**	**	**

*Gear operator suggest

Seat Materials

	VOGT DESIGNATION	CHEMICAL NAME/DESIGNATION	TEMPERATURE RANGE	APPLICATION	TRADEMARK
THERMOPLASTIC	P.T.F.E	Polytetrafluoroethylene	-100° to + 180°/220°C	Virgin PTFE is used as a standard material for its high lubricity and superior sealing up to 180°C. It is white in colour.	DuPont™ Teflon®
	R.P.T.F.E/Glass	Polytetrafluoroethylene glass filled	-100° to + 200°/250°C	Reinforced PTFE seats are made with glass filled PTFE (20%). They are harder than virgin PTFE. White in colour with green or blue speckles.	DuPont™ Teflon®
	R.P.T.F.E/Carbon Graphite	Polytetrafluoroethylene carbon-graphite filled	-100° to + 200°/250°C	Reinforced PTFE with 20% carbon and 5% Graphite. These seats are black in colour.	-
	POM (Delrin®)	Polyoxymethylene acetal resin	-57°C to 82°C	This material is very rigid it has a combination of strength, stiffness, hardness dimensional stability, toughness, fatigue resistance, abrasion resistance low wear and low friction. It can withstand pressure up to 5000 PSIG depending on valve size. Do not use on oxygen service.	DuPont™ Delrin®
	Devlon® V	Polyamide	-100° to +150°C	Devlon® V is similar to Nylon 12G, but with a wider range of temperature application (lower and higher).	Devol Eng. Ltd.
	PEEK	Polyetheretherketone	-100° to 260°C	Peek is recommended for high temperature (up to 260°C) but it is very hard compared to other non metallic materials. Not applicable for concentrated sulphuric acid.	-
	PCTFE (Kel F®)	Polychlorotrifluoroethylene	-250° + 150°C	PCTFE is specifically recommended for cryogenic service.	3-M™ KEL-F® Daikin™ Neoflon®
	VespeI® Sp21	15% Graphite Filled Polyimide	-100° to 340°C	15% Graphite filler. Performs well in a variety of chemical environments and a variety of industrial fluids at elevated temperatures.	DuPont™ VespeI®
	Nylon 12 G	Polyamide	-50° to + 120°C	Nylon 12G is more suitable than PTFE for higher pressure, but has a limited range in temperature.	-
	UHMWPE	Ultra High Molecular Weight Polyethylene	-200°C to 80°C	UHMWPE (05) is a common substitute where PTFE is not permitted and has excellent abrasion resistance.	-

C	-250°	-200°	-150°	-100°	-50	0	50°	100°	150°	200°	250°	300°	350°
F	-148	-328	+238	-148	-58	32	122	212	302	392	482	572	662

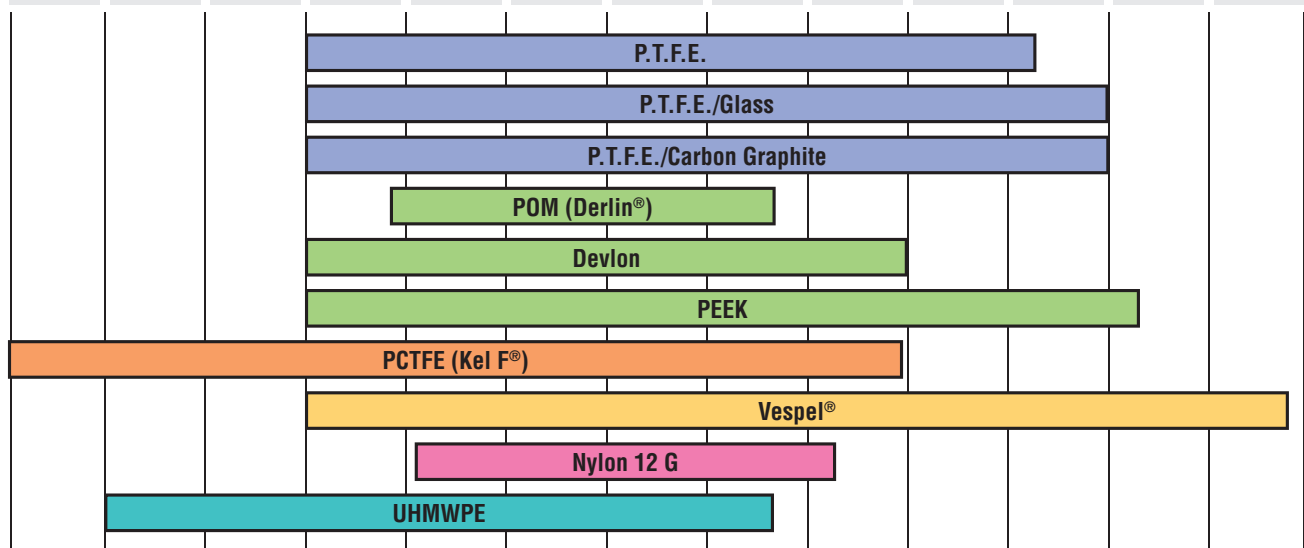

Seal Materials

SEAL TYPE	DEFINITION/BRAND	MAKER	AED GRADE	MIN	MAX T
FPM (FKM ASTM grade)	Fluoroelastomer				
FPM (FKM ASTM grade)	Viton®	® DuPont	AED	-30C	200C
FPM (FKM ASTM grade)	FR58/90	® J Walker	AED	-30C	200C
HNBR	Hydrogenated Nitrile				
HNBR	ELAST-O-LION®101	® J Walker		-29C	160C
HNBR	ELAST-O-LION®985	® J Walker	AED	-55C	150C
TFE/P (FEPM ASTM grade)	Tetrafluoroethylene/Propylene				
FEPM (Atlas®)	AF 85/90	® Asahi Chem	AED	0	200C
FFPM (FFKM ASTM grade)	Perfluoroelastomer				
FFPM (FFKM ASTM grade)	Kalrez® 1050 LF	® DuPont		5C	365C
FFPM (FFKM ASTM grade)	Kaflon 72B	TM GMI		-25C	315C

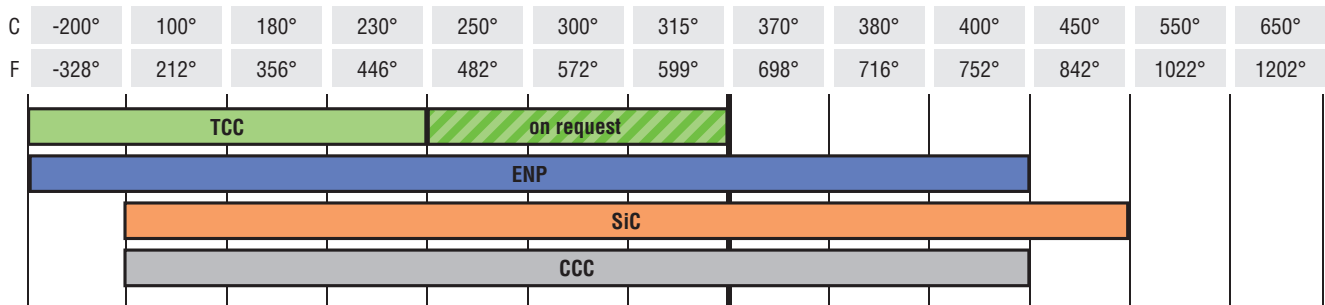
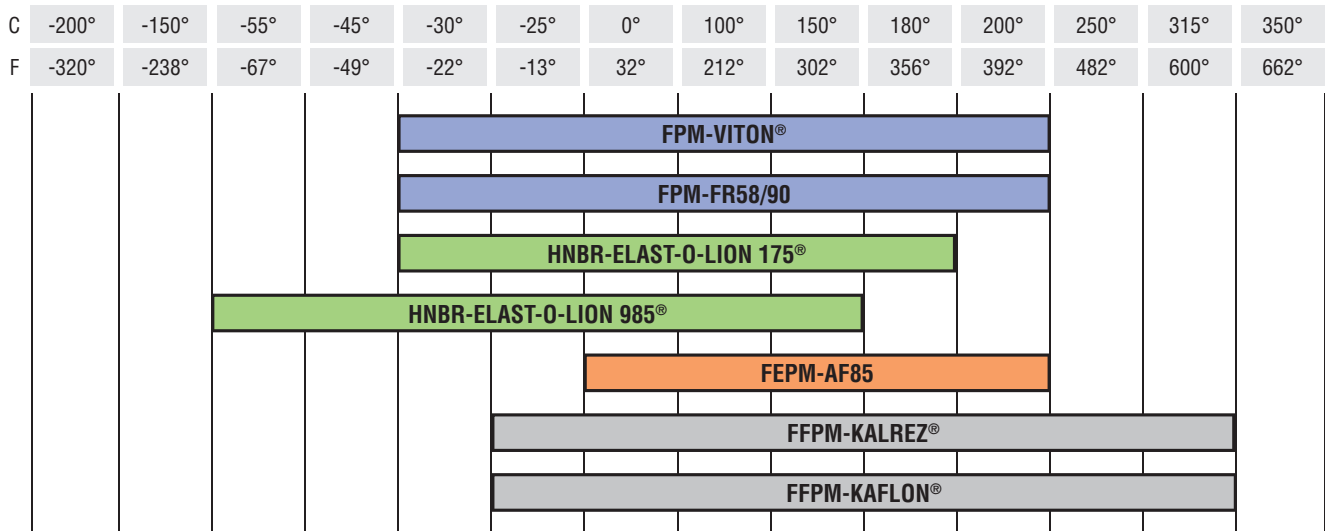

Upper limit of KAFLON/KALREZ®

Graphite seat seal - Special design/torque

Valves Design

Trunnion		Features
B	Bearing Plate	Bearing plates are used on large size valves as standard
T	Trunnion	External trunnion is used on small size valves

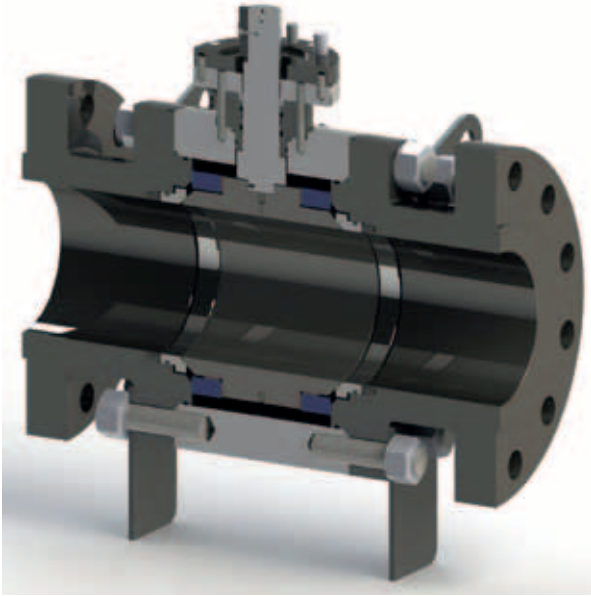

*B type: bearing plate construction
BSE type: Bearing Plate construction*

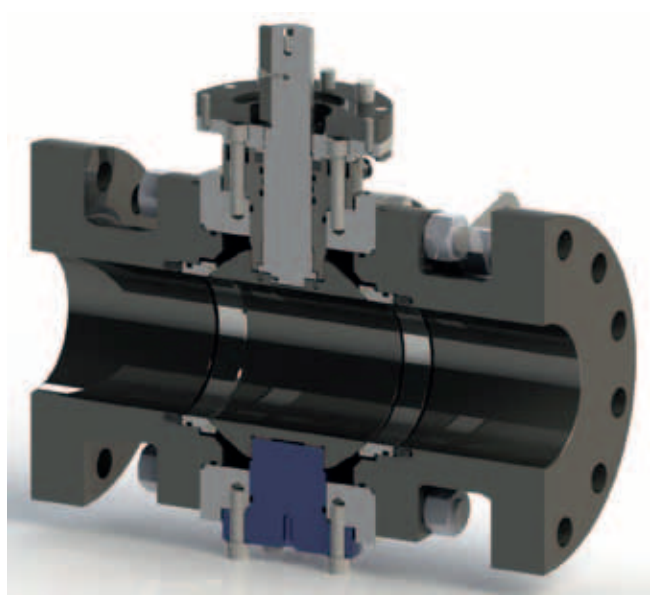

*T type: external trunnion construction
BSH type: External Trunnion construction*

End to End		Features	
L	Long pattern	End to end to ASME B1610 Long Pattern is standard	
S	Short pattern	End to end to ASME B1610 Short Pattern is available	on request
A	Special	Special lengths to customer specification are available on request	on request



Short Pattern



Lugged



Special lengths

Vogt Ball valves can be supplied in the following configurations

- Flanged to ASME/ANSI standards
- Flanged to DIN and GOST standards
- Compact Flanges to Norsok L005 or special design
- Butt Weld Ends with or without transitions pups
- Hub connectors

Seat Design & Materials

We offer a number of different seats sealing configurations according to service conditions

THERMOPLASTIC SEAT INSERTS with ORING

This configuration is standard and used for most applications. We offer a wide selection of Elastomer oring seals. Please see following page for seal selection and properties

THERMOPLASTIC SEAT INSERT with LIP SEALS

In low temperature and cryogenic services we offer as a standard a Thermoplastic insert with LIP SEAL Single or Double Lip Seals sealing are available according to service requirements

METAL SEAT with ORING

In severe service we offer a seat configuration with metal sealing in either Tungsten Carbide, Chrome Carbide or Silicon Carbide and

METAL SEAT with GRAPHITE SEAL

In high temperature configuration we offer a metal sealing in Chrome Carbide or Silicon Carbide with graphite seals Seat Type

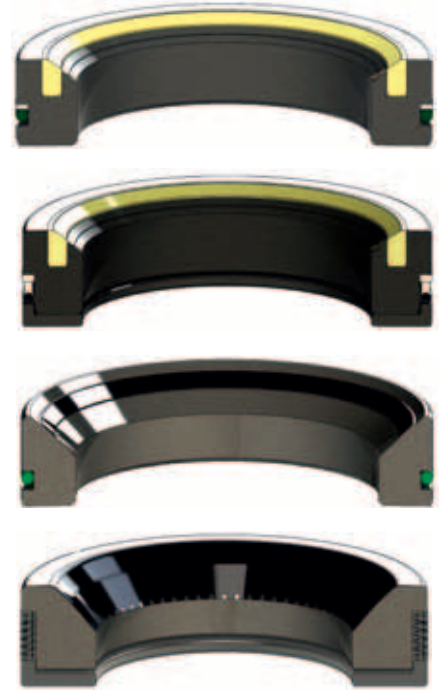

Seat Type		Features	
SS	SPE x SPE	A dual set of Single Piston Effect seat is Vogt standard offer	
DD	DPE x DPE	Double piston effect on both seats are available on request	on request
SD	SPE x DPE	Combination Single and Double Piston Effect are available on request	on request
DS	DPE x SPE	Combination Single and Double Piston Effect are available on request	on request

SINGLE PISTON EFFECT

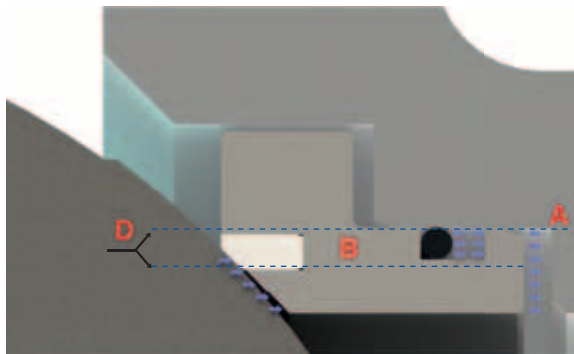

As line pressure increases, the seat differential area $D = A - B$ creates a piston effect forcing the seat on the ball: higher the line pressure, tighter the piston action.

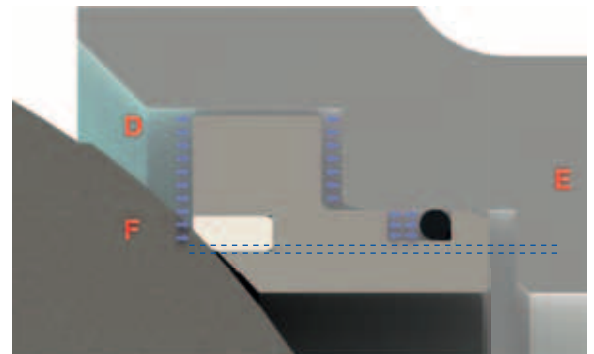

If pressure grows up into the cavity, it relieves to the line as differential area $F = D - E$ has greater force than the spring load.

DOUBLE PISTON EFFECT

Seat seal may be designed to provide additional sealing capability: the cavity pressure enhances the contact pressure between seat and ball, as differential area $D = A - B$ creates a piston effect forcing the seat on the ball (a pressure relief valve is installed to protect the cavity by excess pressure).

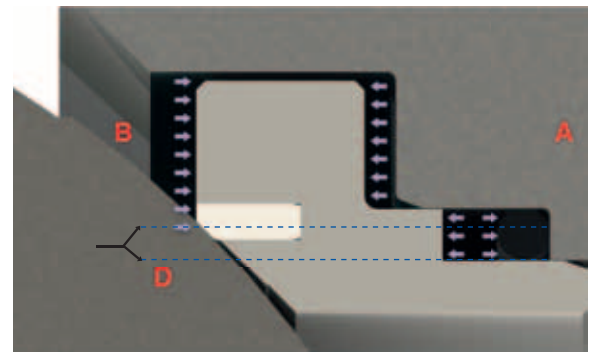

Operators

Vogt standards design offer levers or gear operators in accordance to the below tables

Operator			
L	Lever	Standard application for low torque valves	
G	Gear	Standard application for high torque valves	
B	Bare stem	On request valves can be supplied bare stem	on request
S	Spring return	Spring return (either standard or pneumatically assisted) are available	on request
A	Lever+lock device	Locking devices are available	on request
B	Lever+padlock	Padlock are available	on request
C	Gear+lock device	Locking devices are available	on request
D	Gear+padlock	Padlock are available	on request
E	Gear+chain	Chain operated gear are available	on request
R	ROV	SubSea valves can be equipped with ROV operator	on request

Lever heads are in forged material with lever made from 3/4" Sch 160 CS pipe



L - Lever: standard design



B - Lever + padlock: on request

Floating - soft seated

	150	300	600	900	1500	2500
1/2"	Lever	Lever	Lever	Lever	Lever	Lever
3/4"	Lever	Lever	Lever	Lever	Lever	Lever
1"	Lever	Lever	Lever	Lever	Lever	Lever
1.1/2"	Lever	Lever	Lever	Lever	Lever	Gear
2"	Lever	Lever	Lever	Lever	Lever	Gear
3"	Lever	Lever	Gear			
4"	Lever	Gear	Gear			
6"	Gear	Gear	Gear			

Trunnion mounted - soft seated

	150	300	600	900	1500	2500
3/4"	Lever	Lever	Lever	Lever	Lever	Lever
1"	Lever	Lever	Lever	Lever	Lever	Lever
1.1/2"	Lever	Lever	Lever	Lever	Gear	Gear
2"	Lever	Lever	Lever	Lever	Gear	Gear
3"	Lever	Lever	Gear	Gear	Gear	Gear
4"	Lever	Lever	Gear	Gear	Gear	Gear
6"	Lever	Lever	Gear	Gear	Gear	Gear
>8"	Gear	Gear	Gear	Gear	Gear	Gear

Floating - metal seated

	150	300	600	900	1500	2500
1/2"	Lever	Lever	Lever	Gear	Gear	Gear
3/4"	Lever	Lever	Lever	Gear	Gear	Gear
1"	Lever	Lever	Lever	Gear	Gear	Gear
1.1/2"	Lever	Lever	Lever	Gear	Gear	Gear
2"	Lever	Lever	Gear	Gear	Gear	Gear
3"	Gear	Gear	Gear			
4"	Gear	Gear	Gear			
6"	Gear	Gear	Gear			

Trunnion mounted - metal seated

	150	300	600	900	1500	2500
3/4"	Gear	Gear	Gear	Gear	Gear	Gear
1"	Gear	Gear	Gear	Gear	Gear	Gear
1.1/2"	Gear	Gear	Gear	Gear	Gear	Gear
2"	Gear	Gear	Gear	Gear	Gear	Gear
3"	Gear	Gear	Gear	Gear	Gear	Gear
4"	Gear	Gear	Gear	Gear	Gear	Gear
6"	Gear	Gear	Gear	Gear	Gear	Gear
>8"	Gear	Gear	Gear	Gear	Gear	Gear

Vent and Drain

Vogt offer as standard vent and drain with hole size according to the below table. Vent and drain material same as body.

Vent: as standard: Blind plug Threaded NPT, other option on request
 Drain: as standard Check valve Threaded NPT, other option on request

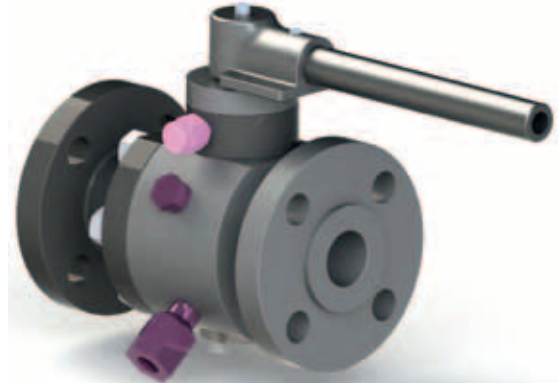

Vent and Drain	
A	Vent + Drain separated
C	Vent + Drain combined
V	Vent (only)
D	Drain (only)
X	None

Design	Vent	Drain
	Blind NPT pulg	NPT check
<1"	1/4"	1/4"
1.1/2"	1/2"	1/2"
2"	1/2"	1/2"
3"	1/2"	1/2"
4"	3/4"	3/4"
6"	3/4"	3/4"
>8"	1"	1"

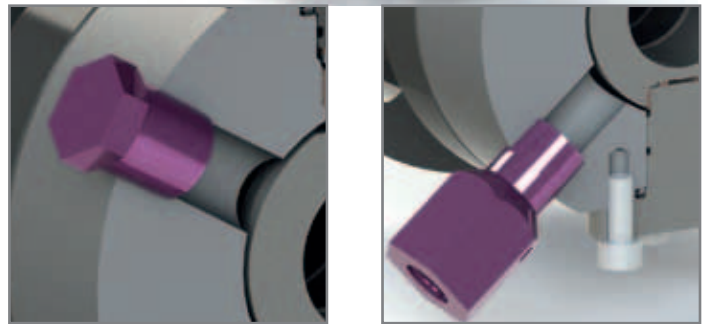

Sealant Injectors

Emergency sealant injection is available on request to restore sealing integrity in case of damaged sealing surfaces

Stem Sealant injectors

Vogt offer as standard a stem sealant injector

Seat Sealant injectors

An emergency sealant injection system through the seat up to the ball contact circle may provide temporary sealing until the time when it is possible to restore the primary seal.

Vogt offer seat injection on request.

Grease injectors	
S	Steam
T	Seat
A	Steam + Seat
X	None

Design	Injector	Injector
	on stem	on seats
<1"	no	on request
1.1/2"	yes	on request
2"	yes	on request
3"	yes	on request
4"	yes	on request
6"	yes	on request
>8"	yes	on request

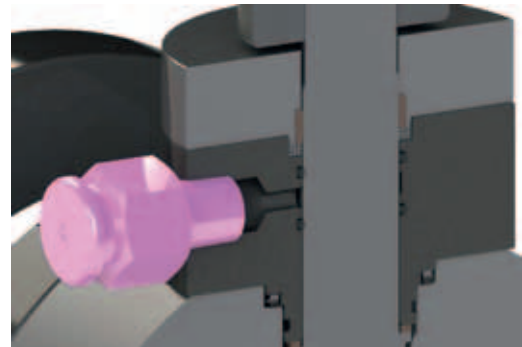

Stem Sealant injector



Seat Sealant injector

Antistatic

Internal parts that are insulated from the body may build up a static electric charge. When service conditions require electrical continuity to prevent static discharge, this is ensured by the adoption of coil springs between body, ball and stem. This feature is standard on both Trunnion and Floating type valves

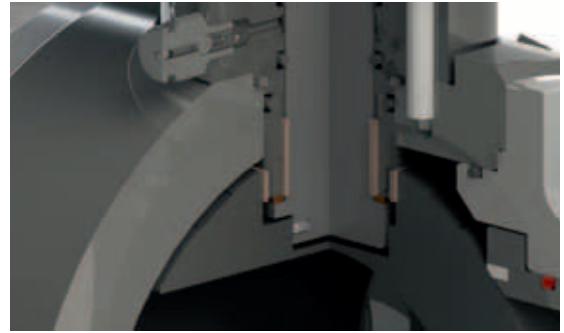

Anti-Blowout

The design of the valve ensures that the stem cannot be blown out of the body, in the event of the gland being removed while the valve is under pressure. This feature is standard on both Trunnion and Floating type valves

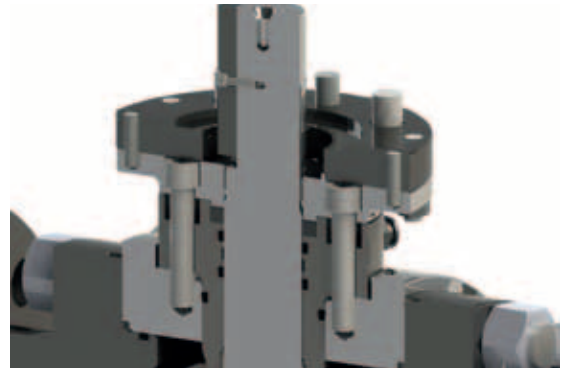

Supports

Cradle / Feet

Vogt valves are equipped with Cradle/feet as per below table

Design	Feet	Cradle
<1"	no	no
1.1/2"	no	no
2"	no	no
3"	no	no
4"	no	no
6"	no	no
>8"	standard	on request



Lifting Lugs

Lifting Lugs

All valves above 8" have lifting lugs as per API6D requirements Vogt offer as standard lifting lugs on valves above 500 Lbs

Design	Lifting Lugs
<1"	no
1.1/2"	no
2"	no
3"	no
4"	no
6"	no
>8"	standard



Floating Ball Valves

Vogt Floating Ball Valves serie F2C are built to API608 with encapsulated seats, stem seals certified to API641 for lowemission, designed and certified Fire Safe with double body gasket. All our products are manufactured from forgings and components sourced in US and Europe only.

Ball

Balance hole

All our floating ball valves are supplied with a cavity **pressure balance hole** in the ball as standard.

On request or for special end user requirements we can supply ball with **no cavity hole**

Bleed Holes

Bleed Holes are provided for upstream pressure relief on cryogenic service valves.



Stem

Anti-Blowout

All our floating ball valves are supplied with an anti blow-out stem as standard
The stem and the stem/ball connection are designed to API608 para 5.5.3 (grated of 20NM or 2 time max torque)

Anti Static

All our floating ball valves are supplied with an integral antistatic design. The bottom of the stem is in contact with the ball via a spring activated pin which ensure continuous antistatic contact



Lever

Lever: Zinc Plated Carbon Steel

with Epoxy coating on handle.

On request we provide:

- Locking device
- Levers in Stainless Steel
- Self locking
- Oval handwheel



Options

Actuators

Pneumatic or Hydraulic actuators are available for all valves

Self Closing Lever

Self closing lever are availale on all series



How to order

Floating

EXAMPLE

F	2	C
Floating Ball valves	2 pieces	Bolted
TYPE	BODY DESIGN	TYPE
F Floating BV	1 1 piece	A Threaded Seal Weld
	2 2 pieces	B Threaded
	3 3 pieces	C Bolted
		W Welded
		T Top Entry

F
RF Raised Face Flanged
ENDS
F Raised Face Flanged
B Butt Weld
J Ring Joint Flanged
H Hub Ends
S Socket Weld
T Threaded
ST Socket x Threaded
TS Threaded x Socket
P Integral Pups pieces

	<i>1</i>	<i>F</i>
--	----------	----------

150

Full Port

CLASS

1	150
2	300
3	600
8	800
5	1500
2	2500

PORT

R	Reduced
F	Full

<i>1</i>	<i>N</i>
----------	----------

A105N

NACE trim

BODY MATERIAL

1	A105N Carbon Steel, 316 trim
2	LF2 Low Temp Carbon Steel, 316 trim
3	F316 Stainless Steel, 316 trim
5	F51 Duplex Steel, Duplex trim
A	Aluminium Bronze, AlBr trim

SPECIAL SERVICE / FEATURES

N	NACE Trim
CRY	Cryogenic Service
EXT	Extended Bonnet (Non-Cryo)
M2M	M2M = Metal Seated
G	Gear operated
MO	Motor operated
AO	Air (Pneumatic) Operated

