

COSPECT[®] STEAM PRESSURE REDUCING VALVE

MODEL **COS-3/COS-16**
DUCTILE CAST IRON, CAST IRON
STAINLESS STEEL

SELF-ACTUATED PRESSURE REDUCING VALVE WITH SHOCK-ABSORBING PISTON

Features

Technologically advanced pressure reducing valve combined with condensate separator and steam trap provides accurate control and steam conditioning to maximize process system performance.

1. Space-saving unit simplifies system layout, piping and maintenance.
2. Self-aligning shock-absorbing spherical piston and advanced pilot regulator designs maintain secondary steam pressure accuracy, even during adverse process conditions.
3. Built-in cyclone separator, with condensate separation efficiency as high as 98%, and self-modulating free float steam trap provide dry, high-quality steam supply.
4. Major internal components made of stainless steel for long service life.
5. Large surface area integral screens for pilot valve and main valve extend trouble-free service.
6. Internal secondary pressure-sensing channel makes external sensing line unnecessary.
7. COS-16, sizes DN 65 and larger have a silencer for noise reduction.



Pressure Equipment Directive (PED)



This product fully conforms to the requirements of the Pressure Equipment Directive (PED, 2014/68/EU) and features CE marking where applicable.

Specifications

Model	COS-3			COS-16			
	Cast Iron (JIS FC250) (equiv. GG-25)	Ductile Cast Iron (GGG40.3)	Cast Stainl. Steel (A351 Gr.CF8) (equiv. 1.4312)	Cast Iron (JIS FC250) (equiv. GG-25)	Ductile Cast Iron (GGG40.3)	Cast Stainl. Steel (A351 Gr.CF8) (equiv. 1.4312)	
Body Material							
Connection	Screwed	Flanged ASME	Flanged DIN	Flanged DIN	Screwed	Flanged ASME	Flanged DIN
Size	3/4", 1"	DN 20, 25, 40, 50		1/2", 3/4", 1"	DN 15, 20, 25, 40, 50, 65*, 80*, 100		DN 15, 20, 25, 40, 50
Max. Operating Pressure (barg) PMO	3			13	16		
Max. Operating Temperature (°C) TMO	200	220		200	220		
Primary Pressure Range (barg)	1 – 3			2 – 13	2 – 16		
Adjustable Pressure Range (all conditions must be met)	0.1 – 0.5 barg			Within 10 – 84% of primary pressure but with a minimum pressure of 0.3 barg			
	–			Differential pressure between 0.7 – 8.5 bar			
Minimum Adjustable Flow Rate	5% of rated flow rate			5% of rated flow rate (For DN 65 – DN 100 : 10% of rated flow rate)			

* COS-16 flanged (DIN): cast steel DN 65, DN 80 available on request

1 bar = 0.1 MPa

PRESSURE SHELL DESIGN CONDITIONS (**NOT** OPERATING CONDITIONS):

Maximum Allowable Pressure (barg) PMA: 13 (FC250), 21 (GGG40.3, CF8)

Maximum Allowable Temperature (°C) TMA: 200 (FC250), 220 (GGG40.3, CF8)



To avoid abnormal operation, accidents or serious injury, DO NOT use this product outside of the specification range. Local regulations may restrict the use of this product to below the conditions quoted.

Configuration

No.	Description	Material	DIN*	ASTM/ AISI*	
①	Main Body	Ductile Cast Iron GGG40.3	0.7043	A395	
		Cast Stainless Steel A351 Gr.CF8	1.4312	—	
		Cast Iron FC250	0.6025	A126 Cl.B	
②	Trap Body	Same material as main body			
③	Trap Cover	Same material as main body			
④	Separator	Stainless Steel	—	—	
⑤	Float	Stainless Steel	—	—	
⑥	Float Cover	Same material as main body			
⑦	Trap Valve Seat	Stainless Steel	—	—	
⑧	Separator Screen	Stainless Steel	—	—	
⑨	Main Valve Seat	Stainless Steel	—	—	
⑩	Main Valve	Stainless Steel	—	—	
⑪	Main Valve Holder	Stainless Steel	—	—	
⑫	Piston	Stainless Steel	—	—	
⑬	Cylindre	Stainless Steel	—	—	
⑭	Pilot Screen	Stainless Steel	—	—	
⑮	Pilot Screen Holder	Cast Iron and Ductile Cast Iron Models	Carbon Steel S25C	1.1158	AISI1025
		Cast Stainless Steel Models	Stainless Steel SUS303	1.4305	AISI303
⑯	Pilot Body	Same material as main body			
⑰	Pilot Valve	Stainless Steel	—	—	
⑱	Pilot Valve Seat	Stainless Steel	—	—	
⑲	Diaphragm	Stainless Steel	—	—	
⑳	Diaphragm Support	Brass	—	—	
㉑	Spring Housing	Same material as main body			
㉒	Coil Spring	Carbon Steel	—	—	
㉓	Adjustment Screw	Cr-Mo Steel	—	—	
㉔	Spanner Cap	Cast Iron and Ductile Cast Iron Models	Die Cast Aluminium	—	—
		Cast Stainless Steel Models	Stainless Steel	—	—
㉕	Plug – Sensing Line Port	Cast Iron and Ductile Cast Iron Models	Carbon Steel SS400	1.0037	A6
		Cast Stainless Steel Models	Stainless Steel SUS304	1.4301	AISI304
㉖	Pilot Cover	Same material as main body			
㉗	Nameplate	Stainless Steel	—	—	
㉘	Silencer	Stainless Steel	—	—	

* Equivalent materials
Contact TLV for available replacement parts. All gaskets are PTFE.

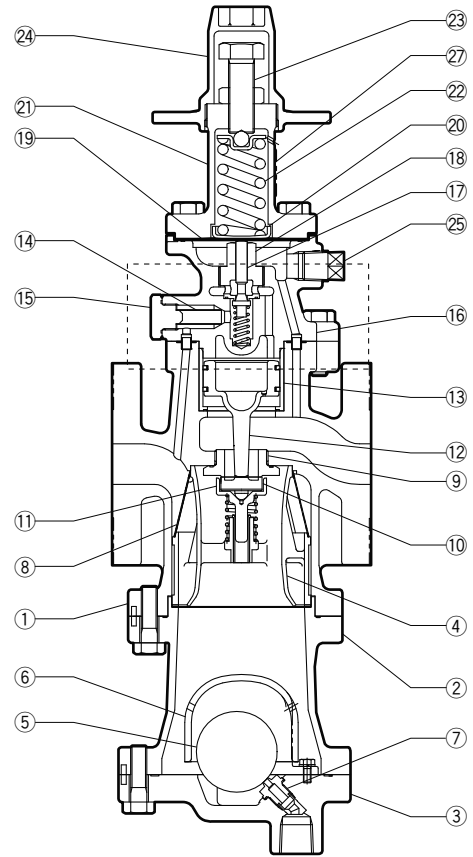

DN 65 - 100

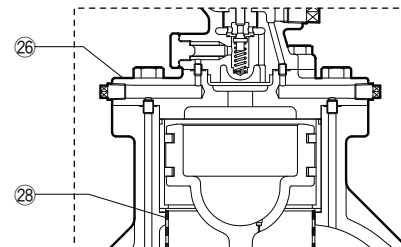

The parts configuration of sizes DN 65 - 100 differs slightly from that of sizes DN 15 - 50.

Capacity Table COS-3

With internal (factory standard) or external (option) secondary pressure-sensing channel or line (kg/h)

Primary Steam Press. (barg)	Secondary (Set) Steam Press. (barg)		Nominal Valve Size (DN)			
	Internal Channel	External Line (option)	20	25	40	50
1 to less than 2	*0.5	*0.5 - **0.1	120	180	750	950
	0.4	/	130	190	700	920
	0.3		135	195	680	900
	0.2		140	200	500	690
	**0.1		100	180	380	500
2 - 3	*0.5	*0.5 - **0.1	240	340	750	950
	0.4	/	230	330	700	920
	0.3		220	320	680	900
	0.2		160	250	500	690
	**0.1		100	180	380	500

* Maximum adjustable secondary pressure ** Minimum adjustable secondary pressure

1 bar = 0.1 MPa

Capacity Table COS-16

With internal (factory standard) or external (option) secondary pressure-sensing channel or line (kg/h)

Primary Steam Press. (barg)	Secondary (Set) Steam Press. (barg)		Nominal Valve Size (DN)							
	Internal Channel	External Line (option)	15	20	25	40	50	65	80	100
2	*1.3	*1.3	170	240	340	670	920	1460	2090	3150
	1.1	1.1	180	260	370	720	990	1570	2250	3400
	1	**0.3 – 1	185	270	380	730	1010	1610	2310	3480
	0.7		60	160	360	700	1000	1600	2300	3470
	**0.3		50	140	340	660	990	1590	2290	3460
3	*2.3	*2.3	190	280	400	710	1090	1740	2500	3760
	2	2	200	290	430	800	1240	1790	2820	4250
	1.5	**0.3 – 1.5	210	310	450	880	1370	2180	3120	4700
	1		80	190	400	840	1300	2080	2980	4480
	**0.3		50	140	340	740	1150	1830	2630	3950
4	*3.3	*3.3	200	290	410	800	1250	1980	2840	4280
	3	3	220	310	450	920	1420	2270	3250	4900
	2.5	2.5	230	320	480	1040	1610	2570	3690	5560
	2	**0.4 – 2	240	350	520	1130	1750	2790	3990	6020
	1		80	280	440	960	1490	2370	3390	5110
**0.4	60		150	390	850	1310	2090	3000	4510	
5	*4.2	*4.2	220	320	370	940	1460	2320	3330	5010
	4	4	240	340	470	1030	1590	2530	3630	5470
	3	3	260	380	590	1270	1980	3050	4510	6800
	2.5	**0.5 – 2.5	270	400	620	1350	2080	3320	4760	7170
	1.5		170	320	520	1120	1730	2760	3950	5950
**0.5	60		150	410	890	1380	2190	3140	4730	
6	*5	*5	250	350	520	1120	1740	2770	3970	5980
	4	4	280	410	660	1420	2210	3520	5040	7590
	3.5	3.5	290	440	690	1500	2330	3710	5320	8010
	3	**0.6 – 3	300	460	720	1560	2420	3860	5530	8330
	1.5		170	320	480	1030	1600	2550	3800	5500
**0.6	60		150	420	920	1420	2260	3250	4890	
7	*5.8	*5.8	250	370	600	1300	2020	3220	4610	6940
	5	5	290	450	720	1560	2420	3850	5520	8320
	4	4	330	500	800	1720	2670	4260	6110	9200
	3.5	**0.7 – 3.5	350	510	820	1780	2750	4390	6290	9480
	2		200	380	610	1310	2040	3250	4660	7010
**0.7	70		230	430	930	1450	2310	3310	4980	
8	*6.7	*6.7	280	410	670	1440	2230	3550	5100	7620
	6	6	300	480	780	1680	2610	4160	5970	8980
	5	5	340	540	870	1890	2930	4670	6690	10100
	4	**0.8 – 4	400	570	920	1990	3090	4920	7060	10600
	2		200	380	610	1310	2040	3250	4660	7010
**0.8	70		160	410	900	1390	2220	3180	4780	
10	*8.4	*8.4	310	500	810	1750	2720	4330	6210	9360
	7	7	390	630	1010	2180	3380	5390	7730	11600
	6	6	470	670	1080	2340	3620	5780	8280	12500
	5	**1.5 – 5	500	700	1120	2420	3750	5990	8580	12900
	3		300	460	740	1600	2480	3950	5790	8520
**1.5	170		320	480	970	1510	2390	3430	5170	
12	*10	*10	350	610	980	2110	3270	5220	7480	11300
	8	8	500	760	1230	2650	4110	6560	9400	14200
	7	7	570	800	1290	2780	4310	6870	9850	14800
	6	**3.5 – 6	600	820	1320	2850	4420	7050	10100	15200
	5		500	680	1090	2370	3670	5850	8380	12600
**3.5	360		550	890	1930	2980	4760	6820	10300	
13	*10.9	10.9	360	650	1040	2250	3490	5560	7960	12000
	10	10	410	740	1190	2560	3970	6330	9080	13700
	8	8	470	850	1360	2950	4570	7290	10500	15700
	6.5	**4.5 – 6.5	480	880	1410	3060	4740	7550	10800	16300
	5.5		400	730	1180	2550	3950	6290	9010	13600
**4.5	320		580	940	2020	3140	5000	7170	10800	
14	*11.7	*11.7	410	700	1120	2430	3760	6000	8590	12400
	10	10	540	840	1360	2940	4550	7260	10400	15600
	8	8	670	980	1490	3220	4990	7950	11400	17200
	7	**5.5 – 7	730	1050	1520	3280	5090	8110	11600	17500
	6		600	840	1240	2690	4170	6650	9530	14300
**5.5	550		770	1130	2450	3790	6040	8660	13000	
16	*13.4	*13.4	470	790	1270	2740	4250	6770	9710	14600
	10	10	730	1100	1650	3560	5520	8800	12600	19000
	9	9	790	1200	1750	3650	5660	9030	12900	19500
	8	**7.5 – 8	880	1300	2000	3710	5750	9170	13100	19800
	**7.5		820	1250	1800	3400	5260	8390	12000	18100

* Maximum adjustable secondary pressure ** Minimum adjustable secondary pressure

1 bar = 0.1 MPa

Cv & Kvs Values

	Nominal Valve Size (DN)							
	15*	20	25	40	50	65*	80*	100*
Kvs (DIN)	3.3	5.9	9.5	20.6	31.9	50.8	72.9	110
Cv (UK)	3.2	5.7	9.2	20.0	31.0	49.4	70.8	107
Cv (US)	3.8	6.9	11.1	24.0	37.2	59.3	85.0	128

* Only COS-16



The Cv & Kvs values shown are for the valve in the full fail open position. These values are not to be used for COS sizing, and instead may be used as one of the factors in calculations for safety valve selection.

Dimensions

• COS-3 / COS-16

Screwed

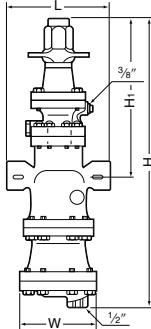

Flanged

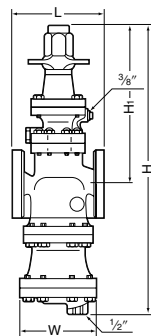

Sizes 1/2" - 1" and DN 15 - 25 shown. Configuration of larger sizes differs slightly.

COS-3 / COS-16 Screwed* (mm)

Size	L	H	H ₁	W	Weight (kg)
1/2"***	175	495	285	105	13
3/4"					
1"	190	522	282	150	17

* BSP DIN 2999, other standards available
 *** COS-16 only

COS-3 / COS-16 Flanged (mm)

DN	L					H	H ₁	W	Weight* (kg)
	DIN 2501	ASME Class							
	PN25/40	125FF	(150RF)	250RF	(300RF)				
(15)**	150	-	170	-	170	495	285	105	15
(20)	150	-	182	-	182				
25	160	176	188	188	192	522	282	150	20
40	200	209	220	222	224	572	302	165	27
50	230	255	255	260	261	635	315	195	44
65**	370	362	372	377	378	870	410	280	96
80**	374	365	374	383	384				97
100**	434	434	434	450	450				1028

() No ASME standard exists for cast iron; machined to fit steel flanges
 Class 125 FF can connect to 150 RF, 250 RF can connect to 300 RF
 Other standards available, but length and weight may vary
 * Weight is for PN 25/40 (ductile cast iron)
 ** COS-16 only
 Flange to flange dimension of DN 15 and DN 65-100, not according to DIN standard, due to size of separator and steam trap.

Trap Discharge Capacity

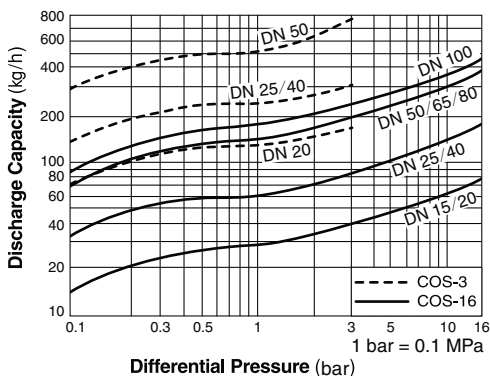

- Note: 1. The discharge capacity is the maximum continuous condensate discharge 6 °C below saturated steam temperature.
- 2. The differential pressure is the difference between the COS inlet and its trap outlet pressure.

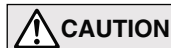

DO NOT use this product under conditions that exceed maximum differential pressure, as condensate backup will occur!

Manufacturer
TLV CO., LTD.
 Kakogawa, Japan
 is approved by LRQA Ltd. to ISO 9001/14001

