



**PACIFIC VALVES**

**brands you trust.**

TECHNICAL DATASHEET  
**PACIFIC VALVES® - Pressure Seal Valves**

**CRANE®**

[www.cranecpe.com](http://www.cranecpe.com)



# Materials Globe Stop & Stop-Check Valves

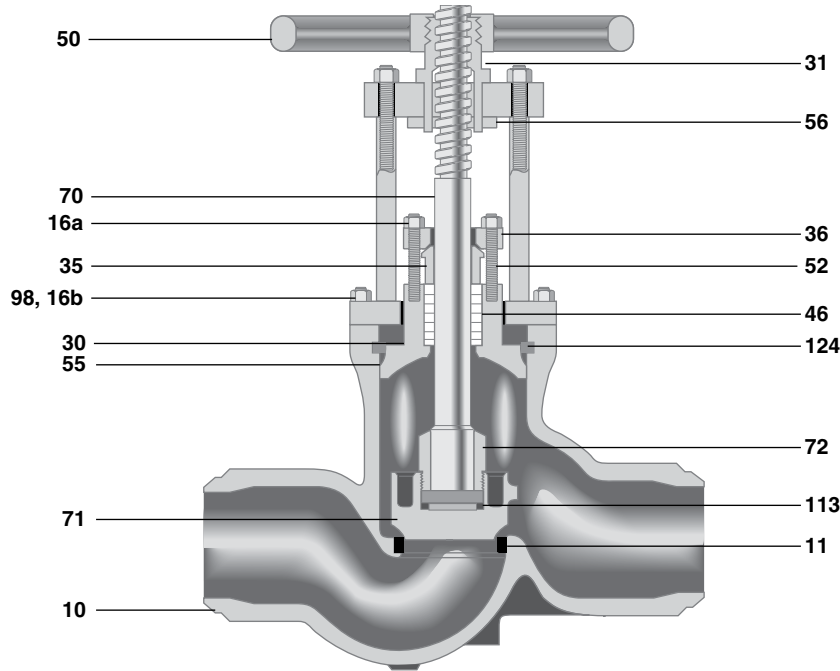

NO	PART NAME	CARBON STEEL	1¼ CHROME	2½ CHROME	9 Cr-1Mo-V	316 STAINLESS
50	HANDWHEEL	ASTM A47 GR 32510	ASTM A47 GR 32510	ASTM A47 GR 32510	ASTM A47 GR 32510	ASTM A47 GR 32510
31	YOKE SLEEVE	ASTM A148 ALLOY 955	ASTM A148 ALLOY 955	ASTM A148 ALLOY 955	ASTM A148 ALLOY 955	ASTM A148 ALLOY 955
20	BEARINGS	MFG STD	MFG STD	MFG STD	MFG STD	MFG STD
70	STEM	13% CHROME	13% CHROME	13% CHROME	13% CHROME	ASTM A705 GR 630
36	GLAND FLANGE	CARBON STEEL	CARBON STEEL	CARBON STEEL	CARBON STEEL	CARBON STEEL
35	GLAND	12% CHROME	12% CHROME	12% CHROME	12% CHROME	300 SERIES SST
46	PACKING	GRAPHITIC*	GRAPHITIC**	GRAPHITIC**	GRAPHITIC**	GRAPHITIC**
30	BONNET	CARBON STEEL	ASTM A182 GR, F22	ASTM A182 GR, F22	ASTM A182 GR, F91	ASTM A182 GR, F316
		W/CO-CR	W/CO-CR	W/CO-CR	W/CO-CR	W/CO-CR
124	SEGMENT RING	AISI 4340 OR 4140	AISI 4340 OR 4140	AISI 4340 OR 4140	AISI 4340 OR 4140	AISI 4340 OR 4140
73	THRUST RING <sup>3</sup>	AISI 4340 OR 4140	AISI 4340 OR 4140	AISI 4340 OR 4140	AISI 4340 OR 4140	AISI 4340 OR 4140
55	GASKET	GRAPHITE/SS CAPS OR MILD STEEL SILVER PLATED***	GRAPHITE/SS CAPS OR MILD STEEL SILVER PLATED***	GRAPHITE/SS CAPS OR MILD STEEL SILVER PLATED***	GRAPHITE/SS CAPS OR MILD STEEL SILVER PLATED***	GRAPHITE/SS CAPS OR MILD STEEL SILVER PLATED***
72	DISC NUT	CARBON STEEL	316 SS OR 2¼ CR	316 SS OR 2¼ CR	316 SS	316L SS
71	DISC	CARBON STEEL	316 SS OR 2¼ CR	316 SS OR 2¼ CR	316 SS	316L SS
11	SEAT RING	W/CO-CR OVERLAY	W/CO-CR OVERLAY	W/CO-CR OVERLAY	W/CO-CR OVERLAY	W/CO-CR OVERLAY
10	BODY <sup>1</sup>	CARBON STEEL W/CO-CR	316 SS OR 2¼ CR W/CO-CR	316 SS OR 2¼ CR W/CO-CR	ALLOY 91 W/CO-CR OVERLAY	316L SS
98	BONNET STUDS	ASTM A216 GR WCB OR WCC <sup>2</sup>	ASTM A217 GR WC6	ASTM A217 GR WC9	ASTM A217 GR C12-A	ASTM A351 GR CF8M
16b	STUD NUTS	ASTM A193 GR B7	ASTM A193 GR B7	ASTM A193 GR B7	ASTM A193 GR B7	ASTM A193 GR B7
52	GLAND STUD	ASTM A194 GR 2H	ASTM A194 GR 2H	ASTM A194 GR 2H	ASTM A194 GR 2H	ASTM A194 GR 2H
16a	GLAND NUTS	CARBON STEEL	CARBON STEEL	CARBON STEEL	CARBON STEEL	CARBON STEEL
113	DISC THRUST PLATE	ASTM A194 GR 2H	ASTM A194 GR 2H	ASTM A194 GR 2H	ASTM A194 GR 2H	ASTM A194 GR 2H
16c	NUTS	316 SS/PLATED	316 SS/PLATED	316 SS/PLATED	316 SS/PLATED	316 SS/PLATED16c
59	GREASE FITTING	ASTM A194 GR 2H	ASTM A194 GR 2H	ASTM A194 GR 2H	ASTM A194 GR 2H	ASTM A194 GR 2H
98	THREADED COL.	MFG STAD.	MFG STAD.	MFG STAD.	MFG STAD.	MFGSTAD
98a	BOLTING	ASTM A193 GR B7	ASTM A193 GR B7	ASTM A193 GR B7	ASTM A193 GR B7	ASTM A193 GR B7
98b	DRAW BOLTING	ASTM A193 GR B7	ASTM A193 GR B7	ASTM A193 GR B7	ASTM A193 GR B7	ASTM A193 GR B7
54	HANDWHEEL NUT	ASTM A193 GR B7	ASTM A193 GR B7	ASTM A193 GR B7	ASTM A193 GR B7	ASTM A193 GR B7
128	TUBULAR COL.	CARBON STEEL	CARBON STEEL	CARBON STEEL	CARBON STEEL	CARBON STEEL
56	JAM NUT	CARBON STEEL	CARBON STEEL	CARBON STEEL	CARBON STEEL	CARBON STEEL

Pacific Valves® reserves the right to change or modify product design or construction without prior notice and without incurring any obligation to make such changes and modifications on products previously or subsequently sold.

**NOTES:**

1. A 309 SS inlay is furnished in the gasket area of the body on ASME class 2500 valves. For this option on other pressure classes, specify special features suffix H.
2. WCC valve bonnet and internals will be manufactured with 300 series stainless or 2¼ CR material.
3. Thrust ring comes standard on 12" and larger ASME class 1500. All sizes of ASME class 2500.

\*Special high temperature packing is recommended for services over 850°F. Consult factory when ordering.

\*\*High temperature packing is standard.

\*\*\*Graphite Pressure Seal Bonnet Gasket standard. Mild Steel Silver Plated available on request.



# Dimensions Globe Stop & Stop-Check Valves • ASME Class 900

## Globe Stop Valves

Fig. No. **56009-7-WE\*** Butt Weld Ends  
 Fig. No. **56009-7** Flanged, Raised Face  
 Fig. No. **56009-7-RJ** Flanged, Ring Joint

## Globe Stop-Check Valves

Fig. No. **56509-7-WE\*** Butt Weld Ends  
 Fig. No. **56509-7** Flanged, Raised Face  
 Fig. No. **56509-7-RJ** Flanged, Ring Joint

Dim	Description		VALVE SIZES (inches)								
			2	2.5	3	4	6	8	10	12	14
A	End-to-End Weld Ends	in.	12	12	12	14	20	26	31	36	39
		mm	304	304	304	355	508	660	787	914	990
A <sub>1</sub>	Face-to-Face Flanged Ends	in.	N/A	N/A	15	18	24	29	33	38	40.5
		mm	N/A	N/A	381	457	609	736	838	965	1028
A <sub>2</sub>	Face-to-Face RTJ	in.	N/A	N/A	15.13	18.13	24.13	29.13	33.13	38.13	40.88
		mm	N/A	N/A	384	460	612	739	841	968	1039
K	Center-to-Top Open	in.	18	18	18	23	33	39	46	52	60
		mm	457	457	457	584	825	990	1186	1320	1524
M	Handwheel Dia.	in.	16	16	16	16	28	28	36	36	36
		mm	406	406	406	406	711	711	914	914	914
**	Weight Weld Ends	lbs	90	90	90	198	576	965	1603	2272	3384
		kg	41	41	41	90	261	437	727	1030	1534
**	Weight Flanged Ends	lbs	N/A	N/A	150	275	765	1325	2050	2920	4430
		kg	N/A	N/A	68	124	346	600	929	1324	2009

**NOTE:**

1. Integral body seat on 2" through 4" size.

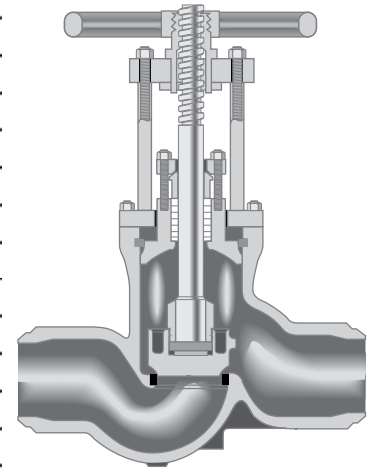

## VENTURI GLOBE STOP AND STOP-CHECK VALVES

**Globe Stop Valves** Fig. No. **56009-7-WE\*** Butt Weld Ends

**Globe Stop-Check Valves** Fig. No. **56509-7-WE\*** Butt Weld Ends

Dim	Description		VALVE SIZES (inches)				
			8x6x8	10x8x10	12x10x12	14x12x14	16x14x16
A	End-to-End	in.	24	29	33	38	40.5
		mm	609	736	838	965	1028
K	Center-to-Top Open	in.	33	39	46	52	60
		mm	825	990	1168	1320	1524
M	Handwheel Dia.	in.	28	28	36	36	36
		mm	711	711	914	914	914
**	Weight	lbs	580	979	1628	2340	3424
		kg	263	444	738	1061	1553

**General Notes:**

- Dimensions, weights, and other engineering data are subject to change or modification. This data is not to be used for construction unless confirmed by Pacific Valves®.
- For best performance, size for full open operation. See Flow Calculations in the Technical Data Section.  
 \* Specify pipe schedule.  
 \*\*Weight includes standard bevel gear where applicable.
- Related data available in Technical Data, Actuators, and Accessories sections.

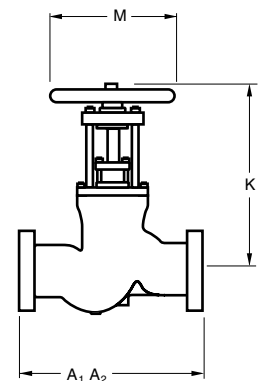
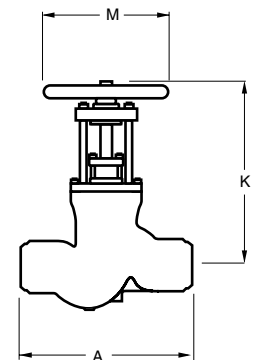



# Dimensions Globe Stop & Stop-Check Valves • ASME Class 1500

## Globe Stop Valves

- Fig. No. **56015-7-WE\*** Butt Weld Ends
- Fig. No. **56015-7** Flanged, Raised Face
- Fig. No. **56015-7-RJ** Flanged, Ring Joint

## Globe Stop-Check Valves

- Fig. No. **56515-7-WE\*** Butt Weld Ends
- Fig. No. **56515-7** Flanged, Raised Face
- Fig. No. **56515-7-RJ** Flanged, Ring Joint

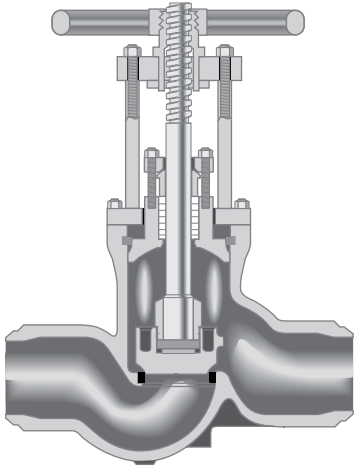

Dim	Description		VALVE SIZES (inches)							
			2	2.5	3	4	6	8	10	12
A	End-to-End Weld Ends	in.	14.5	16.5	18.5	21.5	27.75	32.75	39	44.5
		mm	368	419	469	546	704	831	990	1130
A <sub>1</sub>	Face-to-Face Flanged Ends	in.	16.5	16.5	18.5	21.5	27.75	32.75	39	44.5
		mm	419	419	469	546	704	831	990	1130
A <sub>2</sub>	Face-to-Face RTJ	in.	16.63	16.63	18.63	21.63	28	33.13	39.38	45.13
		mm	422	422	473	549	711	841	1000	1146
K	Center-to-Top Open	in.	19	19	23	27	37	47	50	57
		mm	482	482	577	685	933	1193	1270	1447
M	Handwheel Dia.	in.	16	16	16	16	28	36	36	42
		mm	406	406	406	406	711	914	914	1066
**	Weight Weld Ends	lbs	105	105	175	333	810	1381	2565	4046
		kg	47	47	79	151	367	626	1163	1835
**	Weight Flanged Ends	lbs	165	165	255	460	1110	1880	3380	5270
		kg	75	75	115	208	503	852	1533	2390

**NOTE:**

1. Integral body seat on 2" through 4" size.

## VENTURI GLOBE STOP AND STOP-CHECK VALVES

Globe Stop Valves Fig. No. **56015-7-WE\*** Butt Weld Ends

Globe Stop-Check Valves Fig No. **56515-7-WE\*** Butt Weld Ends

Dim	Description		VALVE SIZES (inches)			
			8x6x8	10x8x10	12x10x12	14x12x14
A	End-to-End	in.	27.75	32.75	39	44.5
		mm	705	831	990	1130
K	Center-to-Top Open	in.	37	47	50	57
		mm	933	1193	1270	1447
M	Handwheel Dia.	in.	28	36	36	42
		mm	711	914	914	1066
**	Weight	lbs	816	1396	2595	4082
		kg	370	633	1177	1851

**General Notes:**

1. Dimensions, weights, and other engineering data are subject to change or modification. This data is not to be used for construction unless confirmed by Pacific Valves®.
2. For best performance, size for full open operation. See Flow Calculations in the Technical Data Section.
  - \* Specify pipe schedule.
  - \*\*Weight includes standard bevel gear where applicable.
3. Related data available in Technical Data, Actuators, and Accessories sections.

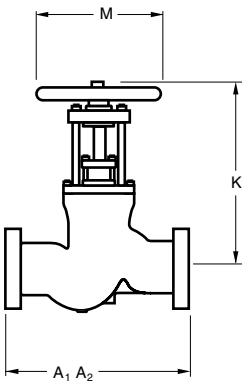
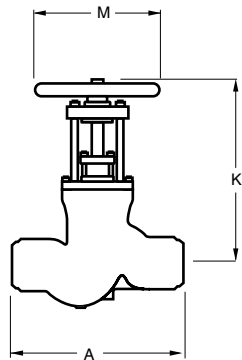



# Dimensions Globe Stop & Stop-Check Valves • ASME Class 2500

## Globe Stop Valves

Fig. No. **56025H-7-WE\*** Butt Weld Ends  
 Fig. No. **56025H-7** Flanged, Raised Face  
 Fig. No. **56025H-7-RJ** Flanged, Ring Joint

## Globe Stop-Check Valves

Fig. No. **56525H-7-WE\*** Butt Weld Ends  
 Fig. No. **56525H-7** Flanged Raised Face  
 Fig. No. **56525H-7-RJ** Flanged, Ring Joint

Dim	Description		VALVE SIZES (inches)							
			2	2.5	3	4	6	8	10	12
A	End-to-End Weld Ends	in.	13	13	15	18	24	29	33	38
		mm	330	330	381	457	609	736	838	965
A <sub>1</sub>	Face-to-Face Flanged Ends	in.	20	20	22.75	26.5	36	40.25	50	56
		mm	508	508	578	673	914	1022	1270	1422
A <sub>2</sub>	Face-to-Face RTJ	in.	20.25	20.25	23	26.88	36.5	40.88	50.88	56.88
		mm	514	514	584	683	927	1039	1293	1445
K	Center-to-Top Open	in.	20	20	24	27	38	47	56	60
		mm	495	495	603	685	971	1200	1416	1524
M	Handwheel Dia.	in.	16	16	16	16	28	36	42	42
		mm	406	406	406	406	711	914	1066	1066
**	Weight Weld Ends	lbs	165	165	253	310	1013	1693	2911	4200
		kg	74	74	114	140	459	767	1320	1905
**	Weight Flanged Ends	lbs	260	260	430	575	1700	2730	4900	7300
		kg	117	117	195	260	770	1238	2222	3310

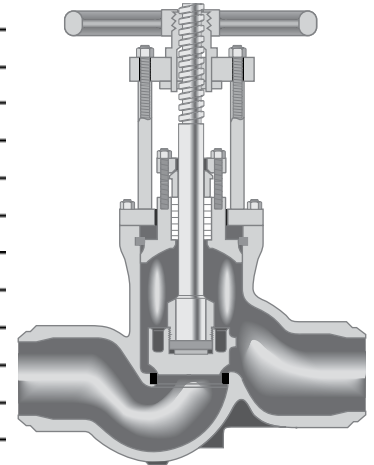

**NOTE:**

1. Integral body seat on 2" through 3" size.

## VENTURI GLOBE STOP AND STOP-CHECK VALVES

**Globe Stop Valves** Fig. No. **56025H-7-WE\*** Butt Weld Ends

**Globe Stop-Check Valves** Fig. No. **56525H-7-WE\*** Butt Weld Ends

Dim	Description		VALVE SIZES (inches)			
			8x6x8	10x8x10	12x10x12	14x12x14
A	End-to-End	in.	31.25	36	40.25	50
		mm	914	1092	1244	1625
K	Center-to-Top Open	in.	38	47	56	60
		mm	971	1200	1416	1524
M	Handwheel Dia.	in.	28	36	42	42
		mm	711	914	1066	1066
**	Weight	lbs	1063	1828	3125	4460
		kg	482	829	1417	2023

**NOTES:**

1. Impact Handwheel standard—all sizes.

**General Notes:**

- Dimensions, weights, and other engineering data are subject to change or modification. This data is not to be used for construction unless confirmed by Pacific Valves®.
- For best performance, size for full open operation. See Flow Calculations in the Technical Data Section.  
 \* Specify pipe schedule.  
 \*\*Weight includes standard bevel gear where applicable.
- Related data available in Technical Data, Actuators, and Accessories sections.

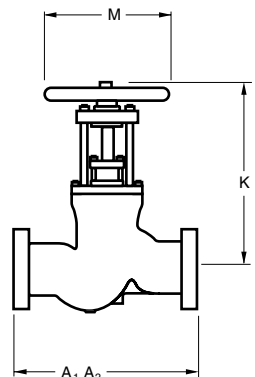
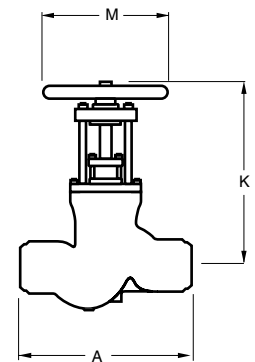



# Pressure Seal Figure Number System

1 2 - 4 5 6 7 8 - 10 11 12 13 - 15 - 17 - 19 20 21 - 23 24 25 26 27 28 29 30

### 1 - 2 = Size of Connection

2H = 2 1/2" Valve  
03 = 3" Valve

### 4 - 6 = Valve Type

554 = Parallel Disc  
555 = Flex Wedge  
560 = T-Globe Stop  
565 = T-Globe Stop Check (non-return)  
580 = Swing Check  
586 = Lift Check - Globe  
588 = Tilting Disc Check  
590 = Y Globe Stop Valve  
595 = Y Globe Stop Check  
596 = Y Globe Life Check

### 7 - 8 = Pressure Class

06 = 600  
6C = 600 Intermediate Class  
(see sales order notes)  
09 = 900  
9C = 900 Intermediate Class  
(see sales order notes)  
15 = 1500  
1C = 1500 Intermediate Class  
(see sales order notes)  
25 = 2500  
2C = 2500 Intermediate Class  
(see sales order notes)  
45 = 4500

### 10 = Valve Port Size

\*S = Standard port  
R = Reduced port  
E = Expanded port

### 11 - 12 = By Pass, Drain & Bleed Arrangements

\* NN = N.A.  
EA = Equalizing Line from body neck to A  
EB = Equalizing Line from body neck to B  
KW = Bonnet Vent in upstream side of wedge  
J1 = Single valve bypass from A to B  
J2 = Double valve bypass from A to B  
J3 = Triple valve bypass from A to B and body neck  
JA = Single valve equalizing line from body neck to A  
JB = Single valve equalizing line from body neck to B  
VV = 6" socket weld nipples with globe style drain valves at locations C&D  
PP = 6" socket weld nipples capped at locations C&D  
V? = 6" socket weld nipple with globe style drain valve at location? (A-G)  
P? = 6" socket weld nipple capped at location? (A-G)

### 13 = Custom Feature

\*N = N.A.  
X = See sales order notes

### 15 = Special Processing

\*S = No special processing  
Z = See sales order notes

### 17 = Body Material

1 = WCB  
2 = WCC  
4 = C12A  
5 = C5  
6 = WCG  
9 = WCG

### 19 = Customer Pipe Schedule

A = 10  
B = 20  
C = 30  
D = 40  
E = STD  
F = 60  
G = 80  
H = XS  
J = 100  
K = 120  
L = 140  
M = 160  
N = XXS  
X = Custom (see sales order notes)

### 20 - 21 = Valve Weld End Prep Figure (per ASME B16.25)

Pipe wall thickness .1875" to .88"  
\*2B = For use with no backing ring or split rectangular backing ring  
2C = For use with continuous rectangular backing ring  
2D = For use with continuous tapered backing ring

Pipe wall thickness greater than .88"  
\*3B = For use with no backing ring or split rectangular backing ring  
3C = For use with continuous rectangular backing ring  
3D = For use with continuous tapered backing ring

For use with GTAW root pass or consumable insert ring  
5B = Pipe wall thickness from .38" to 1.0"  
6B = Pipe wall thickness over 1.0"

XX= Custom weld ends (see sales order notes)  
RF= Raised face flanged end connections

### 23 = Manual Operation

N = N.A.  
H = Handwheel  
L = Handwheel with locking device (closed)  
R = Handwheel with locking device (open)  
J = Handwheel with chain  
G = Manual Bevel Gear Operator  
C = Manual Bevel Gear Operator with Chainwheel  
A = Manual Bevel Gear with Air Wrench  
P = Manual Bevel Gear with position indicator  
M = Manual Bevel Gear Operator with locking device (closed)  
R = Manual Bevel Gear Operator with locking device (open)  
B = Hammerblow Handwheel

### 24 = Valve Actuator

N = N.A.  
E = Direct mount Electric Motor Operator  
T = Direct mount Electric Motor Operator with thermal compensating device  
F = Electric Motor Operator with Bevel Gear  
P = Pneumatic Operator  
H = Hydraulic Operator  
M = Operator mounted by customer

### 25 = Gear & Actuator Mounting Dimensions (per MSS SP-102)

N = N.A.      5 = FA25  
1 = FA7        6 = FA30  
2 = FA10      7 = FA35  
3 = FA14      8 = FA40  
4 = FA16      9 = Other

\* Denotes Standard Offering





## Crane ChemPharma & Energy

Crane Energy Headquarters  
4526 Research Forest Drive, Suite 400  
The Woodlands, Texas 77381 U.S.A  
Tel: +1 936 271 6500  
Fax +1 936 271 6510

[www.cranecpe.com](http://www.cranecpe.com)



Pacific Valves Customer Service  
88/1A Vadugapatti Villiage  
Viralimamiai 621316 India  
Tel.: +91-4339-220252  
Fax.: +91-4339-220013

Pacific Valves Customer Service  
3201 Walnut Avenue  
Signal Hill, CA 90755 U.S.A  
Tel: +1 562 426 2531  
Fax +1 562 595 9717

### brands you trust.



COMPAC-NOZ®



DEPA®

ELRO®

DUO-CHEK®



NOZ-CHEK®



RESISTOFLEX®



Saunders®  
*the science inside*

STOCKHAM®



UNI-CHEK®

w.ta®

XOMOX®

Crane Co., and its subsidiaries cannot accept responsibility for possible errors in catalogues, brochures, other printed materials, and website information. Crane Co. reserves the right to alter its products without notice, including products already on order provided that such alteration can be made without changes being necessary in specifications already agreed. All trademarks in this material are property of the Crane Co. or its subsidiaries. The Crane and Crane brands logotype, in alphabetical order, (ALOYCO®, CENTER LINE®, COMPAC-NOZ®, CRANE®, DEPA®, DUO-CHEK®, ELRO®, FLOWSEAL®, JENKINS®, KROMBACH®, NOZ-CHEK®, PACIFIC VALVES®, RESISTOFLEX®, REVO®, SAUNDERS®, STOCKHAM®, TRIANGLE®, UNI-CHEK®, WTA®, and XOMOX®) are registered trademarks of Crane Co. All rights reserved.