

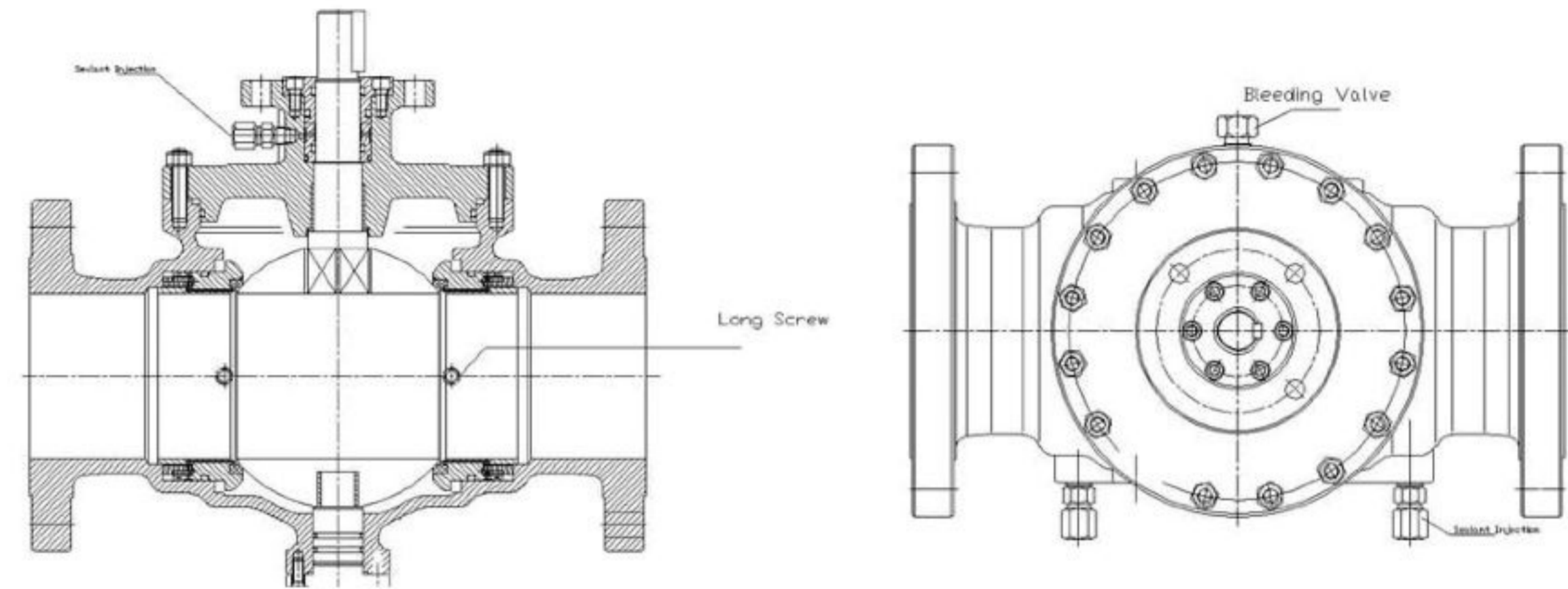

HAWKS
PRODUCT CATALOGUE

Trunnion Mounted Ball Valve-TOP ENTRY



Design Feature

- Cast Steel Uni-Body
- Forged Steel welded body(Fully Welded)
- Fire safe design
- Double block & bleed
- Emergency sealant injection
- Cavity pressure self relief
- Blowout-proof stem
- Antic-static
- Optional double piston design

Product Range

	Cast Steel Uni-Body
Size	2"~24"(DN50~DN600)
Rating	150~2500LB (PN16 ~ PN250)
Body material	Carbon Steel, Stainless Steel
Trim	A105 + ENP, 13Cr, F304, F316
Operation	Lever, Gear, Motor