

AUTHORIZED COMPANY



CASTING VALVE

GATE VALVE • GLOBE VALVE • SWICH • BALL • PLUG • VALVE
CARBON & ALLOY STEEL STAINLESS STEEL VALVE



Hawks Eng'r Co., Ltd.



Hawks ENG'R Co., Ltd.

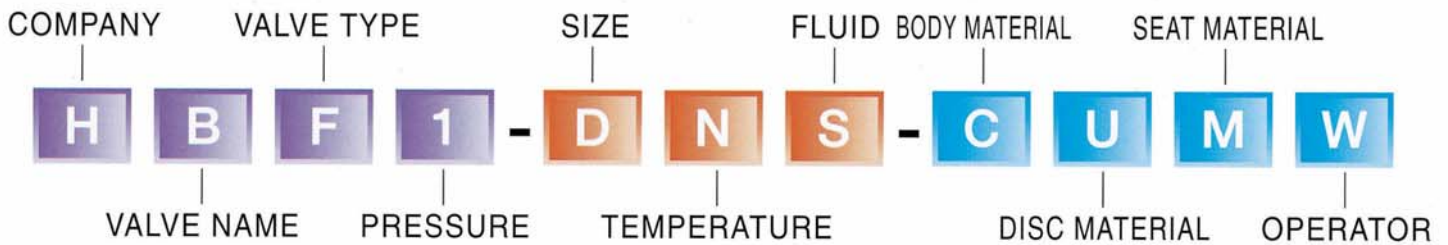

H-COMPANY
HAWKS Co., Ltd.

B-VALVE NAME
B/Butterfly, GA/Gate,
GL/Globe, BA/Ball,
CH/Check.

F-VALVE TYPE
F/Flange, L/Lugged,
W/Wafer, B/Butt
Weld, S/Special

1-PRESSURE
1/10k(150#), 2/20k(300#),
3/30k(450#), 4/40k(600#),
6/60k(900#), 9/90k(1500#), etc...

D-SIZE
Standard -- 2"~24"
A/2", B/2.5", C/3", D/4", E/5", F/6",
G/8", H/10", J/12", K/14", L/16", M/18",
N/20", O/24", P/28", Q/32", R/36", S/40",
T/44", U/48". etc ... Others is a
marking of additionally
dependable by the buyer.

N-TEMPERATURE
1/100°C, 2/200°C, 3/300°C,
5/500°C, 7/700°C, 9/900°C
N/20 (normal temp')
Low temp is a marking of
additionally dependable by
the buyer.

S-FLUID
S/Steam, W/Water,
O/Oil, G/Gas,
B/Brine, C/Chemical

C-BODY MATERIAL
D : CARBON STEEL
E : HIGH TEMP ALLOY STEEL
F : LOW TEMP ALLOY STEEL
S : STAINLEN STEEL
Others is a marking of
additionally dependable
by the buyer.

DISC MATERIAL
S : 304, 316SS
F : A217-CA15
W : A216-WCB
Others is a marking of
additionally dependable
by the buyer.

SEAT MATERIAL
M : 304SS, 316SS
H : HF STELLITE
F : FULL STELLITE
Others is a marking of
additionally dependable
by the buyer.

W-OPERATOR
L/Hand wheel
W/Worm gear
P/Pneumatic actuator
H/Hydraulic actuator
E/Electric actuator

Floating ball valve

Application

Floating ball valves are suitable for use on various kinds of pipelines of Class 150 to Class 1500, PN16 to Pn100, and JIS 10K to JIS 20K to turn on or off the pipeline medium, of which the operation types include manual, worm gear and pneumatic or electric actuators.

Construction and features of floating ball valve

Reliable seat seal

The structure design of elastic sealing ring has been adopted for floating ball valves. This seat design features a bigger sealing pressure ratio between the ring surface and the ball when medium pressure gets lower, where the contacting area is smaller. Thus, the reliable seal is ensured. When the medium pressure gets higher, the contacting area between seat ring and ball becomes bigger as the sealing ring transforms elastically to undertake the bigger force pushed by the medium without any damage.

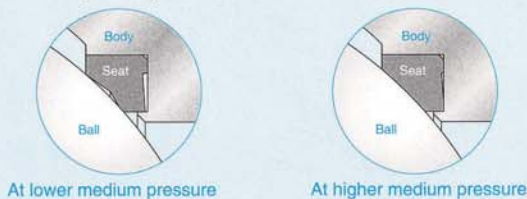

Fire safe design

With the valve heated in a fire application, the non-metal material parts such as seat sealing ring of PTFE, stem back seat gasket, gland packing, and the sealing gasket between body and bonnet might disintegrate or be damaged due to high temperature. Hawks's specially designed structure of auxiliary metal to metal seal is provided to effectively prevent both internal and external leakage of the valve. As required by customers, Hawks's floating ball valves with design can meet the requirement of API 607, API 6FA, BS 6755.

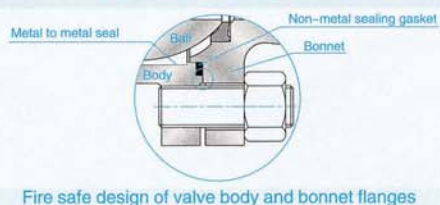
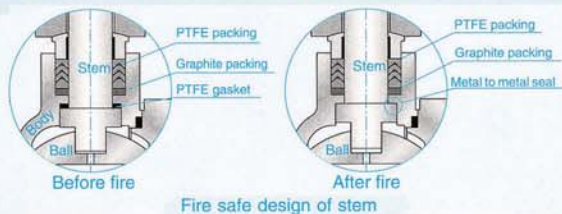
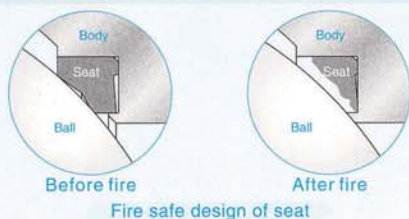

Reliable stem seal

The blow-out proof design has been adopted for the stem to ensure that even if the pressure in the body cavity is risen accidentally and the packing flange becomes invalid, the stem may not be blown out by medium. The stem features the design with a backseat, being assembled from underneath. The sealing force against the backseat gets higher as the medium pressure becomes higher. So the reliable seal of the stem can be assured under variable medium pressure.

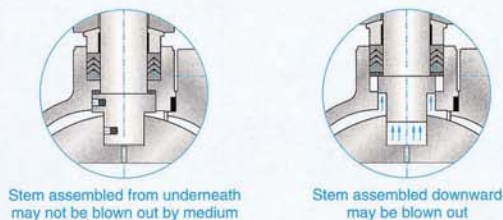

V type packing structure has been employed to effectively transform the pushing force of the gland flange and the medium pressure into the sealing force against the stem.

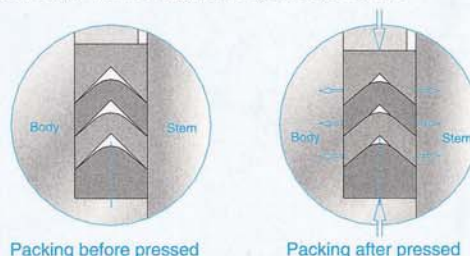

The traditional packing flange design has been improved to be of two piece structure, i.e., being as a gland flange and gland, the latter contacts the gland flange with spherical surface. Thus, the gland remains vertical always, and is lined internally with a PTFE bush to prevent the galling against and friction between the stem, which can also reduce the operation torque of the valve.

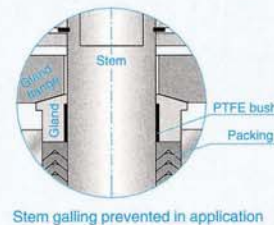

Based on customers' requirement, a packing tightening design may be employed to obtain more reliable stem packing seal, which is loaded by bevellingspring.

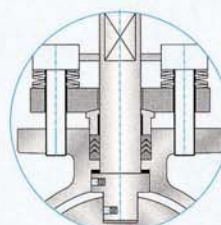

Floating ball valve

Anti-static feature

The traditional packing flange design has been improved to be of two piece structure, i.e., being as a packing flange plate and a follower, the latter contacts the flange plate with spherical surface. Thus, the follower remains vertical always, and is lined internally with a PTFE bush to prevent the galling against and friction between the stem, which can also reduce the operation torque of the valve.

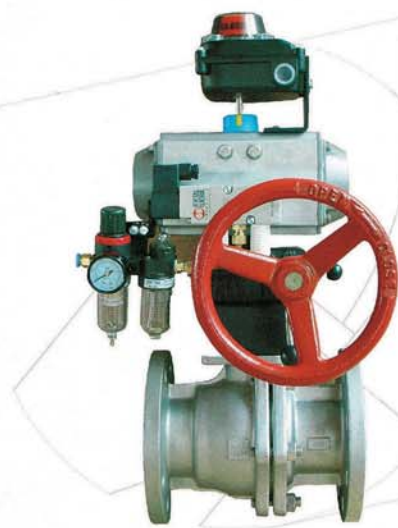
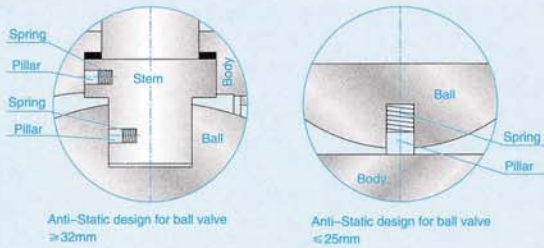

Wrong operation prevention

To prevent the ball valve from wrong operation, the key lock with 90° of open and close positioning pad has been provided, which can be lockable as required. At the stem head, where the lever fixes, a flat is so designed that the valve opens with the lever in parallel to piping, and with the lever right-angled to the piping, the valve is closed. So, it is ensured that the valve indicator of open and close can never make mistake.

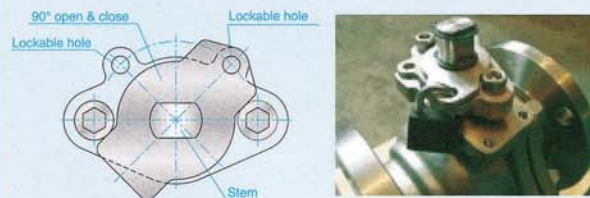

Mounting pad provided

Hawks company has provided for floating ball valve with a mounting pad, through which it is easy to fix the actuators, such as worm gear, pneumatic and electric actuators.



Floating ball valve

Typical drawing of floating ball valve and parts composition

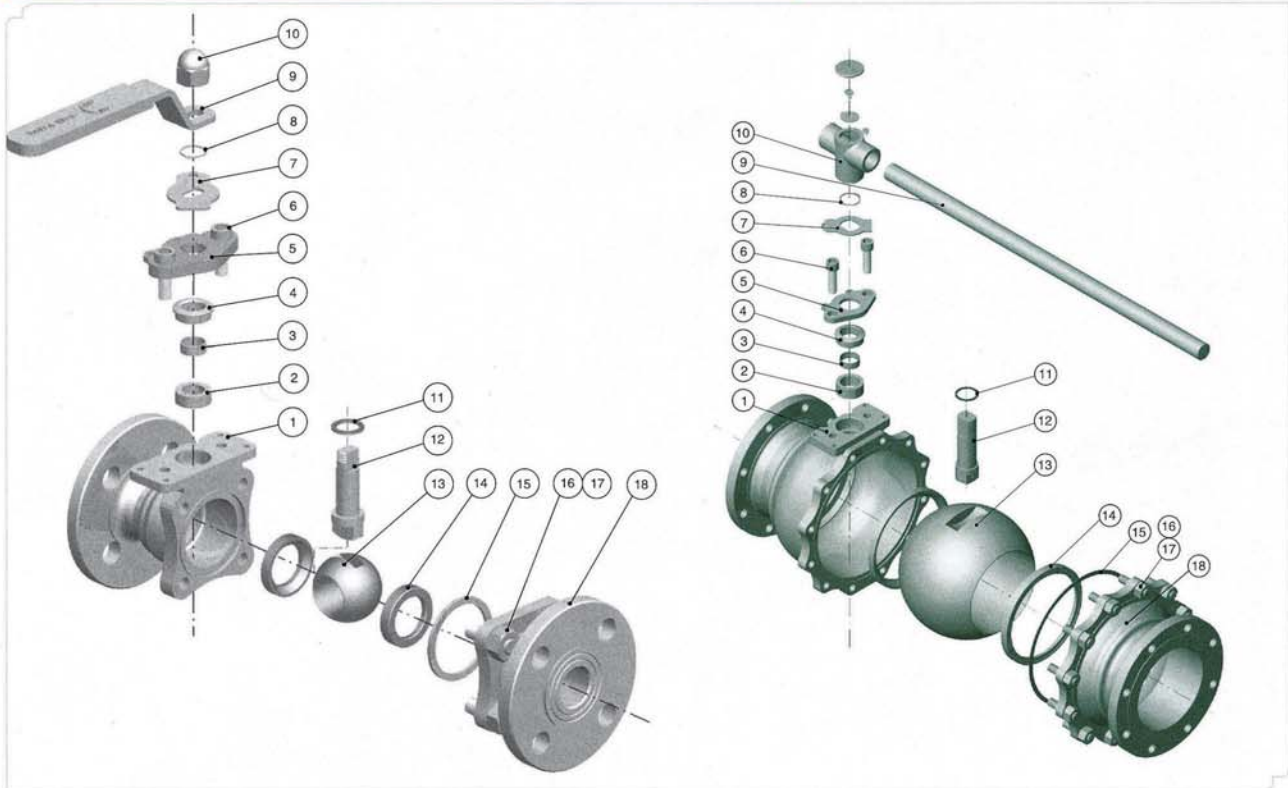

Parts and material list

Parts No.	Parts name	Materials				
		WCB/13Cr	WCB/304	WCB/316	CF8	CF8M
1	Body	ASTM A216 WCB	ASTM A216 WCB	ASTM A216 WCB	ASTM A351 CF8	ASTM A351 CF8M
2	Packing	PTFE	PTFE	PTFE	PTFE	PTFE
3	Stem bearing	PTFE	PTFE	PTFE	PTFE	PTFE
4	Gland	ASTM A182 F6a	ASTM A182 F304	ASTM A182 F316	ASTM A182 F304	ASTM A182 F316
5	Gland flange	ASTM A216 WCB	ASTM A216 WCB	ASTM A216 WCB	ASTM A351 CF8	ASTM A351 CF8M
6	Gland bolt	ASTM A193 B7	ASTM A193 B7	ASTM A193 B7	ASTM A193 B8	ASTM A193 B8M
7	Stop collar	Carbon steel	Carbon steel	Carbon steel	Stainless steel	Stainless steel
8	Circlip	Carbon steel	Carbon steel	Carbon steel	Stainless steel	Stainless steel
9	Lever	Carbon steel	Carbon steel	Carbon steel	Carbon steel	Carbon steel
10	Nut or wrench head	Carbon steel	Carbon steel	Carbon steel	Carbon steel	Carbon steel
11	Thrust washer	PTFE	PTFE	PTFE	PTFE	PTFE
12	Stem	ASTM A182 F6a	ASTM A182 F304	ASTM A182 F316	ASTM A182 F304	ASTM A182 F316
13	Ball	ASTM A182 F6a	ASTM A182 F304	ASTM A182 F316	ASTM A182 F304	ASTM A182 F316
14	Seat	Reinforced PTFE	Reinforced PTFE	Reinforced PTFE	Reinforced PTFE	Reinforced PTFE
15	Gasket	PTFE	PTFE	PTFE	PTFE	PTFE
16	Body nut	ASTM A194 2H	ASTM A194 2H	ASTM A194 2H	ASTM A194 8	ASTM A194 8M
17	Body bolting	ASTM A193 B7	ASTM A193 B7	ASTM A193 B7	ASTM A193 B8	ASTM A193 B8M
18	Closure	ASTM A216 WCB	ASTM A216 WCB	ASTM A216 WCB	ASTM A351 CF8	ASTM A351 CF8M

Note: The chart above only lists out some common composition of steel ball valve parts. We may provide other different parts material composition according to the customer's request or the actual valve working condition.

Floating ball valve

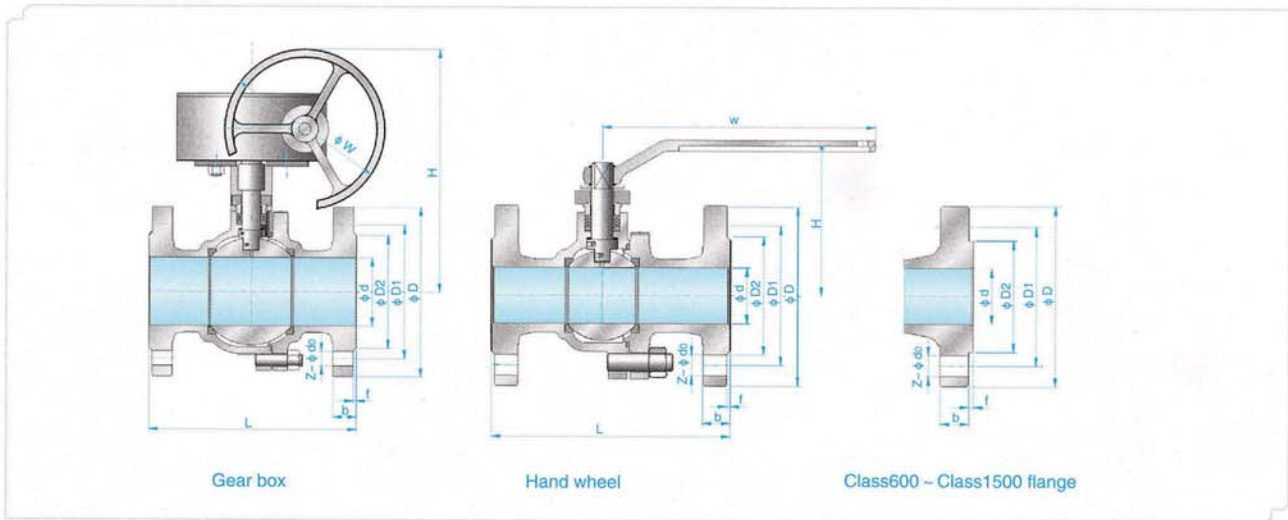

Pressure stage	Size		Dimensions (mm)								Weight (kg)	
	DN	NPS	L		d	W		H		Hand wheel	Gear box	
			RF	RTJ		Hand wheel	Gear box	Hand wheel	Gear box			
Class150 PN20	15	1/2	108	119	14	140	-	85	-	3	-	
	20	3/4	117	130	19	140	-	90	-	4	-	
	25	1	127	140	25	150	-	99	-	5	-	
	32	1 1/4	140	153	32	180	-	105	-	7	-	
	40	1 1/2	165	178	38	200	-	126	-	8	-	
	50	2	178	191	51	250	-	140	-	12	-	
	65	2 1/2	190	203	64	300	-	165	-	18	-	
	80	3	203	216	76	350	-	178	-	24	-	
	100	4	229	242	102	500	305	230	380	38	53	
	125	5	356	369	127	800	305	280	405	60	79	
	150	6	394	407	152	800	305	310	460	82	102	
200	8	457	470	203	1000	305	350	550	145	185		
250	10	533	546	254	-	400	-	706	-	280		
Class300 PN50	15	1/2	140	151	14	140	140	85	85	3	-	
	20	3/4	152	165	19	140	140	90	90	5	-	
	25	1	165	178	25	150	150	99	99	6	-	
	32	1 1/4	178	191	32	180	180	105	105	8	-	
	40	1 1/2	190	203	38	200	200	126	126	11	-	
	50	2	216	232	51	250	250	142	142	16	-	
	65	2 1/2	241	257	64	300	300	165	165	24	-	
	80	3	283	299	76	350	350	178	178	34	52	
	100	4	305	321	102	500	500	230	230	56	76	
	125	5	381	397	127	800	800	280	280	86	124	
150	6	403	419	152	800	800	310	310	125	163		
200	8	502	518	203	1000	1000	350	350	222	267		
Class600 PN110	15	1/2	165	164	14	140	-	79	-	5	-	
	20	3/4	190	190	19	140	-	83	-	7	-	
	25	1	216	216	25	200	-	114	-	9	-	
	32	1 1/4	229	229	32	200	-	120	-	13	-	
	40	1 1/2	241	241	38	250	-	125	-	17	-	
	50	2	292	295	51	300	-	156	-	25	-	
	65	2 1/2	330	333	64	350	-	172	-	42	-	
	80	3	356	359	76	500	305	220	370	56	76	
100	4	432	435	102	650	305	250	400	85	123		
Class900 PN150	15	1/2	15	216	14	150	-	98	-	9	-	
	20	3/4	20	229	20	150	-	105	-	13	-	
	25	1	25	254	25	200	-	110	-	16	-	
	32	1 1/4	32	279	32	250	-	120	-	24	-	
	40	1 1/2	40	305	38	250	-	125	-	31	-	
50	2	50	371	50	350	-	160	-	45	-		
Class1500 PN260	15	1/2	216	216	14	182	-	98	-	10	-	
	20	3/4	229	229	20	200	-	105	-	14	-	
	25	1	254	254	25	250	-	110	-	17	-	
	32	1 1/4	279	279	32	300	-	120	-	25	-	
	40	1 1/2	305	305	38	350	-	130	-	33	-	
50	2	368	371	50	500	-	160	-	48	-		



Floating ball valve

Nominal pressure	DN	15	20	25	32	40	50	65	80	100	125	150	200	250	
PN16	L	130	140	150	165	180	200	220	250	280	320	360	400	-	
	W	Hand wheel	140	140	150	180	200	250	300	350	500	800	800	1000	-
		Gear box	-	-	-	-	-	-	-	-	305	305	305	305	-
	H	Hand wheel	85	90	99	105	126	140	165	178	230	280	310	350	-
		Gear box	-	-	-	-	-	-	-	-	380	405	460	550	-
	Weight (kg)	Hand wheel	3	4	5	7	8	12	17	23	35	52	76	134	-
Gear box		-	-	-	-	-	-	-	-	53	79	102	185	-	
PN25	L	130	140	150	165	180	200	220	250	320	400	400	550	-	
	W	Hand wheel	140	140	150	180	200	250	300	350	500	800	800	1000	-
		Gear box	-	-	-	-	-	-	-	-	305	305	305	305	-
	H	Hand wheel	85	90	99	105	126	140	165	178	230	280	310	350	-
		Gear box	-	-	-	-	-	-	-	-	380	405	460	550	-
	Weight (kg)	Hand wheel	3	4	5	7	9	12	19	23	45	67	95	170	-
Gear box		-	-	-	-	-	-	-	-	53	79	102	185	-	
PN40	L	130	140	150	180	200	220	250	280	320	400	400	550	-	
	W	Hand wheel	140	140	150	180	200	250	300	350	500	800	800	1000	-
		Gear box	-	-	-	-	-	-	-	-	305	305	305	305	400
	H	Hand wheel	85	90	99	105	126	142	165	178	230	280	310	350	-
		Gear box	-	-	-	-	-	-	-	-	330	380	420	480	560
	Weight (kg)	Hand wheel	3	4	5	8	11	15	20	29	48	68	98	178	-
Gear box		-	-	-	-	-	-	-	-	47	68	88	136	223	
PN63	L	140	152	165	178	190	216	241	283	305	-	-	-	-	
	W	Hand wheel	140	140	200	200	250	300	350	500	650	-	-	-	-
		Gear box	-	-	-	-	-	-	-	305	305	-	-	-	-
	H	Hand wheel	79	83	114	120	125	156	172	220	250	-	-	-	-
		Gear box	-	-	-	-	-	-	-	390	440	-	-	-	-
	Weight (kg)	Hand wheel	5	7	9	13	17	25	42	56	85	-	-	-	-
Gear box		-	-	-	-	-	-	-	76	123	-	-	-	-	
PN100	L	165	190	216	229	241	292	330	356	432	-	-	-	-	
	W	Hand wheel	140	140	200	200	250	300	350	500	650	-	-	-	-
		Gear box	-	-	-	-	-	-	-	305	305	-	-	-	-
	H	Hand wheel	79	83	114	120	125	156	172	220	250	-	-	-	-
		Gear box	-	-	-	-	-	-	-	390	440	-	-	-	-
	Weight (kg)	Hand wheel	5	7	9	13	17	25	42	56	85	-	-	-	-
Gear box		-	-	-	-	-	-	-	76	123	-	-	-	-	
JIS 10K	L	108	117	127	140	165	178	190	203	229	356	394	457	533	
	W	Hand wheel	140	140	150	180	200	250	300	350	500	800	800	1000	-
		Gear box	-	-	-	-	-	-	-	-	305	305	305	305	400
	H	Hand wheel	85	90	99	105	126	140	165	178	230	280	310	350	-
		Gear box	-	-	-	-	-	-	-	-	380	405	460	550	706
	Weight (kg)	Hand wheel	3	4	5	7	8	12	18	24	38	60	82	145	-
Gear box		-	-	-	-	-	-	-	-	53	79	102	185	280	
JIS 20K	L	140	152	165	178	190	216	241	283	305	381	403	502	-	
	W	Hand wheel	140	140	150	180	200	250	300	350	500	800	800	1000	-
		Gear box	-	-	-	-	-	-	-	-	305	305	305	400	-
	H	Hand wheel	85	90	99	105	126	142	165	178	230	280	310	350	-
		Gear box	-	-	-	-	-	-	-	-	330	380	420	480	560
	Weight (kg)	Hand wheel	3	5	6	8	11	15	23	33	53	82	120	212	-
Gear box		-	-	-	-	-	-	-	-	52	76	124	163	267	

Floating ball valve

Forged steel ball valve

The floating ball valve manufactured by Hawks company is generally employing casted steel valve body, however, as required by customers, forged steel valve body is also available, of which the main sizes such as flange connections and face to face dimensions are the same as that of the cast steel ball valve.

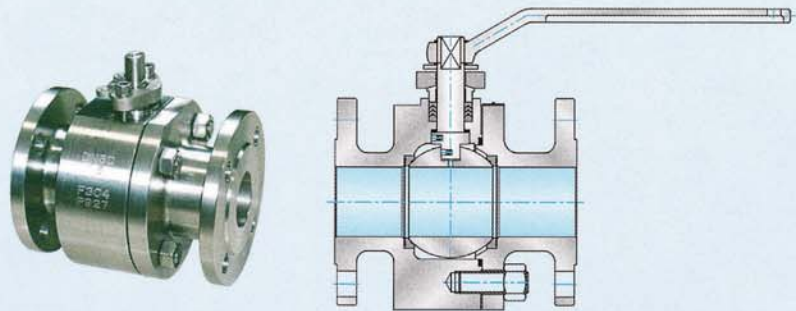

Ball valve with reduced bore

In addition to the full bore floating ball valve, Hawks is also manufacturing the floating ball valve with reduced bore to satisfy different requirement of customers, which can not only lower the cost and the pricing, but also meet customers' special requirement.

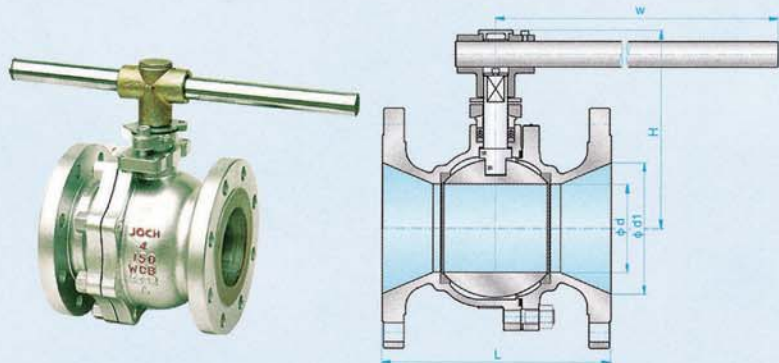

Size		Class150、PN20						Class300、PN50						Class600、PN110					
NPS	DN	L		d	d1	H	W	L		d	d1	H	W	L	d	d1	H	W	
		Long	Short					Long	Short										
1/2	15	108	108	10	14	80	140	140	140	10	14	80	140	165	10	14	75	140	
3/4	20	117	117	14	19	85	140	152	152	14	19	85	140	190	14	19	79	140	
1	25	127	127	20	25	90	140	165	165	20	25	90	140	216	20	25	83	140	
1 1/4	32	140	140	25	32	99	150	178	178	25	32	99	150	229	25	32	114	150	
1 1/2	40	165	165	32	38	105	180	190	190	32	38	105	180	241	32	38	120	200	
2	50	178	178	38	51	126	200	216	216	38	51	126	200	292	38	51	125	250	
2 1/2	65	190	190	51	64	140	250	241	241	51	64	140	250	330	51	64	156	300	
3	80	203	203	64	76	165	300	283	283	64	76	165	300	356	64	76	172	350	
4	100	229	229	76	102	178	350	305	305	76	102	178	350	432	76	102	220	500	
5	125	356	356	102	127	230	500	381	381	102	127	230	500	508	102	127	250	650	
6	150	394	267	127	152	280	800	403	403	127	152	280	800	-	-	-	-	-	
8	200	457	292	152	203	310	800	502	419	152	203	310	800	-	-	-	-	-	
10	250	533	330	203	254	350	1000	568	457	203	254	350	1000	-	-	-	-	-	

Note: 1. Sizes of flange connection of the ball valve with reduced bore are the same as that of full bore ball valves.

2. There are two series of face to face dimensions, i.e., the long series and the short series, for some of ball valves with reduced bore.

ENGINEERING DATA

CONFORMANCE STANDARDS

HAWKS VALVES CONFORM TO THE FOLLOWING STANDARDS AS APPLICABLE TO CUSTOMER REQUIREMENTS.

API Spec 6D Latest Edition API Standard 598 Latest Edition API Standard 600 Latest Edition API Standard 603 Latest Edition API Standard 605 Latest Edition	: API Specification for Pipeline Valves : Valve Inspection and Test : Steel Gate Valves, Flanged and Butt-welding Ends : Class 150, Cast Corrosion-Resistant Flanged-End Gate Valves : Large-Diameter Carbon Steel Flanges
ANSI B16.5 Latest Edition ANSI B16.10 Latest Edition ANSI B16.25 Latest Edition ANSI B16.34 Latest Edition MSS Standard Practice SP-6 Latest Edition MSS Standard Practice SP-25 Latest Edition MSS Standard Practice SP-44 Latest Edition MSS Standard Practice SP-45 Latest Edition	: Steel Pipe Flanges and Flanged Fittings : Face-to-Face and End-to-End Dimensions of Ferrous Valves : Butt-welding Ends : Valves-Flanged, Threaded, And Welding End : Standard Finishes for Contact Faces of Pipe Flanges and Connecting-End Flanges of Valves and Fittings : Standard Marking System for Valves, Fittings, Flanges and Unions : Steel Pipe Line Flanges : By-Pass and Drain Connection Standard
BS 1414 Latest Edition BS 1868 Latest Edition BS 1873 Latest Edition BS 5352 Latest Edition BS 6364 Latest Edition	: Steel wedge gate valves(flange and butt-welding ends) : Steel check valves(flange and butt-welding ends) : Steel globe and globe stop and check valves(flange and butt-welding ends) : Steel wedge gate, globe and check valves(50mm & smaller) : Valve for cryogenic service
JIS B2003 Latest Edition JIS B2201 Latest Edition JIS B2203 Latest Edition JIS B2210 Latest Edition JIS B2071 Latest Edition JIS B2073 Latest Edition JIS B2074 Latest Edition JIS B2081 Latest Edition JIS B2083 Latest Edition JIS B2084 Latest Edition JPI 7S-15 Latest Edition JPI 7S-23 Latest Edition JPI 7S-24 Latest Edition JPI 7S-39 Latest Edition JPI 7S-46 Latest Edition JPI 7S-47 Latest Edition	: General Rules for Inspection of Valves : Pressure Ratings for Ferrous Material Pipe Flanges : Tolerances for Pipe Flanges : Basic Dimensions of Ferrous Material Pipe Flanges : 10kgf/cm ² Cast Steel Flanged Globe Valves : 10kgf/cm ² Cast Steel Flanged Gate Valves(Outside Screw Type) : 10kgf/cm ² Cast Steel Flanged Swing Check Valves : 20kgf/cm ² Cast Steel Flanged Globe Valves : 20kgf/cm ² Cast Steel Flanged Gate Valves(Outside Screw Type) : 20kgf/cm ² Cast Steel Flanged Swing Check Valves : Steel Pipe Flanges for The Petroleum Industry : Ring Joint Gaskets and Grooves for Petroleum Industry : Standard Marking System for valves : Valve Inspection and Test : Cast Steel Flanged Valves for the Petroleum Industry(Class 150,300) : Cast Steel Valves for the Petroleum Industry, Flanged or Butt-welding Ends (Class600 to 2500)
API ANSI ASTM ASME ASS BS JIS JPI NACE AWS	: American Petroleum Institute : American National Standards Institute : American Society for Testing and Materials : American Society of Mechanical Engineers : Manufacturers Standardization society of the Valve and Fitting Industry : British Standards Institution : Japanese Industrial Standards : Japan Petroleum Institute : National Association of corrosion Engineers : American welding Society

ENGINEERING DATA

VALVE WALL THICKNESS

(API 603 ANSI B16.34)

• LIGHT WALL

NOMINAL SIZE		RATINGS											
		150#		300#		600#		900#		1500#		2500#	
		INCH	MM	INCH	MM	INCH	MM	INCH	MM	INCH	MM	INCH	MM
½	15	0.11	3.0	0.12	3.1	0.13	3.4	0.16	4.1	0.19	4.8	0.25	6.3
¾	20	0.12	3.1	0.15	3.8	0.16	4.1	0.18	4.6	0.23	5.8	0.29	7.4
1	25	0.16	4.1	0.19	4.8	0.19	4.8	0.22	5.6	0.26	6.6	0.35	8.9
1¼	32	0.19	4.8	0.19	4.8	0.19	4.8	0.25	6.4	0.31	7.8	0.44	11.2
1½	40	0.19	4.8	0.19	4.8	0.22	5.6	0.28	7.1	0.38	9.6	0.50	12.7
2	50	0.22	5.6	0.25	6.4	0.25	6.4	0.31	7.9	0.44	11.2	0.62	15.8
2½	65	0.22	5.6	0.25	6.4	0.28	7.1	0.34	8.6	0.50	12.7	0.75	19.0
3	80	0.22	5.6	0.28	7.1	0.31	7.9	0.41	10.4	0.62	15.7	0.88	22.4
4	100	0.25	6.4	0.31	7.8	0.38	9.6	0.50	12.7	0.75	19.0	1.09	27.7
5	125	0.28	7.1	0.38	9.6	0.44	11.2	0.59	15.0	0.91	23.1	1.34	34.0
6	150	0.28	7.1	0.38	9.6	0.50	12.7	0.72	18.3	1.09	27.7	1.59	40.4
8	200	0.31	8.1	0.44	11.2	0.62	15.8	0.88	22.4	1.41	35.8	2.06	52.3
10	250	0.34	8.6	0.50	12.7	0.75	19.0	1.06	26.9	1.72	43.7	2.59	65.8
12	300	0.38	9.6	0.56	14.2	0.91	23.1	1.25	31.8	2.00	50.8	3.03	77.0
14	350	0.41	10.4	0.62	15.8	0.97	24.6	1.38	35.0	2.19	55.6	3.34	84.8
16	400	0.44	11.2	0.69	17.5	1.09	27.7	1.56	39.6	2.50	63.5	3.81	96.8
18	450	0.47	11.9	0.75	19.0	1.22	31.0	1.75	44.4	2.81	71.4	4.27	108.5
20	500	0.50	12.7	0.81	20.6	1.34	34.0	1.91	48.5	3.12	79.2	4.69	119.1
24	600	0.57	14.5	0.94	23.9	1.59	40.4	2.28	57.9	3.72	94.5	5.72	145.3

(API 600)

• HEAVY WALL

NOMINAL SIZE		RATINGS											
		150#		300#		600#		900#		1500#		2500#	
		INCH	MM	INCH	MM	INCH	MM	INCH	MM	INCH	MM	INCH	MM
½	15	-	-	-	-	-	-	-	-	-	-	-	-
¾	20	-	-	-	-	-	-	-	-	-	-	-	-
1	25	0.25	6.4	0.25	6.4	0.31	7.9	0.50	12.7	0.50	12.7	0.59	15.0
1¼	32	0.25	6.4	0.25	6.4	0.34	8.6	0.56	14.2	0.56	14.2	0.69	17.5
1½	40	0.25	6.4	0.31	7.9	0.37	9.4	0.59	15.0	0.59	15.0	0.75	19.1
2	50	0.34	8.6	0.38	9.7	0.44	11.2	0.75	19.1	0.75	19.1	0.88	22.4
2½	65	0.38	9.7	0.44	11.2	0.47	11.9	0.88	22.4	0.88	22.4	1.00	25.4
3	80	0.41	10.4	0.47	11.9	0.50	12.7	0.75	19.1	0.94	23.9	1.19	30.2
4	100	0.44	11.2	0.50	12.7	0.63	16.0	0.84	21.3	1.13	28.7	1.41	35.8
5	125	-	-	-	-	-	-	-	-	-	-	-	-
6	150	0.47	11.9	0.63	16.0	0.75	19.1	1.03	26.2	1.50	38.1	1.91	48.5
8	200	0.50	12.7	0.69	17.5	1.00	25.4	1.25	31.8	1.88	47.8	2.44	62.0
10	250	0.56	14.2	0.75	19.1	1.13	28.7	1.44	36.6	2.25	57.2	2.66	67.6
12	300	0.63	16.0	0.81	20.6	1.25	31.8	1.66	42.2	2.63	66.8	3.41	86.6
14	350	0.66	16.8	0.88	22.4	1.38	35.1	1.81	46.0	2.75	69.9	-	-
16	400	0.69	17.5	0.94	23.9	1.50	38.1	2.06	52.3	3.13	79.5	-	-
18	450	0.72	18.3	1.00	25.4	1.63	41.4	2.25	57.2	3.50	88.9	-	-
20	500	0.75	19.1	1.06	26.9	1.75	44.5	2.50	63.5	3.88	98.6	-	-
24	600	0.81	20.6	1.19	30.2	2.00	50.8	2.88	73.2	4.50	114.3	-	-

ENGINEERING DATA

Auxiliary Connection to ANSI B16.34

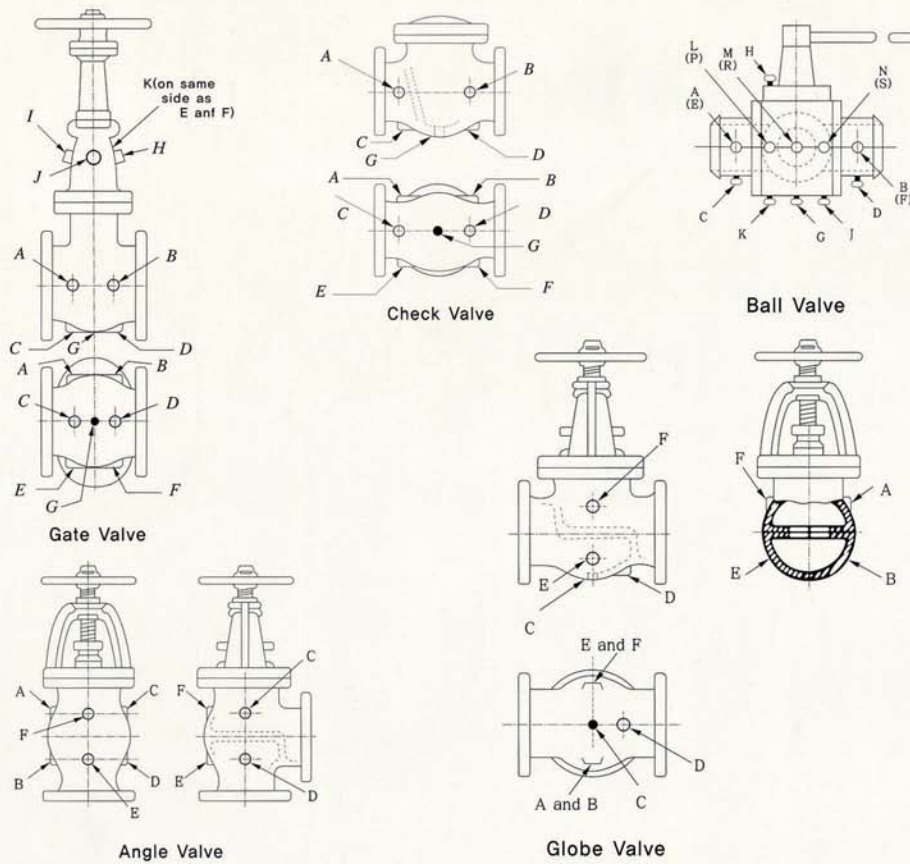

GENERAL NOTE
The above sketches represent valves with symmetrical shapes. Sketches are illustrative only and do not imply design.

METHOD OF DESIGNATING LOCATION OF AUXILIARY CONNECTIONS WHEN SPECIFIED

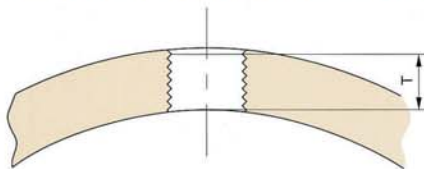

Conn Size NPS	3/8	1/2	3/4	1	1 1/4	1 1/2	2
Length of Thread, T, [Note(1)]							
in	0.41	0.53	0.55	0.68	0.71	0.72	0.76
mm	11	14	14	18	18	19	20

NOTE :
(1) In no case shall the effective length, T, be less than shown in table above. These lengths are equal to the effective thread lengths of American National External Pipe Threads (ANSI B1.1).

THREAD LENGTH FOR AUXILIARY CONNECTIONS

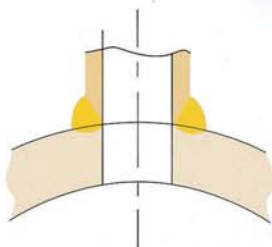

BUTTWELDING FOR AUXILIARY CONNECTIONS

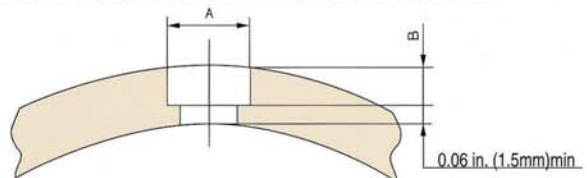

Conn. Size, NPS	3/8	1/2	3/4	1	1 1/4	1 1/2	2
Min. Dia of Socket, A							
in	0.690	0.855	1.065	1.330	1.675	1.915	2.406
mm	17.5	22	27	34	43	49	61
Min. Dia of Socket, B							
in	0.19	0.19	0.25	0.25	0.25	0.25	0.31
mm	5	5	6.5	6.5	6.5	6.5	8

SOCKET WELDING FOR AUXILIARY CONNECTIONS

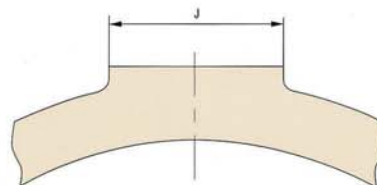

Conn Size NPS	3/8	1/2	3/4	1	1 1/4	1 1/2	2
Length of Thread, T, [Note(1)]							
in	0.41	0.53	0.55	0.68	0.71	0.72	0.76
mm	11	14	14	18	18	19	20

BOSSES FOR AUXILIARY CONNECTIONS

ENGINEERING DATA

JIS-ASTM Material Comparison List

UNS DESIGNATION	GRADE	BAR		CASTING		FORGING	
		JIS	ASTM	JIS	ASTM	JIS	ASTM
		G 4303	A276	G 5121	A 351	G 3214	A 182
AUSTENITIC STEELS							
S20910	22Cr-12Ni5Mn-2Mo-Cb-V-N-0.04C		XM-19		CG6MMN		F XM-19
S21800	17Cr-8.5Mo-8Mn-4Si-N-0.08C		—		CF102MnN		
S21904	20Cr-6.5Ni-9Mn-N-0.08C		XM-11				F XM-11
S24000	18Cr-3Ni-13Mn-N-0.06C		XM-29				
S24100	18Cr-1.5Ni-13Mn-N-0.1C		XM-28				
JIS	17Cr-7Ni-0.1C		SUS 301				
S30200	18Cr-8Ni-0.1C	SUS 302	302	SCS 12	(A743 CF-20)		(A473 302)
JIS	18Cr-8Ni-0.06C	SUS 304		SCS 13		SUS F 304	
S30400	18Cr-8Ni-0.06C	SUS 304	304	SCS 13A	CF8, 8A	SUS F 304	F304
JIS	18Cr-9Ni-Lo, C	SUS 304L		SCS 19		SUS F 304L	
S30403	18Cr-9Ni-Lo, C	SUS 304L	304L	SC519A	CF3, 3A	SUS F 304L	F304L
S30409	18Cr-8Ni-0.07C		(A479 304H)		CF10	SUS F 304H	F304H
S30430	18Cr-9Ni-3.5Cu-0.06C	SUS XM7	XM-7				
S30451	18Cr-8Ni-0.15N-0.06C	SUS 304N1	304N				F304N
S30452	18Cr-8Ni-0.25N-0.06C	SUS 304N2	XM-21				
S30453	18Cr-9Ni-0.15N-0Lo, C	SUS 304LN	304LN				F304LN
—	18Cr-13Ni-0.06C	SUS 305J1					
S30600	18Cr-15Ni-4Si-0.009C						F46
S30800	20Cr-11Ni-0.06C		308		(A743 CG12)		(A473 308)
S30815	20Cr-10Ni-1.5Si-N-Ce-0.08C		—				F45
S30880	21Cr-10Ni-2Mn-Si-0.06C		ER308				
S30900	22Cr-12Ni-0.1C		309	SCS 17	CH20		(A473 309)
S30908	22Cr-12Ni-0.06C	SUS 309S	309S		CH8		(A473 309S)
S30909	22Cr-12Ni-0.07C				CH10		(A336 F 309H)
S30940	22Cr-12Ni-Cb-0.06C		309Cb				
S31000	25Cr-20Ni-0.1C		310	SCS 18	CK20	SUS F 310	F310
S31008	25Cr-20Ni-0.06C	SUS 310S	310S				(A473 310S)
S31040	25Cr-20Ni-Cb-0.06C		310Cb				
S31254	20Cr-18Ni-6.5Mo-N-Cu-0.01C		—		CK3MCuN		F44
S31400	25Cr-20Ni-2Si-0.15C		314				(A473 314)
JIS	18Cr-12Ni-2.5Mo-0.06C	SUS 316		SCS 14		SUS F 316	
S31600	18Cr-12Ni-2.5Mo-0.06C	SUS 316	316	SCS 14A	CF8M	SUS F 316	F316
JIS	18Cr-12Ni-2.5Mo-Lo, C	SUS 316L		SCS 16		SUS F 316L	
S31603	18Cr-12Ni-2.5Mo-Lo, C	SUS 316L	316L	SCS 16A	CF3M, 3MA	SUS F 316L	F316L
S31609	18Cr-12Ni-2.5Mo-0.07C		(A479 316H)		CF10M	SUS F 316H	F316H
S31635	18Cr-12Ni-2.5Mo-Ti-0.06C		316Ti				
S31640	18Cr-13Ni-2Mo-Cb-0.06C		316Cb	SCS 22	CF10MC		
S31651	18Cr-12Ni-2.5Mo-0.15N-0.06C	SUS 316N	316N				F316N
S31653	18Cr-12Ni-2.5Mo-0.15N-Lo, C	SUS 316LN	316LN		(A743 CF-3MN)		F316LN
S31654	18Cr-12Ni-2.5Mo-0.2N-Lo, C		—		(A-743 CF-3MN)		
JIS	18Cr-12Ni-2Mo-2Cu-0.06C	SUS 316J1		BCS 15			
JIS	18Cr-12Ni-2Mo-2Cu-Lo, C	SUS 316J1L		SCS 20			
S31700	18Cr-12Ni-3.5Mo-0.06C	SUS 317	317		CG8M		F317
S31703	18Cr-12Ni-3.5Mo-Lo, C	SUS 317L					F317L
S31725	18Cr-16Ni-5Mo-Lo, C	SUS 317L	—				
S32100	18Cr-9Ni-Ti-0.06C	SUS 321	321			SUS F 321	F321
S32109	18Cr-9Ni-Ti-0.07C		(A479 321H)			SUS F 321H	F321H
S33100	8Cr-20Ni-1Si-Mn-0.15C						F10
S34700	18Cr-9Ni-Cb-0.06C	SUS 347	347	SCS 21	CF8C	SUS F 347	F347
S34709	18Cr-9Ni-Cb-0.07C		(A479 347H)			SUS F 347H	F347H
S34800	18Cr-9Ni-Cb-0.06C		318				F348
JIS	18Cr-13Ni-4Si-0.06C	SUS XM15J1					
—	20Cr-24Ni-3Mo-2Cu-3Si-0.05C				(A743 CN-7MS)		
—	20Cr-29Ni-2.5Mo-3.5Cu-0.05C			SCS 23	CN7M		
—	20Cr-33Ni-Mn-Si-Cb-0.01C				CT15C		
—	21Cr-24Ni-5Mo-Lo, C				(A743 CN-3M)		
—	25Cr-20Ni-0.3C				HK30		
—	25Cr-20Ni-0.4C				HK40		
FERRITIC-AUSTENITIC STEELS							
S31100	25Cr-6Ni-0.04C		XM-26				
S31200	25Cr-6Ni-2Mo-N-Lo, C						F50
S31803	23Cr-6Ni-3Mo-N-Lo, C		—	SCS10			F51
—	25Cr-5Ni-2Mo-3Cu-0.02C				CD4MCu		
S32900	25Cr-4.5Ni-2Mo-0.06C	SUS 329J1		SCS11			

ENGINEERING DATA

SPECIAL ALLOY STEEL

TAPE OF STEEL	GRADE	BAR		CASTING		FORGING	
		JIS	ASTM	JIS	ASTM	JIS	ASTM
Carpenter 20	Cr-Ni-Fe-Mo-Cu-Cb						
Alloy 20Cb-3	35Ni-20Cr-2.5Mo-39Fe-35Cu-Cb-0.05C		B 473 NO8020				B 462 NO8020
CN7M, SCS 23	29Ni-20Cr-2.5Mo-45Fe-35Cu-0.05C			G 5121 SCS 23	A 351 CN7N		
CN-7MS	24Ni-19Cr-2.5Mo-49Fe-2Cu-3Si-0.05C				A 743 CM-7MS		
Carpenter 20 Mod	Ni-Fe-Cr-Mo						
Alloy 20 Mod	26Ni-22Cr-5Mo-47Fe-Ti-0.03C		B 621 NO8320				B 621 NO8320
CN-3M	25Ni-21Cr-5Mo-49Fe-Lo, C				A 743 CM-3M		
Nickel	Ni						
Alloy 200	99Ni-0.1C	H 4562 NNCB	B 160 NO2200				B 160 NO2200
Alloy 201	99Ni-0.01C	H 4562 NLCB	B 160 NO2201				B 160 NO2201
CZ-100	97Ni-0.8C				A 494 CZ-100		
Duranickel 301	95Ni-4.5Al-Ti-0.2C	H 4562 NDB					
Monel	Ni-Cu						
Alloy 400	69Ni-31Cu-0.2C(Si<0.5) (S<0.024)	H4553 NCuB	B 164 NO4400				B 164 NO4400
Alloy 405	69Ni-31Cu-0.2C(Si<0.5) (S:0.025-0.06)		B 164 NO4405				B 164 NO4405
M-35-1	70Ni-30Cu-0.25C(Si<1.25)				A 494 M-351		
M-35-2	70Ni-30Cu-0.25C(Si<2.00)				A 494 M-35-2		
N-30H	67Ni-31Cu-3Si-0.2C				A 494 M-30H		
M-25S	66Ni-30Cu-4Si-0.15C				A 494 M-25S		
M-30C	66Ni-30Cu-1.5Si-2Cb-0.2C				A 494 M-30C		
Inconel	Ni-Cr-Fe(Ni-Cr-Mo-Cb)						
Alloy 600	77Ni-15Cr-8Fe-0.1C	G 4901 NCF 600	B 166 NO6600				B 564 NO6600
CY 40	77Ni-15Cr-(8Fe)-0.3C				A 494 CY-40		
Alloy 625	65Ni-22Cr-9Mo-4Cb-0.08C		B 446 NO6625				B 564 NO6625
CW-6MC	65Ni-22Cr-9Mo-4Cb-0.04C				A 494 CW-6MC		
Inconel 601	61Ni-23Cr-14Mo-1.5Al-0.08C	G 4901 NCF 601					
Inconel 690	62Ni-23Cr-9Fe-0.03C	B166 NO6690					
Inconel X-750	73Ni-16Cr-7Fe-1Cb-2.5Ti-A1-0.06C	G 4901 NCF 750	B 637 NO7750				B 637 NO7750
Inconel 751	73Ni-16Cr-7Fe-1Ni-2.5Ti-A1-0.08C	G 4901 NCF 751					
CY5SnBIM	76Ni-13Cr-3Mo-4Bi-4Sn-0.03C				A 494 CY5SnSim		
Incoloy	Ni-Fe-Cr(Ni-Fe-Cr-Mo-Cu)						
Alloy 800	33Ni-21Cr-46Fe-A1-Ti-0.08C	G 4901 NCF 800	B 408 NO8800				B 564 NO8800
Alloy 800H	33Ni-21Cr-46Fe-A1-Ti-0.075C	G 4901 NCF 800H	B 406 NO8810				B 564 NO8810
Alloy 825	42Ni-22Cr-3Mo-30Fe-2Cu-1Ti-0.03C	G 4901 NCF 825	B 425 NO8825				B 425 NO8825
Hastelloy B	Ni-Mo						
Alloy B	67Ni-28Mo-5Fe-V-0.03C		B 335 N10001				B 335 N10001
A-12MV	67Ni-28Mo-5Fe-V-0.1C				A 494 N-12MV		
Alloy B-2	72Ni-28Mo-0.01C		B 335 N10665				B 335 N10665
N-7M	68Ni-32Mo-0.05C				A 494 N-7M		
Hastelloy C	Ni-Mo-Cr						
Alloy C-276	58Ni-16Cr-16Mo-6Fe-4W-0.005C		B 574 N10276				B 335 N10276
CW-12MW	58Ni-16Cr-16Mo-6Fe-4W-V-0.01C				A 494 CW-12MW		
Alloy C-4	68Ni-16Cr-16Mo-0.008C		B 574 NO6455				B 574 NO6455
CW-2M	68Ni-16Cr-16Mo-0.01C				A 494 CW-2M		
Alloy C-22	58Ni-21Cr-14Mo-4Fe-3W-0.008C		B 574 NO6022				B 574 NO6022
CW-6M	62Ni-19Cr-19Mo-0.05C				A 494 CW-6M		
Hastelloy G	Ni-Cr-Fe-Mo-Cu						
Alloy G	46Ni-22Cr-6.5Mo-20Fe-5Mn-2Cu-0.03C		B 581 NO6007				B 581 NO6007
Alloy G-2	50Ni-25Cr-6Mo-17Fe-1Cu-1Ti-Lo, C		B 581 NO6975				B 581 NO6975
Alloy G-30	44Ni-30Cr-5Mo-15Fe-2Cu-1Cb-3W-Lo, C		B 581 NO6030				B 581 NO6030
Alloy G-3	49Ni-22Cr-7Mo-20Fe-2Cu-0.008C		B 581 NO6985				B 581 NO6985
Hastelloy N	Ni-Mo-Cr-Fe						
Alloy N	76Ni-7Cr-17Mo-0.06C		B 573 N10003				B 573 N10003
Hastelloy X	Ni-Cr-Mo-Fe						
Alloy X	48Ni-22Cr-9Mo-19Fe-1.5Co-W-0.1C		B 572 NO6002				B 572 NO6002
Js 700	Ni-Fe-Cr-9Mo-Cb						
Alloy 700	25Ni-21Cr-4.5Mo-49Fe-Cb-0.02C		B 581 NO8700				B 672 NO8700
CN-3M	25Ni-21Cr-5Mo-49Fe-Lo, C				A 743 CN-3M		
904L	Ni-Fe-Cr-Mo-Cu-Lo, C						
Alloy 904L	26Ni-21Cr-4.5Mo-47Fe-1.5Cu-0.01C		B 649 NO8904				B 649 NO8904
RA-330	Ni-Fe-Cr-Si						
Alloy 330	36Ni-19Cr-44Mo-1Si-0.06C		B 511 NO8330				B 511 NO8330
Nimonic 80A	Ni-Cr						
Nimonic 80A	76Ni-20Cr-2Ti-1.5Al-0.08C	G 4901 NCF 80A	B 637 NO7080				B 637 NO7080
IN-102	Ni-Cr-Fe-Cb-Mo-W						
IN-102	68Ni-15Cr-3Mo-7Fe-3Cb-3W-A1-TiMg-B-Z-0.06C		B 518 NO6102				
Afcorr	Ni-Cr-Mo-W						
ftcorr	55Ni-31Cr-10.5Mo-2.5W-Cb-0.1C		B 756 NO6110				B 564 NO6110
RA-333	Ni-Cr-Mo-Co-W-Fa-Si						
Alloy 333	46Ni-26Cr-3Mo-19Fe-3Co-3W-0.08C		B 719 NO6333				
AL-6X	Cr-Ni-Mo-Fe						
AL-6X	25Ni-21Cr-6.5Mo-47Fe-Lo, C		B 691 NO8366				
CN-3M	25Ni-21Cr-5Mo-49Fe-Lo, C						
AL-6XN	25Ni-21Cr-6.5Mo-47Fe-0.2N-o, C		B 691 NO8367				B 462 NO8357

ENGINEERING DATA

Chemical & Physical Properties

CASTING MATERIALS CHEMICAL PROPERTIES

	Carbon Steel	CA-15	High Temp.	High Temp.	HIGH	TEMP	304-S.S.	316-S.S.	HASTEL LOY-B	HASTEL LOY-C	304-L.S.S.	316L-S.S.	Low Temp	NICKEL	INCONEL	MONEL	A-20
ASTM Std	A-216	A-217	A-217	A-217	A-217	A-217	A-351	A-351	A-494	A-494	A-351	A-351	A-352	A-494	A-494	A-494	A-351
Grade	WCB	CA-48	WC6	WC9	C-5	C-12	CF8	CF8M	N-12M-1	CW-12M-1	CF3	CF3M	LCB	CZ-100	CY-40	M-35	CN-7M
C% MaX.	0.30	0.15	0.20	0.18	0.20	0.20	0.08	0.08	0.12	0.12	0.03	0.03	0.30	1.0	0.4	0.35	0.07
Min%	1.00 MAX.	1.00	0.05-0.08	0.40-0.70	0.40-0.70	0.35-0.65	1.50	1.50	1.00	1.0	1.50	1.50	1.00	1.5	1.5	1.5	1.5
P% MAX.	0.04	0.040	0.04	0.04	0.040	0.040	0.04	0.04	0.040	0.040	0.04	0.04	0.05	0.03	0.03	0.03	0.04
S% MAX.	0.045	0.040	0.045	0.045	0.045	0.045	0.04	0.04	0.030	0.030	0.04	0.04	0.06	0.03	0.03	0.03	0.04
Ni%	0.50	1.00	-	-	-	-	8.00	9.00	Balance	Balance	8.00-12.0	9.00-13.0	-	95.0 Min	Balance	Balance	27.5-30.5
Cr%	0.40	11.5-14.0	1.00-1.50	2.00-2.75	4.0-6.50	8.00-10.00	18.0-21.0	18.0-21.0	1.00	15.7-17.5	17.0-21.0	17.0-21.0	-	-	14-17.0	-	19.22
Mo%	0.25	-	0.45-0.65	0.90-1.20	0.45-0.65	0.90-1.20	-	2.00-3.00	26.0-30.0	16-18.0	-	2.00-3.00	-	-	-	-	2-3
Cu	0.0	-	-	-	-	-	-	-	-	0	-	-	-	1.25	-	26-33	3.4
Si	0.30	1.50	0.60	0.60	0.75	1.00	2.00	2.00	1.00	1.0	2.0	1.50	0.60	2.0	3.0	1.25	1.5
Fe	-	-	-	-	-	-	-	-4.0-6.0	4.5-6.0	-	-	-	-	3.0	11.0	3.5	-
V	-	-	-	-	-	-	-	-	0.20-0.60	0.2-0.4	-	-	-	-	-	-	-

PHYSICAL PROPERTIES

Tensile Strength	70	90-115	70	70	90-115	90-115	70	70	76	70	70	65	72	50	70	65	62
Min, Kis	485	621-493	485	485	621-793	621-793	485	185	525	485	485	450	495	345	485	450	425
Mpa																	
Yield point	30	65	40	40	60	60	28	30	40	30	30	35	40	18	28	25	25
Min, Kis	205	448	275	275	414	414	195	205	275	205	205	240	275	125	195	170	170
Mpa																	
Elongation in 2 inch (50mm) %Min	22	18	20	20	18	18	35	30	6	35	30	20	40	10.0	30.0	25.0	35.0
Reduction of Area % min	35	30	35	35	35	35	-	-	-	-	-	35	-	-	-	-	-

WROUGHT MATERIALS CHEMICAL PROPERTIES

	11-13% Cr	Ductile	Carbon Steel	B-8F	321-S.S	304L-S.S	316L-S.S	304-L-S.S	316L-S.S	Hard Facing	Bolts	Nuts
ASTM Std	A-182	A-439	ASTM	A-320	A-182	A-182	A-182	A-182	A-182	KLS	A-193	A194
Grade	F6a	D2C	A-105	B-8F	F-321	F-304	F-316	F-304L	F-316L	HF-6R	B7	2H
C% MaX.	0.15	0.29	0.22-0.35	0.15	0.08	0.08	0.08	0.035	0.035	11.05	0.38-0.48	0.40
Si% MAX.	1.00	100.3.00	0.35	1.00	1.00	1.00	1.00	1.00	1.00	1.11	0.15-0.35	-
Min% MAX.	1.00	1.80-2.40	0.60-1.05	2.00	2.00	2.00	2.00	2.00	2.00	-	0.75-1.00	-
P% MAX.	0.04	0.08	0.04	0.20	0.030	0.04	0.04	0.040	0.040	-	0.04	0.04
S% MAX.	0.03	-	0.05	0.150-0.350	0.030	0.03	0.03	0.030	0.030	-	0.04	0.05
Ni%	0.05	21.0-24.0	-	8.00-10.00	9.00-12.00	8.0-11.0	10.0-14.0	8.00-13.00	10.00-15.00	-	-	-
Cr%	11.5-14.5	0.05	-	17.00-19.00	17.00Min	18.0-20.0	16.0-18.0	18.00-20.00	16.00-18.00	28.3	0.80-1.10	-
Mo%	-	-	-	-	-	-	2.00-3.00	-	2.00-3.00	-	0.15-0.25	-
Ti%	-	-	-	-	C% x 5-0.60	-	-	-	-	-	-	-
Fi%	Bal	-	-	-	-	-	-	-	-	0.30	Bal	Bal
W%	-	-	-	-	-	-	-	-	-	4.20	-	-
Co%	-	-	-	-	-	-	-	-	-	Bal	-	-

PHYSICAL PROPERTIES

Tensile Strength	85	58	70	75	75	75	75	70	70	-	125	175
Min, Kis	586	400	483	517	517	517	517	483	483	-	862	-
Mpa												
Yield point	55	28	35	30	30	30	30	25	25	-	105	-
Min, Kis	379	193	248	207	207	207	207	172	172	-	724	-
Mpa												
Elongation in 2 inch (50mm) %Min	18	20	22	35	45	30	30	30	30	-	16	-
Reduction of Area % min	35	45	30	50	50	50	50	50	50	-	50	-

Memo