



**HAWKS**  
**PRODUCT CATALOGUE**



# API600 Cast Steel Valve Pressure Seal Valve



## API600 Cast Steel Valve

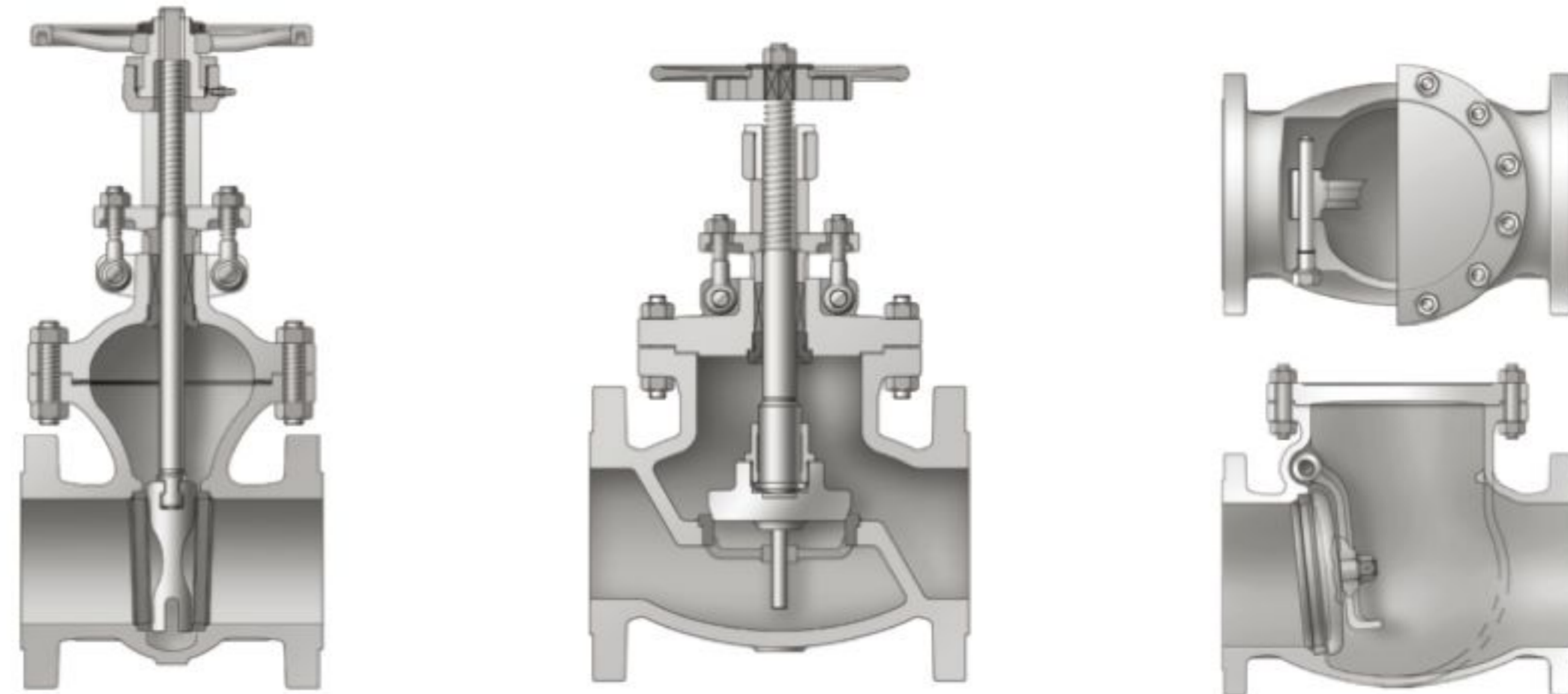

### Design Feature

- Low Emission Control(Gate Globe)
- OS&Y, Flexible Wedge(Gate)
- Plug disc(Globe)
- Optional Parabolic, Spherical or Flat Design(Globe)
- Optional Impact Hand wheel(Check)
- Optional swing or plug disc(check)
- Optional outside weight lever(Check)
- Optional stem extension (Gate & Globe)
- Optional sealing water connection(Gate & Globe)
- Optional Packing with Lantern Ring(Gate & Globe)

### Product Range

<b>Type</b>	Gate, Globe, Check
<b>Size</b>	2"~60"(DN50~DN1500)
<b>Rating</b>	150~2500LB (PN16~PN420)
<b>Body material</b>	Carbon Steel, Alloy Steel, Stainless Steel, Duplex Steel
<b>Trim</b>	Per API600
<b>End Connection</b>	RF, RTJ, BW
<b>Operation</b>	Hand wheel, Gear, Motor