

# High Performance Butterfly Valves to suit API standard 150lb/300lb Rating

## 334A

Valve nominal size

50 to 600mm

Max. working pressure MPa

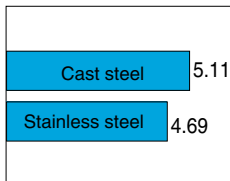

Working temperature range °C

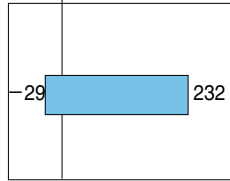

**FS** Fire safe certification to API607 4th Ed.

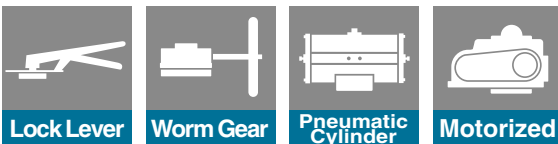
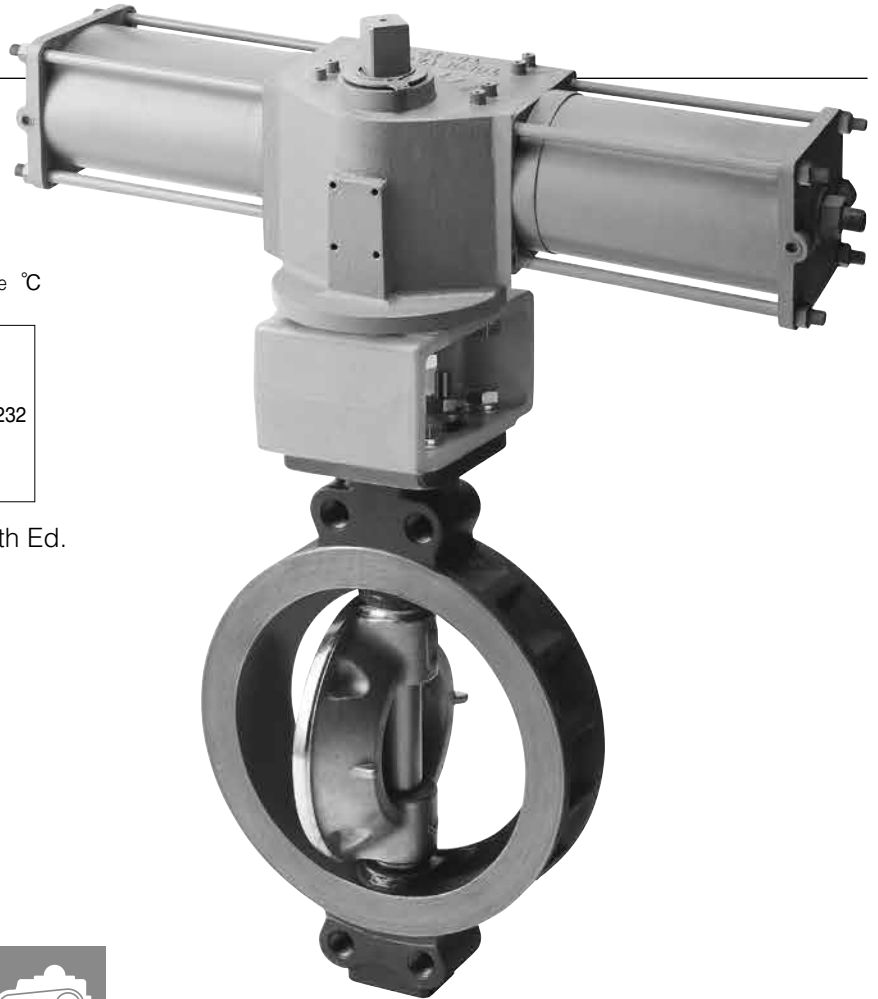

### Features and Benefits

Double Offset PTFE Seated  
High Performance Butterfly Valve to Suit API  
Standard Fire Safe Certification As Optional

#### General description

Designed to suit those severe conditions such as high temperature, high pressure or high velocity which disallow the use of soft resilient seated butterfly valves. Ideal for use including chemical processes, and applications with low pressure steam and high temperature gas. The valve is available for 150 and 300 LBS.

#### Double offset geometry

The design exhibits tight shut off, reduced torques, chemical resistance, excellent throttling capabilities, and the ability to operate with relatively high pressure drops.

Valve nominal size: 50, 80mm to 600mm  
Max. working pressure: 150Lb: 2.0MPa, 300Lb: 5.1MPa  
Working temperature range: 29 degrees C to 232 degrees C

#### Characteristics

Fire safe certification to API607 4th Ed.

50mm : API607-5th edition Fire safe  
80~600mm : API607-4th edition Fire safe ※

※ 300Lb-150mm/water body which standard is JIS16K/20K not be Applicable Fire safe. (it can not have necessary thickness.)

### RPTFE as standard

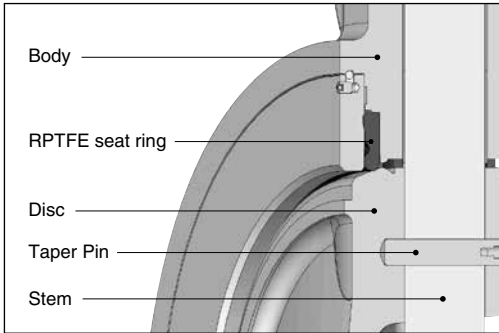

### 334A Fire Safe Seat (API607 4th Ed.)

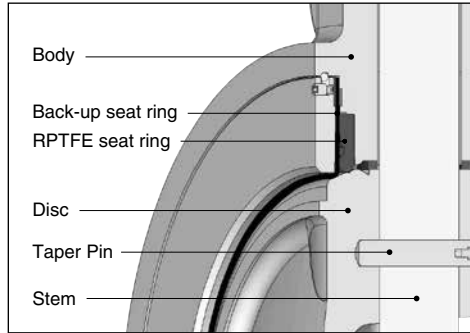

### Standard Specifications

Product characteristics		Double offset soft seated butterfly valve	
Conection		Wafer type / Lugged type	
Nominal valve size ※1		50, 80, 100, 150, 200, 250, 300, 350, 400, 450, 500, 600mm	
Applicable standards	Face-to-face dimensions	80~600mm: API609 Class150/300 Category B 50mm: API609 Category A, ISO5752 Wafer butterfly valve	
	Flange standards (Wafer)※2	150Lb: ASME/JPI Class150, JIS 10K/16K/20K, BS 4504 PN10/16, DIN PN10/16 300Lb: ASME/JPI Class300, JIS 20K/30K, BS 4504 PN25/40, DIN PN25/40	
	Actuator attachment	ISO5211/1 (other than 300Lb-600mm)	
	P-T rating	ASME B16.34 / API609	
Applicable fluid		General hydrocarbon, Chemical process, steam, gas etc.	
Max.working pressure		150Lb: 2.0MPa (Body material : Both WCB and CF8M) 300Lb: 5.1MPa (Body material : WCB), 4.96MPa (Body material : CF8M)	
Working temperature range		-29 degree C to 232 degree C	
Pressure direction		Standard pressure direction : Pressure on retainer side	
Test Pressure	Shell test	Working pressure x 1.5 times (Hydrostatic pressure)	
	Seat leakage	0.7MPa(Air pressure) Based on API598-8thEdition Option : Working pressure x 1.1 times (Hydrostatic pressure)	
Standard Materials ※3	Body	ASTM A216 WCB	ASTM A351 CF8M
	Disc	ASTM A351 CF8M with hard chrome plating	
	Shaft	SUS420J2 ※4	630SS H1150 ※4
	Seat ring	RPTFE(Carbon graphite contained)	
	Retainer	S35C ※4	316SS ※4
	Gland Packing	Graphite	
Shaft shape for actuator conection	150Lb: 50mm to 250mm : Square / 300mm to 600mm : Key 300Lb: 50mm to 150mm : Square / 200mm to 600mm : Key		
Actuator	Lock lever, Worm gear, Pneumatic cylinder, Electric motor		
Coating	Silicon resin coating (Grey N7) for 200 degrees C and lower Heat resistant silver coating for over 200 degrees C. No coating for stainless steel.		
Usable Gasket	Sheet gasket : Marketed products available Spiral wound gasket : Marketed products (with inner & outer ring) available only for ASME/JPI Class 150 and 300 For other flange standards, special gasket for TOMOE is required.		
Option	50mm : API607-5th edition Fire safe 80~600mm : API607-4th edition Fire safe ※5		

※1 Please contact us for the requirement of 125mm.

※2 Please contact us for the detail of applicable flange connection including lugged type.

※3 When materials are selected other than standard, the working pressure might be limited. Please consult with our sales for the details.

※4 In case of Body material is WCB : Shaft /SUS420J2, Retainer/S35C In case of Body materials is CF8M : Shaft/630SS+H1150, Retainer/316SS

※5 300Lb-150mm/wafer body with flange standard JIS16K/20K is not applicable to fire-safe duties.

※It is possible that seat leakage occur when fluid (e.g. powder and/or liquid) is solidified by working temperature and other cause. Consult us.  
Please note that use with vertical line such as bottom area of discharge spout of hopper, and tank.

### Model type

Type	Wafer type		Lugged type	
	150Lb	300Lb	150Lb	300Lb
Standard	324A	334A	324Q	334Q
Fire safe	344A	354A	344Q	354Q

# 334A

## 334A Expanded view of bare shaft

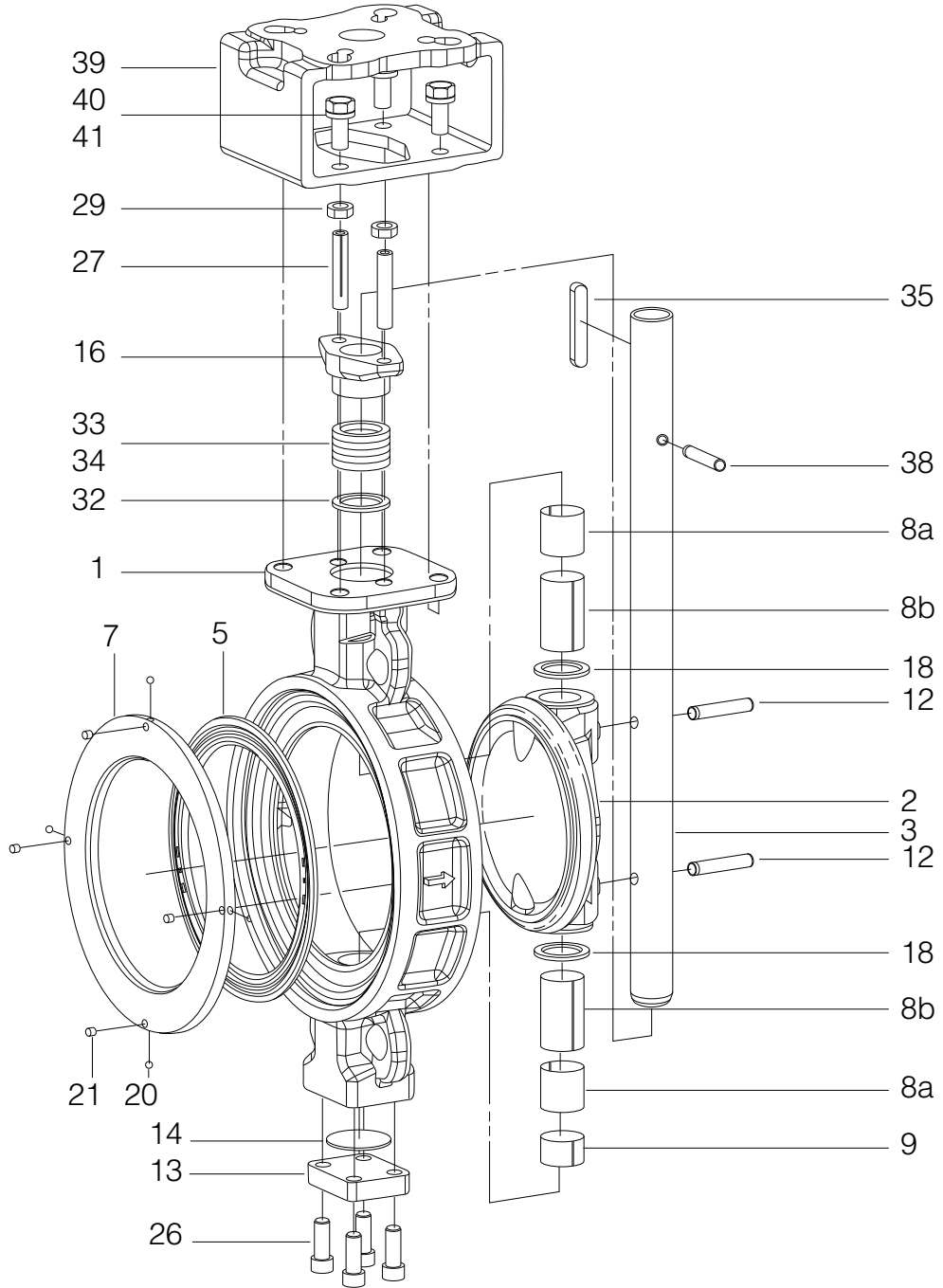

### 334A Bare shaft parts list

#### ■334A Bare shaft parts list-150Lb

No.	Description	Q'ty	Remarks
1	Body	1	
2	Disc	1	
3	Stem	1	
5	Seat ring	1	
7	Seat ring retainer	1	
8a	Bearing a	0	600mm
		1	300mm
		2	80mm to 150mm, 500mm
		3	200mm
		4	250mm, 350mm
		6	400mm, 450mm
8b	Bearing b	0	400mm, 450mm
		1	80mm, 100mm, 200mm, 250mm, 350mm
		2	150mm, 500mm
		3	300mm
		4	600mm
9	Bearing spacer	1	
12	Taper pin	2	80mm to 300mm
		3	350mm to 600mm
13	Bottom cover	1	
14	Bottom gasket	1	
16	Gland plate spigot	1	
18	Space ring	2	
20	Ball	2	80mm, 100mm
		4	150mm to 600mm
21	Set screw	2	80mm, 100mm
		4	150mm to 600mm
26	Hexagon hole bolt	4	
27	Gland bolt	2	
29	Hexagon nut	2	
32	Packing retainer	1	
33	Gland packing a	3	
34	Gland packing b	2	
35	Key	0	80mm to 150mm
		1	200mm to 600mm
38	Spring pin	1	
39	Column	1	
40	Hexagon bolt	4	
41	Spring washer	4	

#### ■334A Bare shaft parts list-300Lb

No.	Description	Q'ty	Remarks
1	Body	1	
2	Disc	1	
3	Stem	1	
5	Seat ring	1	
7	Seat ring retainer	1	
8a	Bearing a	2	
8b	Bearing b	1	80mm to 150mm
		2	200mm to 600mm
9	Bearing spacer	1	
12	Taper pin	2	80mm to 200mm
		3	250mm to 600mm
13	Bottom cover	1	
14	Bottom gasket	1	
16	Gland plate spigot	1	
18	Space ring	2	
20	Ball	2	80mm, 100mm
		4	150mm to 600mm
21	Set screw	2	80mm, 100mm
		4	150mm to 600mm
26	Hexagon hole bolt	4	
27	Gland bolt	2	
29	Hexagon nut	2	
32	Packing retainer	1	
33	Gland packing a	3	
34	Gland packing b	2	
35	Key	0	80mm to 150mm
		1	200mm to 600mm
38	Spring pin	1	
39	Column	1	
40	Hexagon bolt	4	
41	Spring washer	4	

# 334A

## 334A Actuator Selection Chart

### 334A-150Lb

Type	Model	Category	Size ( $\frac{mm}{inch}$ )												
			50	80	100	150	200	250	300	350	400	450	500	600	
			2	3	4	6	8	10	12	14	16	18	20	24	
Lock lever	1T	T10	1T-1	1T-2											
		T20													
Worm gear	2U,2K	T10	2U-1	2U-2	2U-3	2U-4	2K (SBWG-01)	2K (SBWG-02)	2K (SBWG-03)	2K (SBWG-04-1S)					
		T20													
Double-action pneumatic	7E,3A	T10	T85	T200	T380	T750	TGA-125	TGA-140	TGA-160	TGA-180					
		T20									TGA-140	TGA-160	TGA-180	TGA-200	
Single-action pneumatic	7G,7F 3U,3K	T10	T200S	T380S	T750S	TG-12S	TG-14S	TG-20S							
		T20													
Single phase motor	4I	T10	4I-0	4I-1	4I-2	4I-2.5	4I-3	4I-4							
		T20													

## 334A Pressure - Temperature

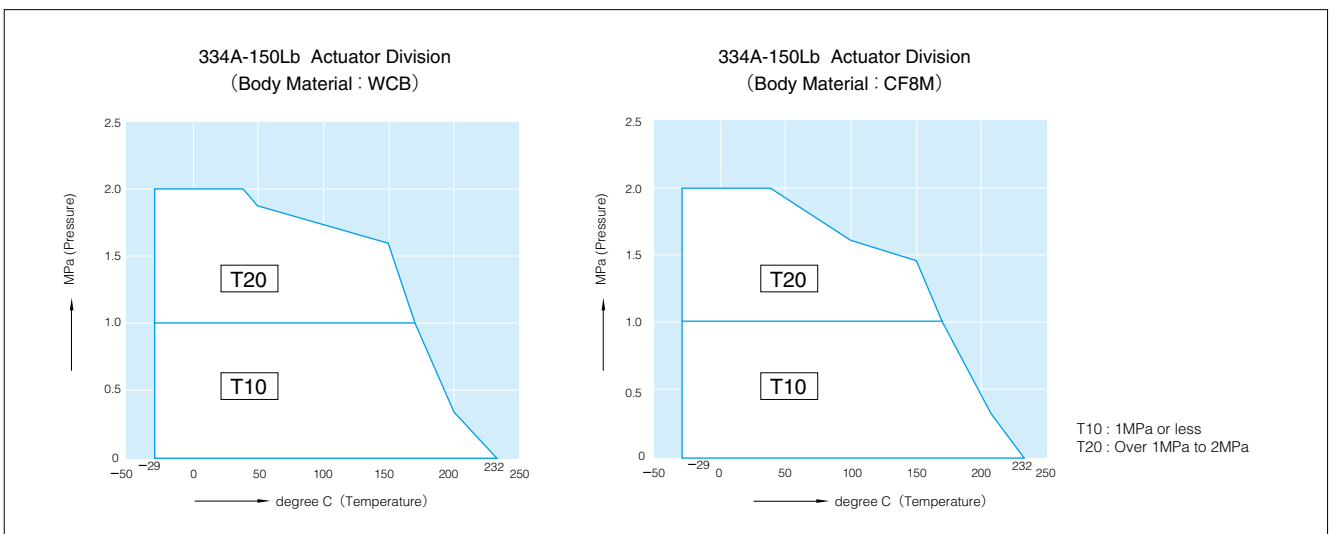

# 334A

## 334A Bare Shaft Dimension

### 150Lb

Nominal size		Dimension (mm)															Approx. Weight (kg)
mm	inch	$\phi d$	$\phi D$	L	L <sub>2</sub>	H <sub>1</sub>	H <sub>2</sub>	a <sub>1</sub>	a <sub>2</sub>	$\square S_1$	$\phi d_2$	b	t <sub>2</sub>	H <sub>4</sub>	t	Top Flange type	
50	2	60	97	43	17.5	102.5	102.5	22.5	11.5	12	14	—	—	70	8	F07, F10	5.7
80	3	86.5	128	48	20	118	127	26.5	16.5	14	18	—	—	70	8	F07, F10	8
100	4	112	158	54	22	147	149	26.5	20	16	20	—	—	70	8	F07, F10	10.7
150	6	160	216	57	23	186	190	26.5	20	18	22	—	—	98	12	F10, F12, F14	18.9
200	8	210	270	64	26.5	201	209.2	37	30	22	26	—	—	98	12	F10, F12, F14	25.6
250	10	260	324	71	29	254	253	37	34	24	30	—	—	98	12	F10, F12, F14	39
300	12	310	382	81	36	283	280.5	72	67	—	32	10	3	98	12	F10, F12, F14	49
350	14	347	415	92	37	313	301	72	67	—	37	10	3	125	16	F14, F16	73
400	16	402	473	102	40	348	350	86	81	—	42	12	3	125	16	F14, F16	101
450	18	446	534	114	46	394	383.6	86	81	—	45	14	3.5	125	16	F14, F16	145
500	20	497	586	127	55	421	409.2	86	81	—	52	16	4	125	16	F14, F16	179
600	24	600	694	154	70	481	473	116	111	—	60	18	4	150	20	Special A, Special B	304

### 150Lb 80mm to 600mm

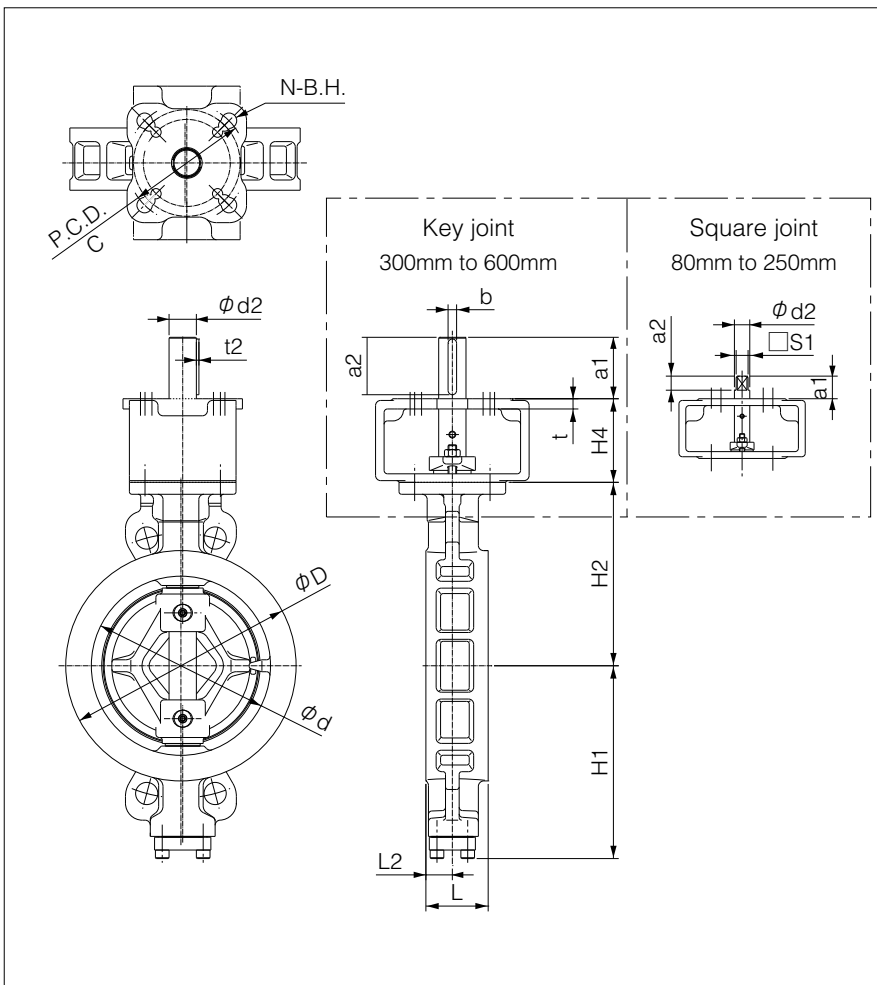

### Top Flange Type Dimension List

Flange type	P.C.D. C	N	B.H.
F07	70	4	10
F10	102	4	12
F12	125	4	14
F14	140	4	18
F16	165	4	22
F25	254	8	18
Special A	220	4	22
Special B	254	8	22

# 334A

## Worm Gear Type-150Lb 334A-2U(50 to 300mm) / 334A-2K(350 to 600mm)

### 150Lb

Nominal size		Dimension (mm)												Gear type	Approx. Weight (kg)
mm	inch	$\phi d$	$\phi D$	L	$L_2$	$H_1$	$H_2$	$H_3$	$H_4$	E	K	F	$\phi W$		
50	2	60	97	43	17.5	102.5	102.5	29.5	70	36	74	160	100	2U-1	8
80	3	86.5	128	48	20	118	127	34.5	70	44	74	173.5	160	2U-2	12.5
100	4	112	158	54	22	147	149	34.5	70	44	74	173.5	160	2U-2	15
150	6	160	216	57	23	186	190	41.5	98	67	90	198	200	2U-3	27
200	8	210	270	64	26.5	201	209.2	41.5	98	67	90	198	200	2U-3	34
250	10	260	324	71	29	254	253	48	98	87.5	90	222.5	280	2U-4	55
300	12	310	382	81	36	283	280.5	48	98	87.5	90	222.5	280	2U-4	65
350	14	347	415	92	37	313	301	52	125	75	113	252	370	SBWG-01	79
400	16	402	473	102	40	348	350	63	125	91.5	113	310	450	SBWG-02	123
450	18	446	534	114	46	394	384	63	125	113	113	343	550	SBWG-03	173
500	20	497	586	127	55	421	409	63	125	113	113	343	550	SBWG-03	207
600	24	600	694	154	70	481	473	85	150	32.7	200	422	710	SBWG-04-1S	363

### 334A-2U/2K

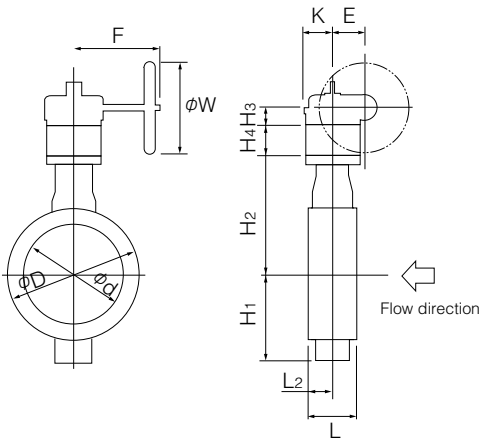

### 2U/2K Installation Direction

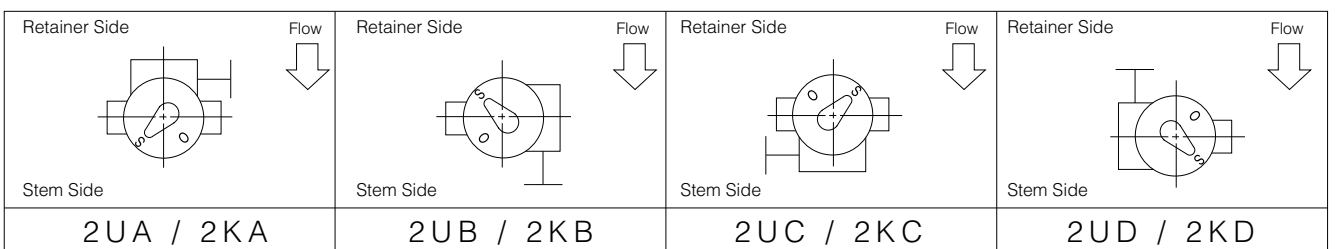

## 334A-150Lb Cv value and pressure loss coefficient

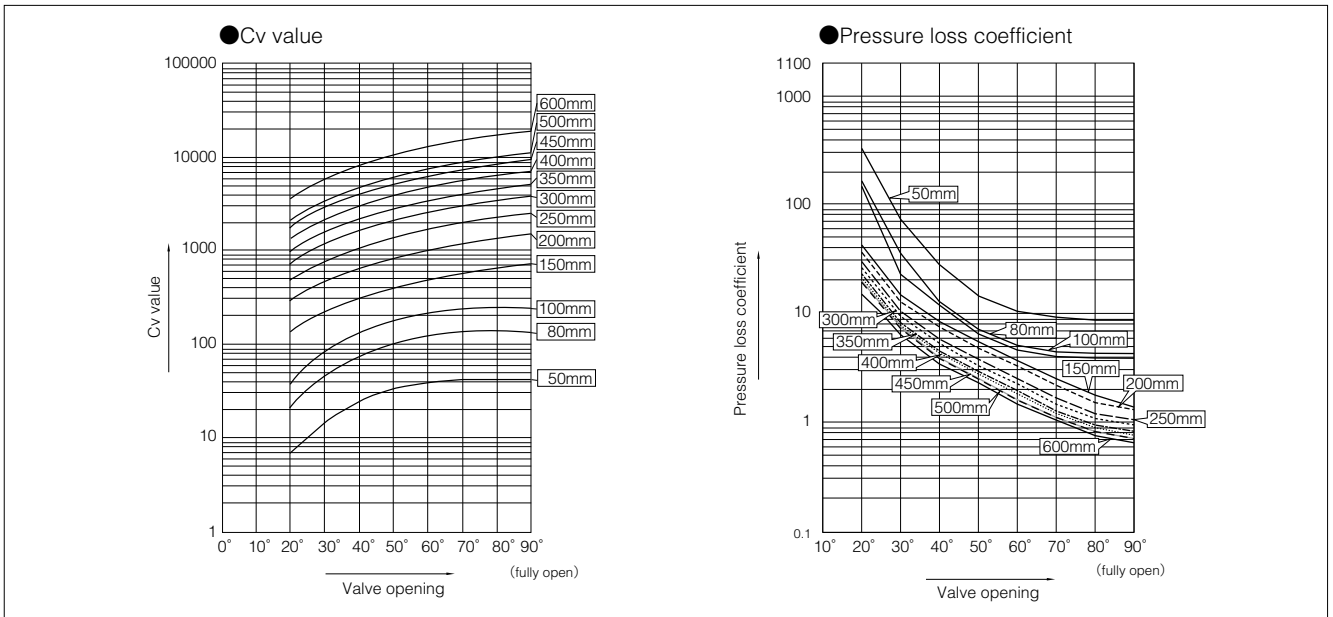

### 334A -150Lb Cv value

Nominal size		Valve opening							
mm	inch	20°	30°	40°	50°	60°	70°	80°	90°
50	2	7	15	24	33	39	42	43	43
80	3	22	47	77	104	124	134	135	136
100	4	38	83	135	184	219	236	238	240
150	6	140	231	310	385	471	573	677	729
200	8	295	488	655	814	995	1211	1430	1540
250	10	479	792	1063	1321	1615	1966	2321	2500
300	12	747	1236	1659	2061	2519	3066	3621	3900
350	14	1002	1657	2225	2765	3378	4112	4856	5230
400	16	1379	2281	3063	3806	4651	5661	6685	7200
450	18	1835	3035	4075	5064	6188	7533	8895	9580
500	20	2146	3549	4764	5920	7235	8806	10399	11200
600	24	3583	5925	7955	9885	12080	14703	17362	18700

### 334A -150Lb Pressure loss coefficient

Nominal size		Valve opening							
mm	inch	20°	30°	40°	50°	60°	70°	80°	90°
50	2	33.6	73.3	28.6	15.1	10.8	9.4	8.9	8.9
80	3	171.9	36.3	13.5	7.3	5.2	4.4	4.4	4.3
100	4	156.9	33.2	12.3	6.7	4.7	4.1	4.0	3.9
150	6	42.5	15.6	8.6	5.6	3.7	2.5	1.8	1.6
200	8	37.5	13.7	7.6	4.9	3.3	2.2	1.6	1.4
250	10	29.3	10.7	5.9	3.8	2.6	1.7	1.3	1.1
300	12	25.8	9.4	5.2	3.4	2.3	1.5	1.1	1.0
350	14	22.2	8.1	4.5	2.9	2.0	1.3	1.0	0.8
400	16	21.2	7.8	4.3	2.8	1.9	1.3	0.9	0.8
450	18	19.3	7.1	3.9	2.5	1.7	1.1	0.8	0.7
500	20	19.2	7.0	3.9	2.5	2.1	1.1	0.8	0.7
600	24	18.0	6.6	3.6	2.4	1.6	1.1	0.8	0.7



## 334A Applicable Flange Standard Table

### ■150Lb Wafer Type

Nominal size		ASME/JPI 50Lb	JIS 10K	JIS 16/20K	BS4504(DIN) PN 10	BS4504(DIN) PN 16
mm	inch					
50	2	○*1	○*1	D*2	D*2	○*1
80	3	○*1	D*2	D*2	D*2	D*2
100	4	D*2	D*2	D*2	D*2	D*2
150	6	D*2	D*2	D*2	D*2	D*2
200	8	D*2	D*2	D*2	D*2	D*2
250	10	D*2	D*2	D*2	D*2	D*2
300	12	D*2	D*2	D*2	D*2	D*2
350	14	D*2	D*2	D*2	D*2	D*2
400	16	D*2	D*2	D*2	D*2	D*2
450	18	T	T	T	T	T
500	20	T	T	T	T	T
600	24	T	T	T	T	T

\*1 : Can be used without flange drilling.

\*2 : There are 2 upper drilling holes for 50mm and 80mm to 250mm types, and a total of 4 drilling holes, 2 upper and 2 lower, for 300mm to 400mm types.

D: With flange drilling

T: With flange tapping

○: Can be used without flange drilling.

### ■150Lb Lugged Type

Nominal size		ASME/JPI 50Lb	JIS 10K	JIS 16/20K	BS4504(DIN) PN 10	BS4504(DIN) PN 16
mm	inch					
50	2	T	T	T*1	T	T
80	3	T	T*1	T*1	T*1	T*1
100	4	T*1	T*1	T*1	T*1	T*1
150	6	T	T	T*1	T	T
200	8	T	×	T*1	T	T*1
250	10	T	T	T	T	T
300	12	T	×	T*1	T	T
350	14	T	×	×	×	×
400	16	T	T	T	T	T
450	18	T	×	×	×	×
500	20	T	T	T	T	T
600	24	T	×	T*1	T	T

\*1 : Use 300Lb body. In this case, 300Lb body of 150mm or more in the nominal size must note that the face-to-face dimensions are different.

\* : Please consult with us regarding drilling holes for the lugged type.

T: With flange tapping

×: A special wooden form is required.

## 334A-300Lb/150Lb Applicable Pipe List in Case

Nominal size		JIS (STPG)			ANSI B36.1		
mm	inch	Sch#40	Sch#60	Sch#80	Sch#40	Sch#60	Sch#80
50	2	○	○	○	○	X	○
80	3	○	○	○	○		○
100	4	○	○	○	○		○
150	6	○	○	○	○		○
200	8	○	○	○	○	○	○
250	10	○	○	○	○	○	○
300	12	○	○	○	○	○	○
350	14	○	○	○	○	○	○
400	16	○	○	○	○	○	○
450	18	○	○	○	○	○	○
500	20	○	○	○	○	○	○
600	24	○	○	○	○	○	○

※ Determine the appropriateness of using other pipes according to the minimum internal pipe diameter indicated in the following table.

## 334A Minimum Internal Diameters of Piping

Nominal size		Minimum internal diameters of piping	
mm	inch	150Lb	300Lb
50	2	45	45
80	3	73	73
100	4	93	93
150	6	138	138
200	8	186	185
250	10	226	225
300	12	268	267
350	14	310	306
400	16	354	347
450	18	402	394
500	20	444	438
600	24	535	533

※ The gap between the disc edge and the pipe is smallest at the stem side flange face when all nominal sizes are fully open.

※ Because the above gap is calculated with the pipe considered as extending up to the flange end, the value will differ depending on the way the pipe and flange are welded.

## 334A Piping Gasket

- \* In case of sheet gasket ..... Any standard can be used.
- \* In case of spiral gasket
  - For API, JPI, ANSI flange ..... Any standard gaskets with inner/outer ring can be used.
  - For JIS flange ..... Use special spiral gasket shown below.

### ● 334A Special Spiral Gasket Flange Size

Nominal size		D <sub>1</sub>	D <sub>2</sub>	D <sub>3</sub>	D <sub>4</sub>								
					ASME JPI		JIS			BS4504			
mm	inch				Class 150	Class 300	10K	16/20K	30K	PN10	PN16	PN25	PN40
50	2	61	69	88	104	111	104	104	114	109	109	109	109
80	3	89	97	120	136	148	134	140	150	144	144	144	144
100	4	115	124	145	174	180	159	165	172	164	164	170	170
150	6	166	178	205	222	250	220	237	249	220	220	226	226
200	8	217	227	256	279	307	270	282	294	275	275	286	293
250	10	268	278	315	339	362	332	354	360	330	331	343	355
300	12	319	339	370	409	422	377	404	418	380	386	403	420
350	14	256	369	403	450	485	422	450	463	440	446	460	477
400	16	406	420	457	514	539	484	508	524	491	498	517	549
450	18	458	472	517	549	596	539	573	—	541	558	567	574
500	20	508	523	567	606	654	594	628	—	596	620	627	631
600	24	610	626	672	717	774	700	734	—	698	737	734	750

※ Using 334A gasket for size 300, 350mm.  
Using TOMOE 300 series for other.

Remark : In case a minute leakage of gas (less than 100PPm) becomes a problem, please inquire of our business charge.

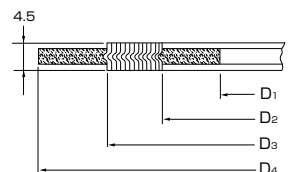

● **Commercially Available Spiral Gaskets (with inner and outer ring)**

Nominal size		ASME/JPI	JIS			BS4504
mm	inch	150/300Lb	10K	16K/20K	30K	PN10, 16, 25, 40
50	2	○	○	○	○	○
80	3	○	○	○	×	○
100	4	○	×	○	×	○
150	6	○	×	×	×	×
200	8	○	×	×	×	×
250	10	○	×	×	×	×
300	12	○	×	○	×	×
350	14	○	×	×	×	○
400	16	○	×	×	○	○
450	18	○	×	×	—	○
500	20	○	×	×	—	○
600	24	○	×	×	—	○

○: Can be use, ×: Can not be used, —: No Standard

**334A Applicable Gasket Standard Table for Piping**

Nominal size		Joint sheet and RPTFE solid gasket (t≤2mm)				*PTFE mold type gasket VALQUA or NICHIASU	
		ASME/JPI	JIS		BS4504	ASME/JPI	JIS
mm	inch	150/300Lb	10K, 16K, 20K	30K	PN10,16,25,40	150/300Lb	10K, 16K, 20K
50	2	○	○	○	○	○	○
80	3	○	○	○	○	○	○
100	4	○	○	○	○	○	○
150	6	○	○	○	○	○	○
200	8	○	○	○	○	○	○
250	10	○	○	○	○	○	○
300	12	○	○	○	○	○	○
350	14	○	○	○	○	○	○
400	16	○	○	○	○	○	○
450	18	○	○	—	○	○	○
500	20	○	○	—	○	○	○
600	24	○	○	—	○	○	○

\*All standard joint seats and PTFE cut gaskets can be used.

\*Only VALQUA flawless gaskets (Part No.: 7030/7031/7035) and NICHIAS PTFE cushion gaskets (Part No.: 9010/9011) can be used.  
(Products from other manufacturers cannot be used due to their dimensions.)

## 334A Piping Bolts and Nuts Sizes

### ■150Lb Wafer Type

Nominal size		ASME/JPI class150			JIS10K		
mm	inch	Setting Bolts	Long Bolts	No.of Nuts	Setting Bolts	Long Bolts	No.of Nuts
50	2	—	4- 5/8-11UNC×140	8	—	4-M16×135	8
80	3	—	4- 5/8-11UNC×160	8	—	8-M16×145	16
100	4	—	8- 5/8-11UNC×160	16	—	8-M16×145	16
150	6	—	8- 3/4-10UNC×175	16	—	8-M20×170	16
200	8	—	8- 3/4-10UNC×185	16	—	12-M20×180	24
250	10	—	12- 7/8-9UNC×205	24	—	12-M22×190	24
300	12	—	12- 7/8-9UNC×220	24	—	16-M22×200	32
350	14	—	12- 1-8UNC ×245	24	—	16-M22×215	32
400	16	—	16- 1-8UNC ×260	32	—	16-M24×240	32
450	18	8-1 1/8-8UN×140(24×16)	12-1 1/8-8UN ×285	32	8-M24×120(21×14)	16-M24×250	40
500	20	8-1 1-8-8UN×145(24×16)	16-1 1-8-8UN ×300	40	8-M24×120(21×14)	16-M24×260	40
600	24	8-1 1/4-8UN×150(24×16)	16-1 1/4-8UN ×345	40	8-M30×135(24×16)	20-M30×310	48

Nominal size		JIS16K			JIS20K		
mm	inch	Setting Bolts	Long Bolts	No.of Nuts	Setting Bolts	Long Bolts	No.of Nuts
50	2	—	8-M20 ×135	16	—	8-M20 ×135	16
80	3	—	8-M20 ×160	16	—	8-M20 ×160	16
100	4	—	8-M20 ×170	16	—	8-M20 ×170	16
150	6	—	12-M22 ×175	24	—	12-M22 ×190	24
200	8	—	12-M22 ×190	24	—	12-M22 ×200	24
250	10	—	12-M24 ×210	24	—	12-M24 ×220	24
300	12	—	16-M24 ×220	32	—	16-M24 ×230	32
350	14	—	16-M30(P3)×250	32	—	16-M30(P3)×260	32
400	16	—	16-M30(P3)×275	32	—	16-M30(P3)×285	32
450	18	8-M30(P3)×140(24×16)	16-M30(P3)×285	40	8-M30(P3)×150(24×16)	16-M30(P3)×300	40
500	20	8-M30(P3)×145(24×16)	16-M30(P3)×300	40	8-M30(P3)×155(24×16)	16-M30(P3)×315	40
600	24	8-M36(P3)×160(30×20)	20-M36(P3)×355	48	8-M36(P3)×170(30×20)	20-M36(P3)×365	48

Nominal size		BS4504 PN10*			BS4504 PN16*		
mm	inch	Setting Bolts	Long Bolts	No.of Nuts	Setting Bolts	Long Bolts	No.of Nuts
50	2	—	4-M16×135	8	—	4-M16×135	8
80	3	—	8-M16×145	16	—	8-M16×145	16
100	4	—	8-M16×155	16	—	8-M16×155	16
150	6	—	8-M20×170	16	—	8-M20×170	16
200	8	—	8-M20×180	16	—	12-M20×180	24
250	10	—	12-M20×190	24	—	12-M24×200	24
300	12	—	12-M20×200	24	—	12-M24×220	24
350	14	—	16-M20×210	32	—	16-M24×230	32
400	16	—	16-M24×230	32	—	16-M27×250	32
450	18	8-M24×115(21×14)	16-M24×250	40	8-M27×125(22×14)	16-M27×265	40
500	20	8-M24×115(21×14)	16-M24×260	40	8-M30×140(24×16)	16-M30×285	40
600	24	8-M27×120(22×14)	16-M27×310	40	8-M33×150(27×18)	16-M33×330	40

## 334A Piping Bolts and Nuts Sizes

### ■ 150Lb Lugged Type (All taps)

Nominal size		ASME/JPI class 150		JIS10K		JIS16K	
mm	inch	Setting Bolts	No. of Nuts	Setting Bolts	No. of Nuts	Setting Bolts	No. of Nuts
50	2	8- 5/8-11UNC× 75(13× 8)	8	8-M16×75(13× 8)	8	8-M16× 75(13× 8)	8
80	3	8- 5/8-11UNC× 85(13× 8)	8	16-M16×75(13× 8)	16	16-M20× 85(17×11)	16
100	4	16- 5/8-11UNC× 85(13× 8)	16	16-M16×75(13× 8)	16	16-M20× 90(17×11)	16
150	6	16- 3/4-10UNC× 95(17×11)	16	16-M20×90(17×11)	16	—	—
200	8	16- 3/4-10UNC×100(17×11)	16	—	—	—	—
250	10	24- 7/8- 9UNC×115(19×12)	24	24-M22×105(19×12)	24	24-M24×115(21×14)	24
300	12	24- 7/8- 9UNC×115(19×12)	24	—	—	—	—
350	14	24- 1-8UNC×125(21×14)	24	—	—	—	—
400	16	32- 1-8UNC×125(21×14)	32	32-M24×115(21×14)	32	32-M30(P3)×140(24×16)	32
450	18	32-1 1/8-8UN ×140(24×16)	32	—	—	—	—
500	20	40-1 1/8-8UN ×145(24×16)	40	40-M24×125(21×14)	40	40-M30(P3)×150(24×16)	40
600	24	40-1 1/4-8UN ×160(24×16)	40	—	—	—	—

Nominal size		JIS20K		BS4504 PN10**		BS4504 PN16**	
mm	inch	Setting Bolts	No. of Nuts	Setting Bolts	No. of Nuts	Setting Bolts	No. of Nuts
50	2	8-M16× 75(13× 8)	8	8-M16× 75(13× 8)	8	8-M16× 75(13× 8)	8
80	3	16-M20× 85(17×11)	16	16-M16× 75(17×11)	16	16-M16× 75(13× 8)	16
100	4	16-M20× 90(17×11)	16	16-M16× 75(17×11)	16	16-M16× 75(13× 8)	16
150	6	—	—	16-M20× 90(17×11)	16	16-M20× 90(17×11)	16
200	8	—	—	16-M20× 95(17×11)	16	—	—
250	10	24-M24×125(21×14)	24	24-M20×105(17×11)	24	24-M24×115(21×14)	24
300	12	—	—	24-M20×105(17×11)	24	24-M24×115(21×14)	24
350	14	—	—	—	—	—	—
400	16	32-M30(P3)×145(24×16)	32	32-M24×115(21×14)	32	32-M27×125(22×14)	32
450	18	—	—	—	—	—	—
500	20	40-M30(P3)×155(24×16)	40	40-M24×120(21×14)	40	40-M30×140(24×16)	40
600	24	—	—	40-M27×125(22×14)	40	40-M33×150(27×18)	40

Note: Bolt/Nut material: SNB7/S45C

Please use a nut with a height that is 100% of the screw diameter.

The bolt length calculation is based on use of a 4.5 mm thick spiral gasket.

The flange thickness calculation is based on the standard steel flange thickness.

\*\* Mark: The flange thickness calculation is based on the welding neck flange thickness.

Quantities shown are for one valve.

#### Examples

Setting bolts: 8 - M16 × 75 (13 × 8)

Long bolts: 4 - M16 × 145

