

FORGED STEEL VALVES

DOUGLAS CHERO SpA
dc FORGED VALVES



Ratings (ASTM A105)

2500 p.s.i. @ 850°F
6170 p.s.i. @ 100°F

Test pressure (ASTM A105)

Hydraulic: (minimum)
Body - 9275 p.s.i.
Seat - 6800 p.s.i.
Air under water:
Seat - 85 p.s.i.

Standards

Construction founded on ASME B16.34
Socket weld ASME B16.11
Threaded ASME B1.20.1
Butt weld ASME B16.25
Test API 598-ASME B16.34

Connections (xx)

SW Socket weld	BX Butt weld XXS
TH Threaded NPT	
TS Sw/NPT	
SE Sw (in)/NPT	
SU Sw (out)/NPT	
B6 Butt weld 160	

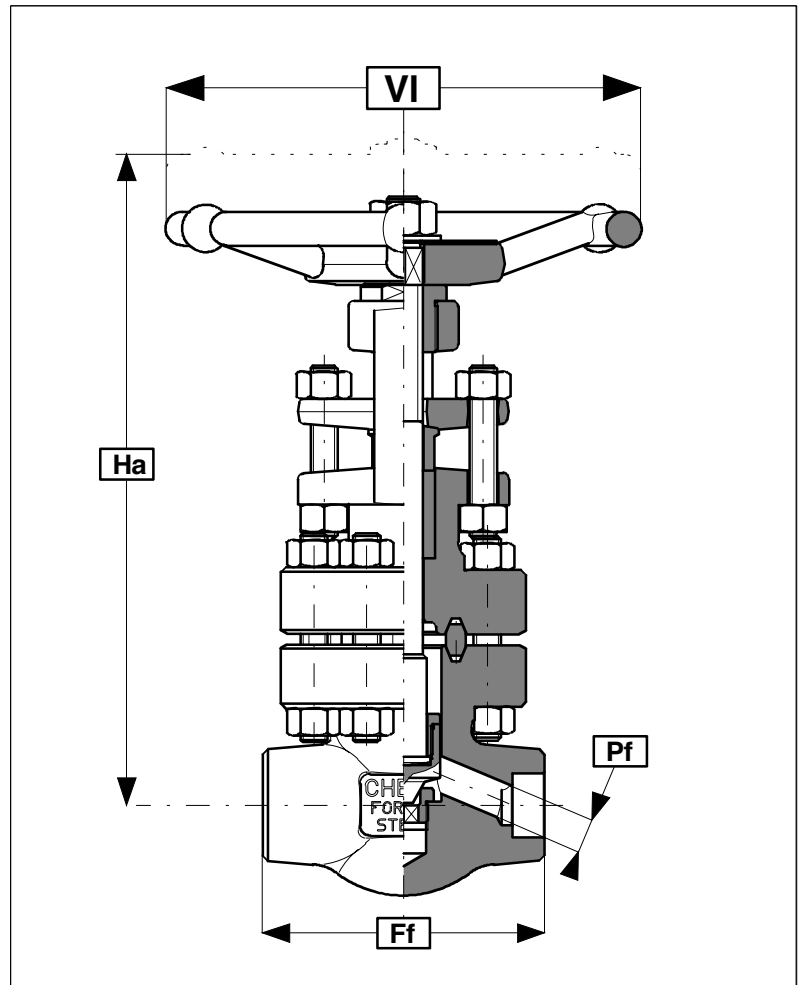
STANDARD BORE

		1/2"	3/4"	1"		1.1/2"	2"
Ff (mm/in)		110 4,33	115 4,52	130 5,12		210 8,27	240 9,45
Ha (mm/in)		218 8,58	260 10,24	268 10,55		427 16,81	433 17,05
VI (mm/in)		140 5,51	200 7,87	200 7,87		260 10,24	350 13,77
Pf (mm/in)		10 0,39	13 0,51	18 0,71		25 0,98	34 1,33
Wt. (kg/lb)		5,8 13,0	8,3 18,3	9,7 21,3		26,8 59,0	35,3 77,7
Catal. no.		1152/xx	1153/xx	1154/xx		1156/xx	1157/xx

1) Standard and alternative valve materials on page 67, type A
2) Complete Pressure-Temperature ratings on page 68, 69, 70,71,72
3) SW, NPT & BW dimensions on page 73

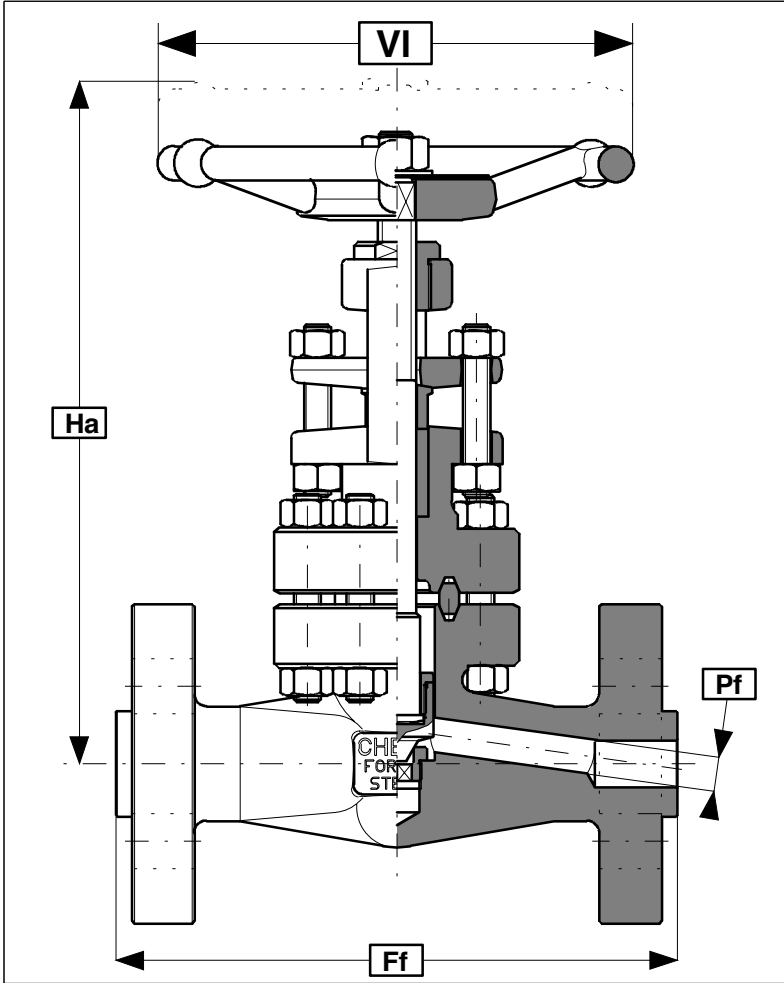

Ratings (ASTM A105)

2500 p.s.i. @ 850°F
6170 p.s.i. @ 100°F

Test pressure (ASTM A105)

Hydraulic: (minimum)
Body - 9275 p.s.i.
Seat - 6800 p.s.i.
Air under water:
Seat - 85 p.s.i.

Standards

Construction founded on ASME B16.34
Flanged ASME B16.5, ASME B16.10
Test API 598-ASME B16.34

Connections (xx)

RF	Raised face (std.)	LF	Large female
RJ	Ring joint	LG	Large groove
SF	Small female	LM	Large male
SG	Small groove	LT	Large tongue
SM	Small male		
ST	Small tongue		

STANDARD BORE

		1/2"		3/4"		1"		1.1/2"		2"	
Ff (mm/in)		263,5	10,37	273,0	10,75	308,0	12,13	384,2	15,13	450,8	17,15
Ha (mm/in)		218	8,58	274	10,79	286	11,26	427	16,81	433	17,05
VI (mm/in)		140	5,51	200	7,87	200	7,87	260	10,24	350	13,77
Pf (mm/in)		10	0,39	13	0,51	18	0,71	25	0,98	34	1,33
Wt. (kg/lb)		9,6	21,1	15,4	33,9	17,4	38,3	38,5	84,7	55,9	123,0
Catal. no.		1152/250xx		1153/250xx		1154/250xx		1156/250xx		1157/250xx	

1) Standard and alternative valve materials on page 67, type A
2) Complete Pressure-Temperature ratings on page 68, 69, 70,71,72
3) Flanges & face-to-face dimensions on page 74,75