

PTFE-LINED BUTTERFLY VALVE T 214-A

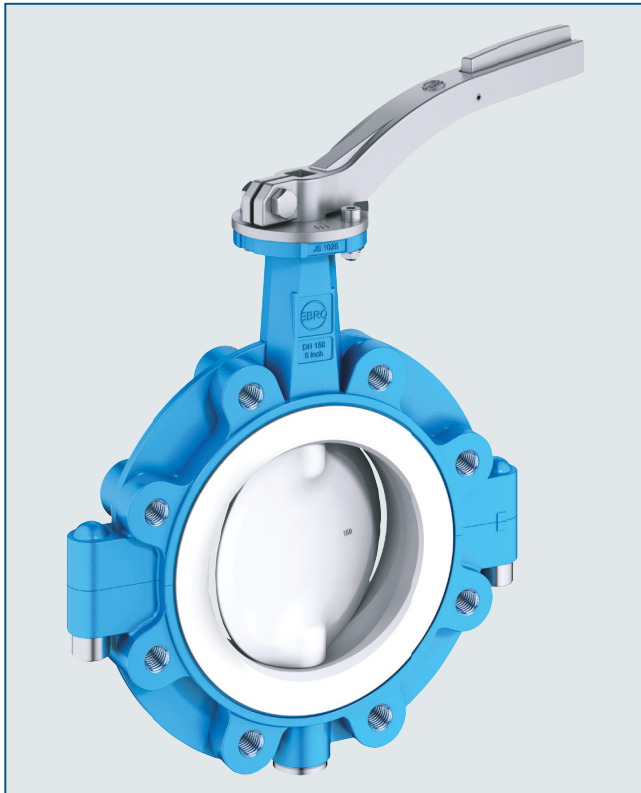

Lug type valve for corrosive and aggressive media. The patented shaft seal design ensures reliability even with high-corrosive applications.

TECHNICAL DATA

Nominal diameter:	DN(40) 50 - DN 300
Face-to-face:	EN 558 Series 20 ISO 5752 Series 20 API 609 Table 2
Flange accommodation:	EN 1092 PN 10/16 ASME Class 150 AS 4087
Flange Surface Design:	EN 1092 Form A/B ASME RF, FF
Top flange:	EN ISO 5211
Marking:	EN 19
Tightness check:	EN 12266 (Leakage rate A)
Temperature range:	-40°C to +200°C (depending on operation pressure)
Operating pressure:	max. 10 bar (16 bar for special version)
Vacuum:	up to 1 mbar absolute (with silicon elastomer inserts) from -10°C bis +160°C

FEATURES

- PTFE-lined butterfly valve for chemically toxic and highly corrosive media
- Environmental protection via EBRO-Safety seal
- Splitted body design
- Isolation height according to plant prescription
- Can be installed in any desired position
- Maintenance-free
- Can be disassembled, material-specific recycling possible
- Material conform to FDA to EG 1935/2004
- Optional: Special design RWTÜV certified to TA-Air/ VDI 2440

GENERAL APPLICATIONS

- Chemically highly corrosive and toxic media
- Purification plants
- Pharmaceutical industry
- Adhesives, paper industry, dissolver
- Paint manufacture and processing
- Food industry
- Chlorine production
- Processing of ore

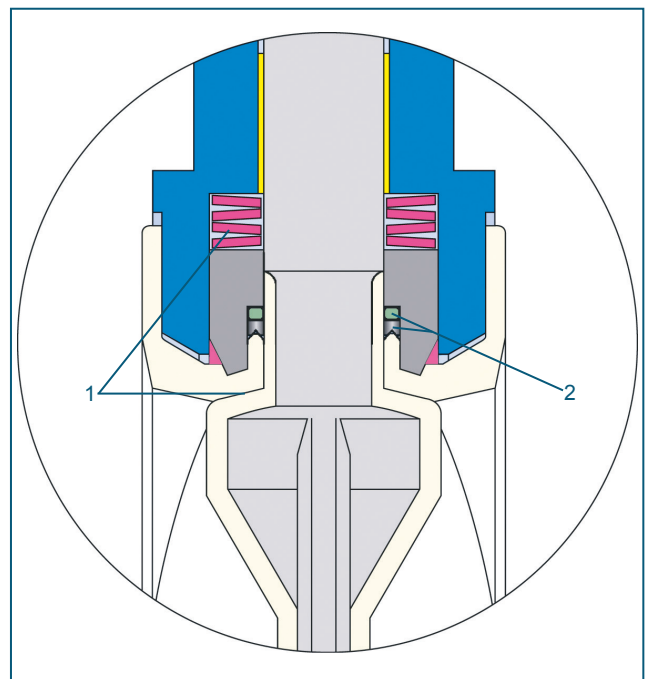

Safety seal at both shaft ends:

1. Primary sealing by means of a Belleville spring washer, transmitting prestress on the spherical segment area.
2. Secondary sealing of the shaft by means of PTFE-Chevron and o-ring.

PTFE-LINED BUTTERFLY VALVE T 214-A

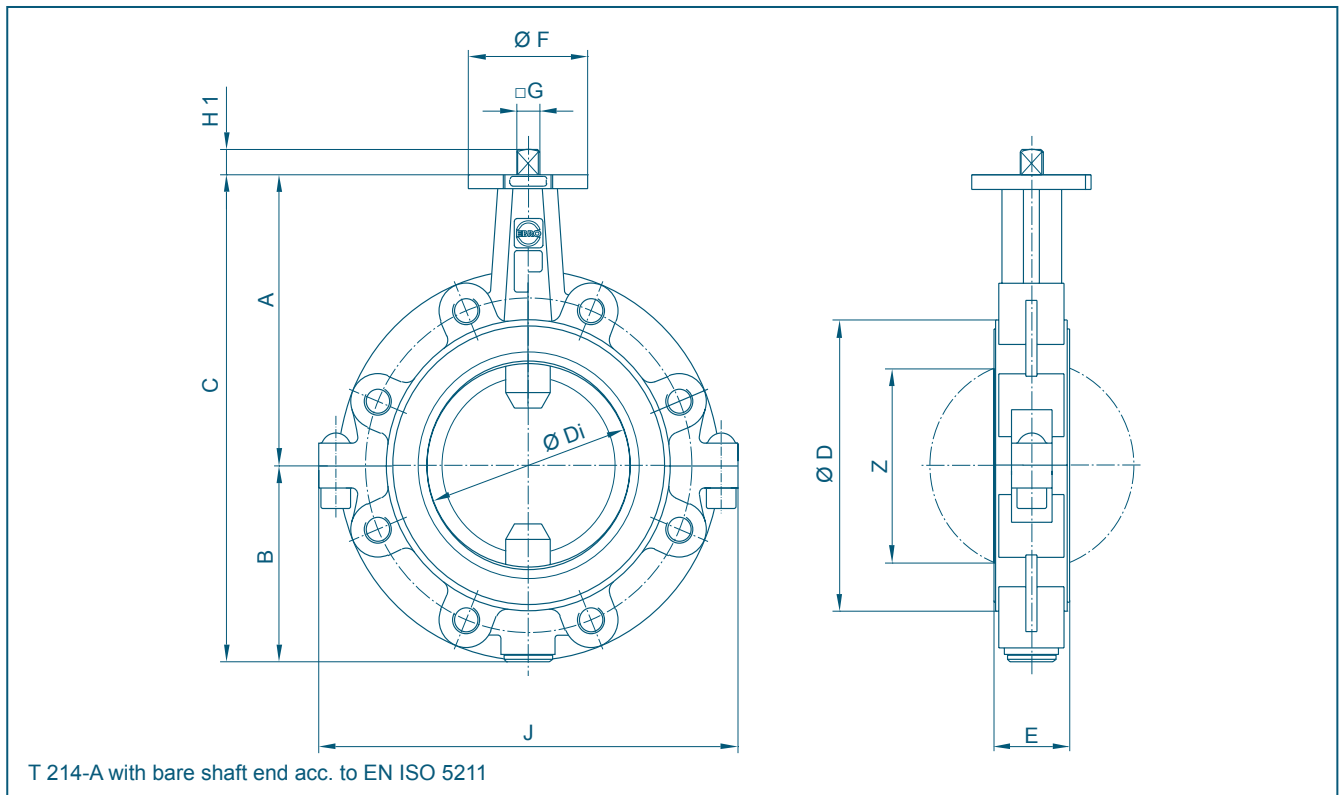

DN [mm]	Size [in]	Dimensions [mm]												Weight [kg]
		A	B	C	D	Di	E	F	Flange	G	H1	J	Z	
40*/50	2	135	80	215	104	60,8	46	54	F04	11	12	160	41	3,8
65	2½	150	82	232	104	60,8	46	54	F04	11	12	176	41	4,5
80	3	157	108	265	130	79,5	46	65	F05	14	16	230	66	6,2
100	4	180	118	298	160	99,0	52	65	F05	14	16	255	85	9,7
125	5	195	130	325	190	124,5	56	90	F07	17	19	290	112	12,0
150	6	210	142	352	210	150,5	56	90	F07	17	19	310	141	13,5
200	8	240	169	409	268	195,5	60	90	F07	17	19	390	187	22,0
250	10	275	217	492	324	247,5	68	125	F10	22	24	480	239	37,0
300	12	300	240	540	374	292,5	78	125	F10	22	24	550	283	55,0

*DN 50 drilled DN 40

Subject to change without notice

PTFE-LINED BUTTERFLY VALVE T 214-A

MATERIAL SPECIFICATION AND PARTS LIST

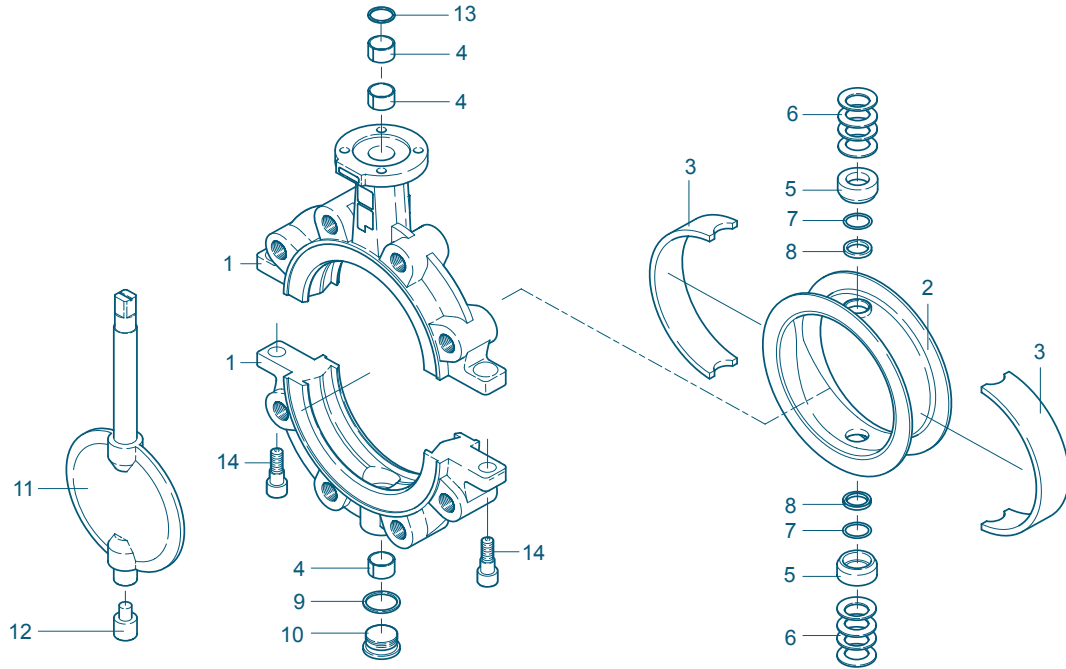

PTFE-lined butterfly valve DN 80 - DN 200

Pt.	Description	Material	Material-No.	ASTM	Pt.	Description	Material	Material-No.	ASTM
1	Body				9	Seal			
	Nodular Cast Iron	EN-JS 1025	EN 1563	A 395		Stainless Steel	X5CrNi18-10	1.4301	304
2**	Seat				10	Plug screw DIN 908			
	PTFE	Polytetrafluorethylene	PTFE	PTFE		Stainless Steel	G-X6CrNiMo18-10	1.4408	CF8M
	M.-PTFE	Polytetrafluorethylene	modified		11***	Disc/Shaft	one-piece		
	Cond.-PTFE	Polytetrafluorethylene	conductive			St.Steel/ St.Steel	G-X2CoNiMoN26-7-4	1.4469	Duplex
3**	Elastomer insert					St.Steel/ PTFE	G-X2CoNiMoN26-7-4	1.4469/	Duplex
	Silicon	Silicon rubber	MVQ	VMQ			Polytetrafluorethylene	PTFE	PTFE
4	DU-bearing					St.Steel/ M.-PTFE	G-X2CoNiMoN26-7-4	1.4469/	Duplex
	Steel / PTFE coated						Polytetrafluorethylene	modified	
5**	Trust collar					St.Steel/ Cond.-PTFE	G-X2CoNiMoN26-7-4	1.4469/	Duplex
	Stainless Steel	X5CrNiMo17-12-2	1.4401	316			Polytetrafluorethylene	conductive	
6	Bellev. spr. washer				12	Lower shaft stub			
	Stainless Steel	X12CrNi177	1.4568	631		Stainless Steel	X39CrMo17-1	1.4122	
7**	O-ring				13	Wiper ring			
	FPM	Fluorocarbon rubber	FPM	FKM		PTFE	Polytetrafluorethylene	PTFE	PTFE
8**	Chevron seal				14	Screw			
	PTFE	Polytetrafluorethylene	PTFE	PTFE		Stainless Steel	A4-70		
						Above-mentioned materials of the basic version, other materials upon request			

** recommended spare parts

*** recommended for coated discs

Subject to change without notice

PTFE-LINED BUTTERFLY VALVE T 214-A

TORQUE

- The torque values specified (Md) are based on dry media and are measured with air at a temperature of 20 °C
- The values specified are based on the initial breakaway torque (disc disengages from seat, torque then drops)
- Dynamic torque specification available upon request

Regarding the dimensioning of actuators, please contact our engineers.

PRESSURE/TEMPERATURE DIAGRAM

DN [mm]	40/50	65	80	100	125	150	200	250	300
Size [in]	2	2½	3	4	5	6	8	10	12
MD [Nm]	40	40	70	95	130	170	230	350	480

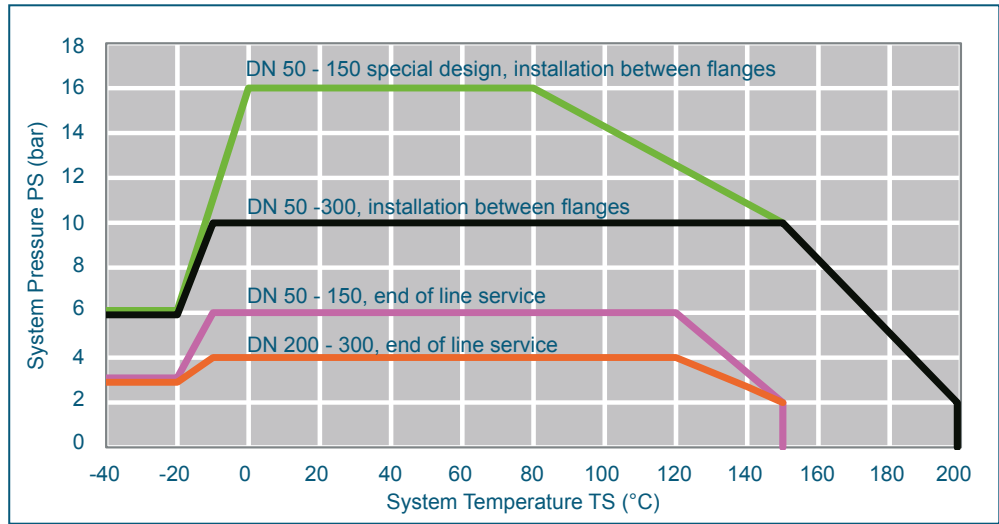

Pressure-Temperature-Diagramm for valves with Silicone elastomer inserts

Service limitation with EPDM elastomer inserts from -10°C up to +120°C

Service limitation with Fluor carbon inserts (FPM) from -10°C up to +180°C

Vacuum service to 1mbar absolute, from -10°C up to +160°C. Valve installation between flanges

K_v-VALUES

- The K_v-value [m³ per hour] is the flow of water at a temperature of 5°C to 30°C (41°F to 86°F) at Δp of 1 bar
- The K_v-values specified are based on tests carried out by the Delfter Hydraulics Laboratories, the Netherlands
- Permissible velocity of flow
V_{max} 4,5 m/s for liquids,
V_{max} 70 m/s for gases

- The throttle function is linear at an angle 30° to 70°

- Avoid cavitation

For further values, please contact our engineers.

DN [mm]	Size [in]	Opening angle α°							
		20°	30°	40°	50°	60°	70°	80°	90°
1) K_v-values metal-disc									
40/50	2	4	2	11	28	53	84	121	161
65	2½	5	8	25	56	99	153	216	287
80	3	13	12	30	69	131	216	328	467
100	4	13	25	61	121	207	319	459	627
125	5	37	66	122	216	353	543	793	1111
150	6	50	94	171	303	509	810	1226	1778
200	8	137	149	344	696	1178	1764	2426	3137
250	10	178	291	562	1021	1699	2626	3832	5348
300	12	395	378	820	1638	2751	4079	5538	7049
2) K_v-values PTFE-disc									
40/50	2	2	1	4	12	22	35	50	67
65	2½	3	9	26	48	74	98	117	126
80	3	4	14	38	71	108	143	171	186
100	4	6	16	48	95	151	209	262	303
125	5	12	40	110	217	356	525	718	933
150	6	18	60	161	317	526	787	1096	1452
200	8	125	176	395	756	1234	1807	2449	3136
250	10	138	333	644	1103	1744	2599	3702	5086
300	12	203	462	872	1479	2329	3471	4950	6814

Subject to change without notice