

HIGH PERFORMANCE BUTTERFLY VALVE HP 114-C

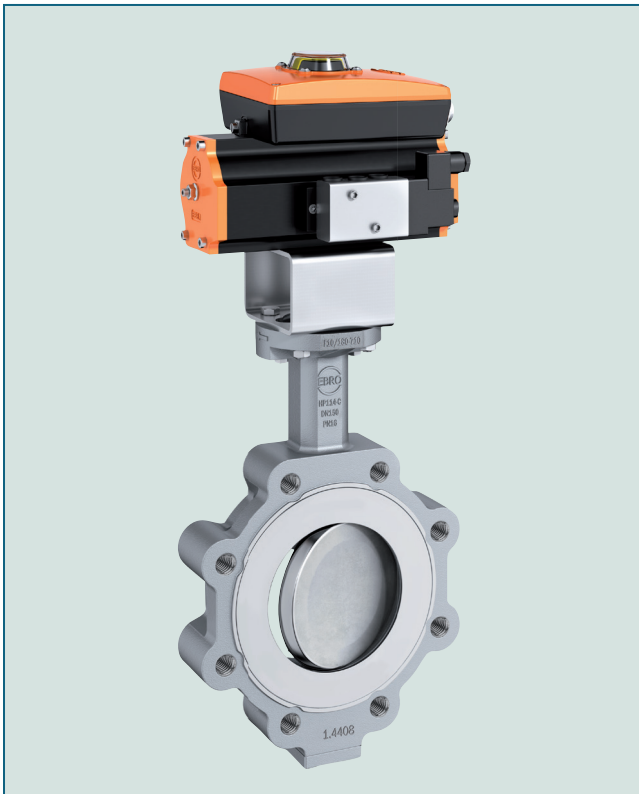

High Performance valve for the chemical industry.

TECHNICAL DATA

Nominal diameter:	DN 80 - DN 400
Face-to-face:	EN 558 Table 25
Design:	Lug type (optional: through holes)
Body:	1.0619 (WCB); 1.4408 (CF8M)
Temperature range:	-60°C to +230°C (R-PTFE-Seat) -60°C to +600°C (Inconel-Seat)
Nominal pressure:	max. 40 bar
Leakage rate:	R-PTFE, EN 12266, Leakage rate A Inconel, EN 12266, Leakage rate B
Flange drilling:	EN 1092 PN 10/16/25/40
Marking:	EN 19 PAS 1085 TA-Luft

Valve Design
acc. to PAS 1085

FEATURES

- Plane sealing surface without interference (groove acc. to EN 1092 optional)
- Clamping ring without bore holes
- Long valve neck (for complete isolation)
- Distortion stop outside of media flow
- Integrated gland flange
- Quick and easy mounting
- Can be installed in any desired position
- Maintenance-free
- Integrated primary shaft seal
- Firesafe API Standard 607 - 7th edition, ISO 10497-5: 2010

GENERAL APPLICATIONS

- Chemical and petrochemical Industry
- Heavy-Duty applications

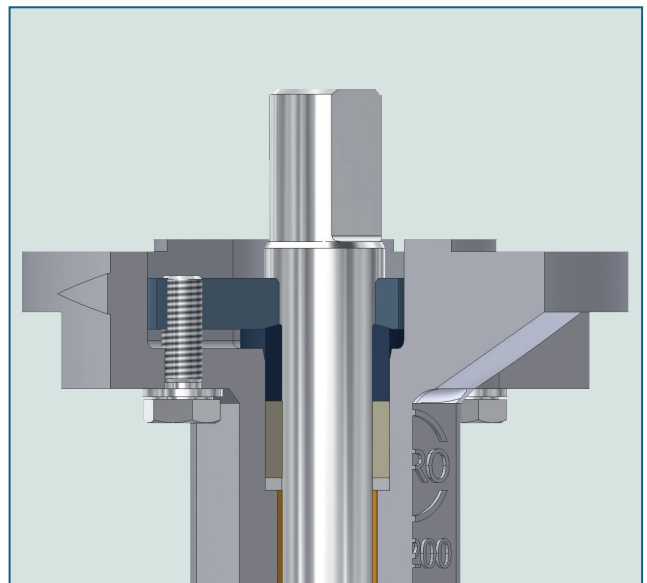

Gland flange integrated in top flange.

HIGH PERFORMANCE BUTTERFLY VALVE HP 114-C

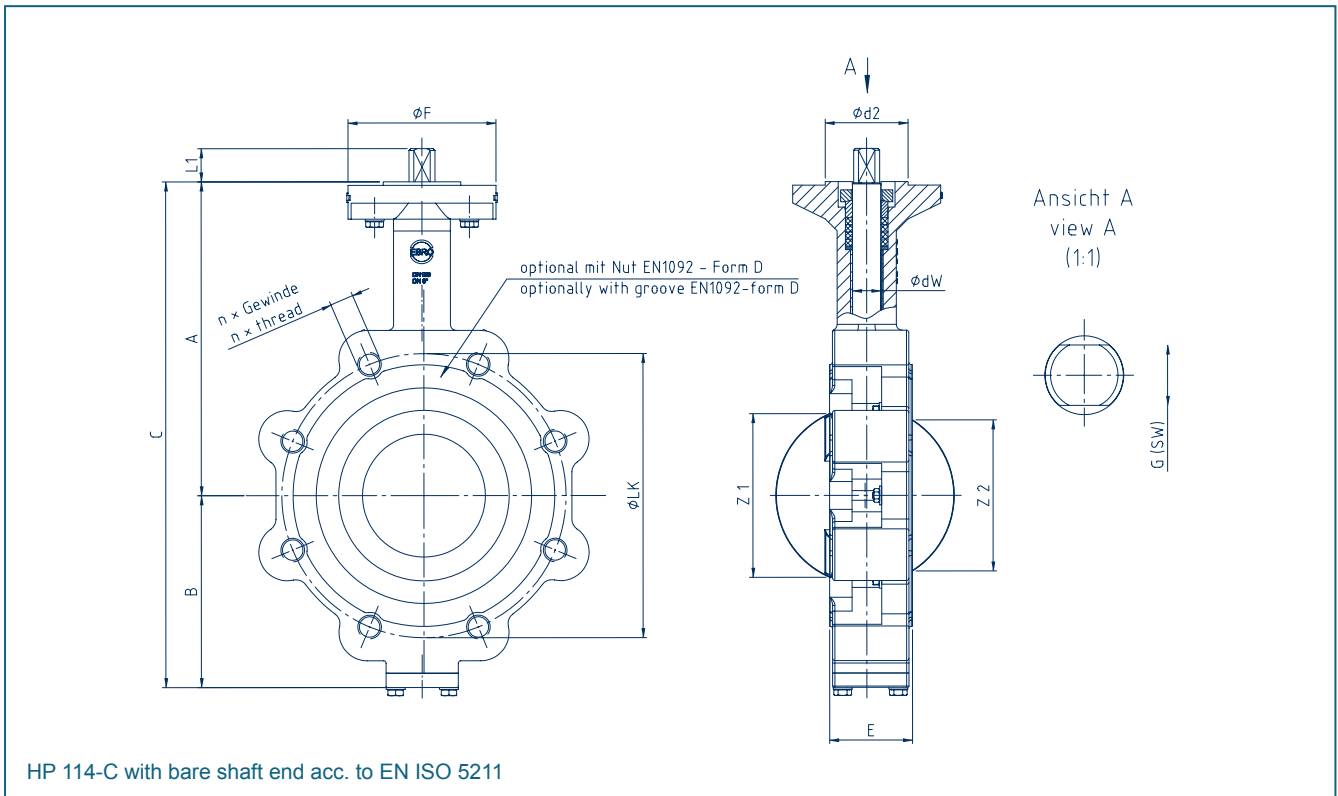

DN [mm]	Size [in]	Dimensions [mm]														Weight [kg]	
		ØdW	A	B	C	E	ØLK	n	Thread	Z1	Z2	Flange	ØF	Ød2	G		L1
80	3	20	210	110	320	49	160	8	M16	72	46	F 07	90	55	14	23,5	8,5
100	4	20	225	131	356	56	180	8	M16	95	77	F 07	90	55	14	23,5	11,5
150	6	24	265	162	427	70	240	8	M20	139	128	F 10	125	70	17	28,0	23,0
200	8	30	310	200	510	71	295	12	M20	185	176	F 12	150	85	22	37,0	39,5
250	10	36	360	240	600	76	355	12	M24	235	225	F 14	175	100	27	46,0	53,0
300	12	42	401	275	676	83	410	12	M24	281	273	F 14/16*	175	100	27	46,0	69,0
350	14	42	435	310	745	92	470	16	M24	324	315	F 16	210	130	27	46,0	92,0
400	16	50	476	350	826	102	525	16	M27	373	363	F 16/25*	210	130	36	61,5	132,0

* for PN 25/40 DN 300 = F16
DN 400 = F25

Subject to change without notice

HIGH PERFORMANCE BUTTERFLY VALVE HP 114-C

MATERIAL SPECIFICATION AND PARTS LIST

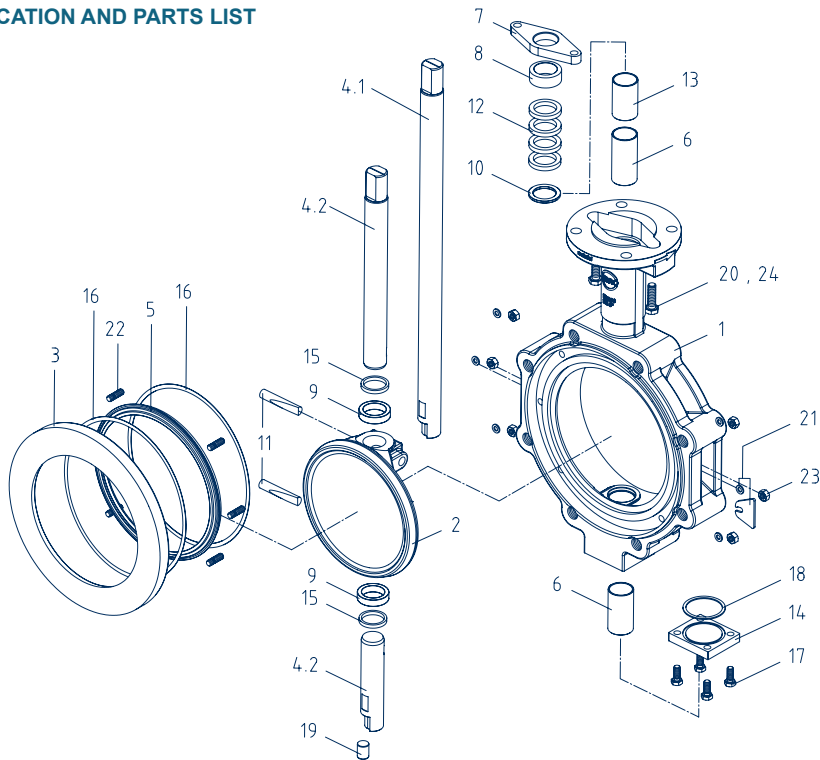

Pos.	Description	Material	Material-No.	ASTM	Pos.	Description	Material	Material-No.	ASTM
1	Body				12	Seal			
	Carbon Steel	GP240GH	1.0619	A216 WCB		Graphite			
	Stainless Steel	GX5CrNiMo 19-11-2	1.4408	A351 CF8M		PTFE			
2	Disc				13	Spacer sleeve			
	Stainless Steel	GX5CrNiMo 19-11-2	1.4408	A351 CF8M		Stainless Steel	X6CrNiMoTi 17-12-2	1.4571	316 Ti
3	Clamping ring				14	Cover plate			
	Steel	S235JR+N	1.0038+N			Stainless Steel	X8CrNiS 18-9	1.4305	304
	Stainless Steel	GX5CrNiMo 19-11-2	1.4408	A351 CF8M		Stainless Steel	X5CrNiS 18-10	1.4301	304
	Stainless Steel	X2CrNiMo 17-12-2	1.4404	316 L	15	Turcon-Variseal-M2			
4.1	Through shaft (TS-version)					PTFE / Metal spring			
	Stainless Steel	X5CrNiCuNb 16-4	1.4542	630	16	Graphite seal			
4.2	Splitted shaft					Graphite			
	Stainless Steel (< 300°C)	X4CrNiMo16-5-1	1.4418		17	Hex. bolt			
	Stainless Steel (> 300°C)	X6NiCrTiMoVB 25-15-2	1.4980			Stainless Steel	A4-70		B 8 M
	Stainless Steel	X5CrNiCuNb16-4	1.4542		18	Seal			
5	Seat ring					Graphite			
	R-PTFE	PTFE-Compound				PTFE			
	Inconel	Inconel 625			19	Taper pin / distertion stop			
6	Shaft bearing					Stainless Steel	X5CrNiCuNb 16-4	1.4542	630
	Stainless Steel	X5CrNiMo 17-12-2	1.4401 / PTFE	316 PTFE		Stainless Steel	X4CrNiMo 16-5-1	1.4418	431
	Stainless Steel	X6CrNiMoTi 17-12-2	1.4571 nitrite	316 Ti	20	Hex. bolt			
7	Gland flange					Stainless Steel	A4-70		B 8 M
	Stainless Steel	GX2CrNiMoN 26-7-4	1.4469	A995	21	Washer			
	Stainless Steel	X2CrNiMoN 22-5-3	1.4462	F51		Stainless Steel	A4		8
8	Thrust collar					Stainless Steel	X6CrNiMoTi 17-12-2	1.4571	316 Ti
	Stainless Steel	X8CrNiS 18-9	1.4305	304	22	Threaded pin			
	Stainless Steel	X5CrNiS 18-10	1.4301	304		Stainless Steel	A4-70		B 8 M
9	Bearing ring				23	Hex. nut			
	Stainless Steel	X6CrNiMoTi 17-12-2	1.4571 chr-pld	316 Ti		Stainless Steel	A4-70		B 8 M
10	Suppor. washer								
	Stainless Steel	X6CrNiMoTi 17-12-2	1.4571	316 Ti					
11	Taper pin								
	Stainless Steel	X5CrNiCuNb 16-4	1.4542	630					
	Stainless Steel	X4CrNiMo 16-5-1	1.4418	431					

Subject to change without notice

HIGH PERFORMANCE BUTTERFLY VALVE HP 114-C

TORQUE

- The values specified are based on the initial breakaway torque. (disc disengages from seat, torque then drops)

DN [mm]	Size [in]	Operating pressure							
		10 [bar]		16 [bar]		25 [bar]		40 [bar]	
		R-PTFE	Inconel	R-PTFE	Inconel	R-PTFE	Inconel	R-PTFE	Inconel
80	3	28	55	30	65	34	90	38	100
100	4	51	90	61	100	80	120	95	140
150	6	125	170	136	220	168	300	220*	360*
200	8	205	350	260	430	280	505	315*	630*
250	10	485	505	550	620	600	860	685*	1260*
300	12	584	740	700	970	855	1280	1115*	1800*
350	14	740	815	930	1050	1200	1370	1650*	1900*
400	16	1150	1530	1640	2240	2460	2900	3830*	4000*

* with through shaft only (TS-version)

All values in Nm

K_V-VALUES

- The K_V-value [m³ per hour] is the flow of water at a temperature of 5°C to 30°C (41°F to 86°F) at Δp of 1 bar

- The K_V-values specified are based on tests carried out by the Delfter Hydraulics Laboratories, the Netherlands

- Permissible velocity of flow
V_{max} 4,5 m/s for liquids,
V_{max} 70 m/s for gases

- The throttle function is linear at an angle 30° to 70°

- Avoid cavitation!

For further values, please contact our engineers.

DN [mm]	Size [in]	Opening angle α° HP-C splitted shaft (PN 10 - PN 25)							
		20°	30°	40°	50°	60°	70°	80°	90°
80	3	20	41	65	91	110	132	150	156
100	4	24	41	78	118	183	241	287	323
150	6	88	150	215	320	475	638	815	845
200	8	194	286	434	662	955	1335	1666	1712
250	10	255	430	620	924	1369	1852	2344	2430
300	12	429	632	930	1413	2052	2870	3622	3788
350	14	565	942	1410	2076	2916	3876	4751	4989
400	16	708	1185	1772	2683	3888	5279	6812	6977

DN [mm]	Size [in]	Opening angle α° HP-C through shaft (PN 40)							
		20°	30°	40°	50°	60°	70°	80°	90°
80*	3	20	41	65	91	110	132	150	156
100*	4	24	41	78	118	183	241	287	323
150	6	80	170	257	345	463	587	722	757
200	8	179	307	444	643	907	1210	1440	1460
250	10	233	390	570	850	1260	1700	2150	2230
300	12	370	620	890	1330	1970	2670	3380	3500
350	14	534	890	1349	1968	2769	3735	4550	4750
400	16	690	1160	1670	2500	3700	5012	6340	6580

* splitted shaft only

Subject to change without notice