

HIGH PERFORMANCE BUTTERFLY VALVE HP 112

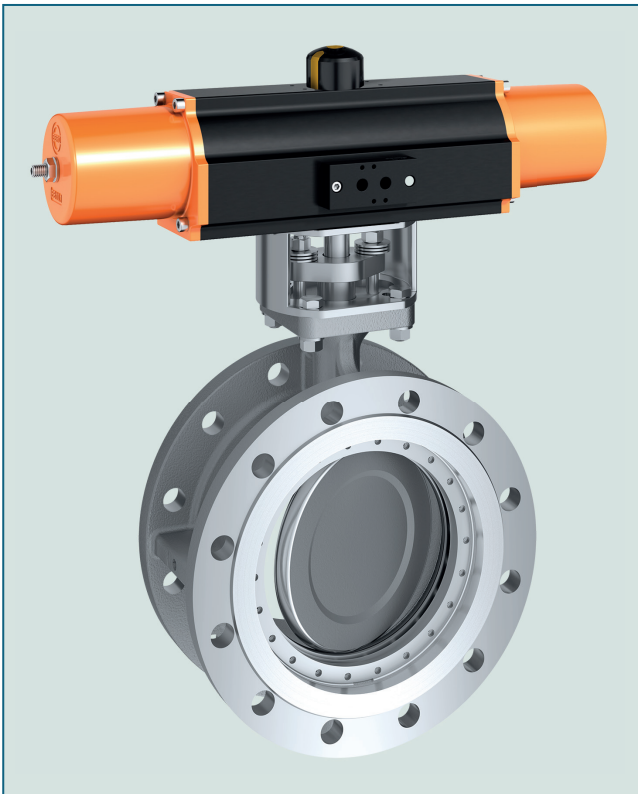

Double-flanged butterfly valve in double-eccentric construction. Reliable sealing even with extreme temperature and pressure conditions.

TECHNICAL DATA

Nominal diameter:	DN 80 - DN 600
Face-to-face:	EN 558 Series 13 others upon request
Flange accommodation:	EN 1092 PN 10/16/25/40 ASME Class 150 AS 4087 PN 16/21
Flange Surface Design:	EN 1092 Form A/B ASME RF, FF
Marking:	EN 19
Tightness check	
- for R-PTFE seat:	EN 12266 (Leakage rate A)
- for Inconel seat:	EN 12266 (Leakage rate B) ISO 5208, Category 3
Temperature range:	-60°C up to +300°C
Operating pressure:	≤ DN 150, 40 bar > DN 150, 25 bar
Vacuum:	up to 1mbar absolute

FEATURES

- Shut-off and control valve for gaseous and liquid media
- Disc has double-eccentric bearing
- Seat ring systems available: R-PTFE, Inconel and Fire Safe
- Maintenance-free
- Long service life, even at high switching frequencies
- Seat variants:
 - soft seating (R-PTFE) max. 230°C
 - metallic seating (Inconel) max. 300°C
 - fire safe (PTFE / Inconel) max. 200°C
- Firesafe API Standard 607 - 7th edition, ISO 10497-5: 2010

GENERAL APPLICATIONS:

- Chemical and petrochemical industry
- Hot water and steam systems
- District heat supply
- Vacuum systems
- Shipbuilding
- Gas process technology
- Heavy duty services

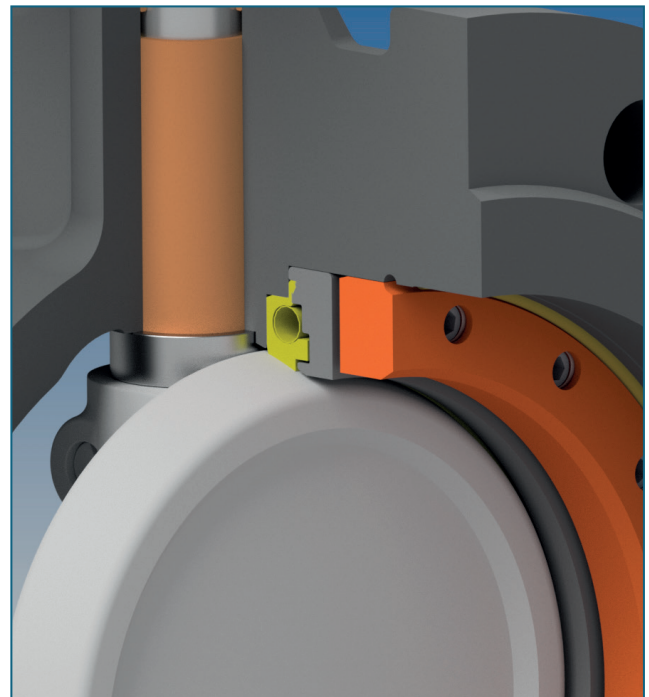

Sealing system with inside R-PTFE thrust collar.

HIGH PERFORMANCE BUTTERFLY VALVE HP 112

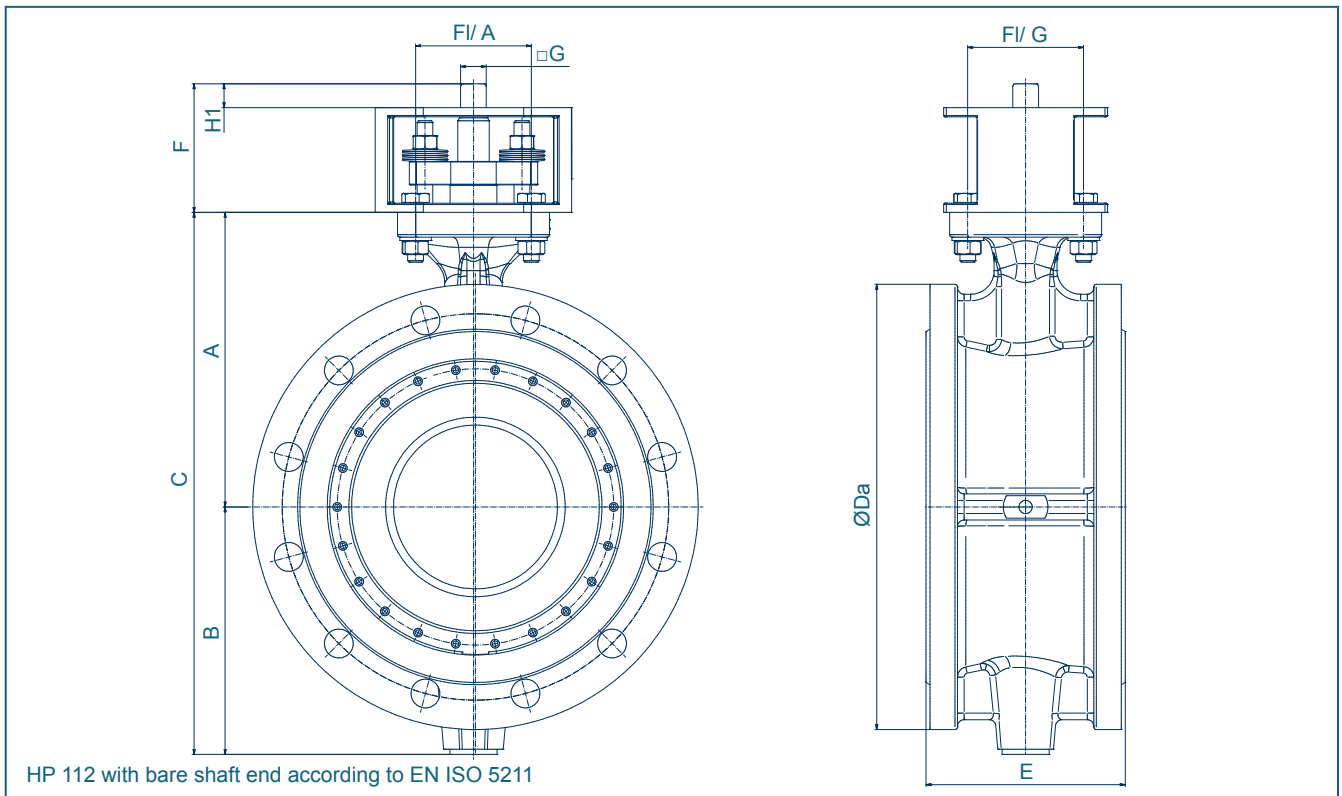

DN [mm]	Size [in]	Pressure Rating	Dimensions [mm]										Weight [kg]
			A	B	C	ØDa	E	F	FI/A	FI/G	cG	H1	
80	3	PN10, PN16, PN25, PN40, cl.150	142,0	109,5	251,5	191,0	114,0	95,2	F05/F07	F07	12	15,2	14,50
100	4	PN10, PN16, cl.150 PN25, PN40	158,0	122,0	280,0	229,0	127,0	95,0	F05/F07	F07	12	14,972	19,00
						254,0							22,10
125	5	PN10, PN16 PN25, PN40 cl.150	181,0	138,0	319,0	250,0	140,0	98,2	F07/F10	F10	14	18,2	23,0
						270,0							27,4
150	6	PN10, PN16 PN25, PN40 cl.150	195,0	152,0	347,0	254,0	140,0	98,0	F07/F10	F10	14	18,0	25,8
						285,0							27,7
200	8	PN10, PN16, cl.150 PN25	225,0	189,0	414,0	300,0	152,0	98,0	F10/F12	F12	17	18,0	33,6
						343,0							30,7
250	10	PN10, PN16 PN25 cl.150	268,0	220,0	488,0	405,0	165,0	103,15	F10/F12	F12	22	23,15	48,6
						425,0							61,3
300	12	PN10 PN16 PN25 cl.150	300,0	259,0	559,0	406,0	178,0	118,0	F12	F14	27,0	28,0	68,6
						445,0							80,5
350	14	PN10 PN16 PN25 cl.150	345,0	304,0	649,0	460,0	190,0	127,75	F14	F14	27,0	27,75	84,1
						485,0							99,3
400	16	PN10 PN16 PN25 cl.150	379,0	339,0	718,0	505,0	216,0	132,0	F14	F16	36,0	36,0	103,7
						520,0							119,2
450	18	PN10 PN16 cl.150	416,0	366,0	782,0	533,0	222,0	152,0	F16	F16	36,0	36,0	123,4
						555,0							149,1
500	20	PN10 PN16 PN25 cl.150	445,0	399,0	844,0	580,0	229,0	162,0	F16	F16	46,0	46,0	167,2
						620,0							166,4
600	24	PN10 PN16 PN25 cl.150	528,0	468,0	996,0	597,0	267,0	196,0	F25	F25	55,0	55,0	199,7
						615,0							187,2
						670,0							226,2
						698,0							299,4
						780,0							297,4
						813,0							281,6
													359,0
													482,5
													479,1
													452,3

HIGH PERFORMANCE BUTTERFLY VALVE HP 112

MATERIAL SPECIFICATION AND PARTS LIST

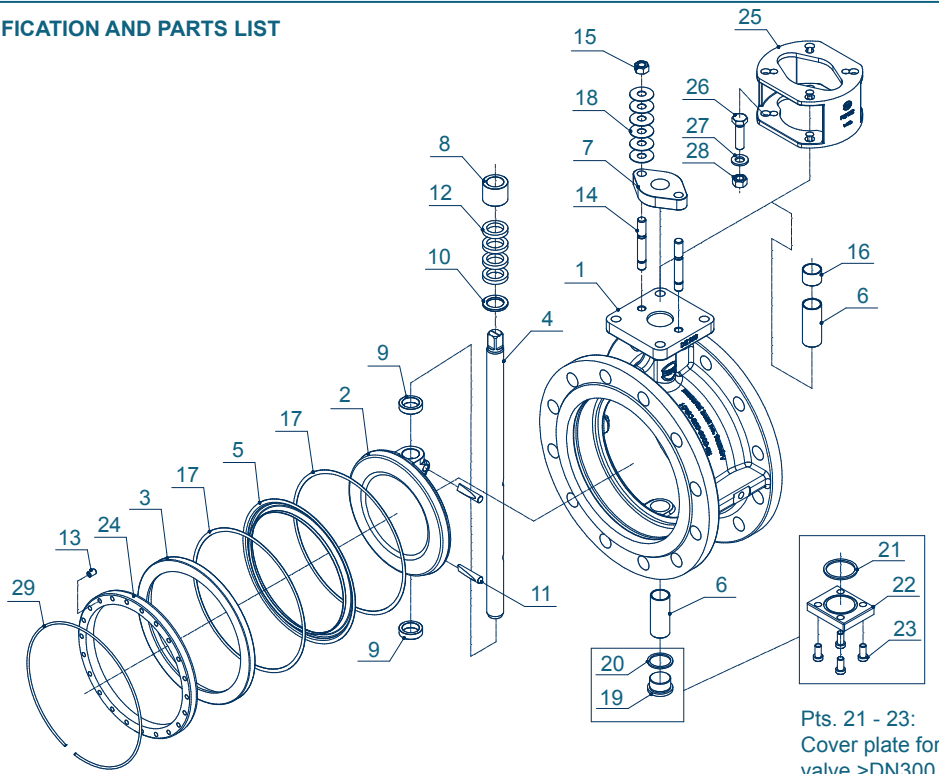

Pos.	Description	Material	Material-No.	ASTM	Pos.	Description	Material	Material-No.	ASTM			
1	Body	Carbon Steel	GP240GH	1.0619	14	Threaded pin	Stainless steel	A4-70	B 8 M			
		Stainless Steel	G-X5CrNiMo19-11-2	1.4408			15	Hex.-nut	Stainless steel	A4-70	B 8 M	
2	Disc	Stainless Steel	G-X5CrNiMo19-11-2	1.4408	16	Spacer sleeve	Stainless steel		X6CrNiMoTi17-12-2	1.4571		
		Duplex	GX2CrNiMoN26-7-4	1.4469	17		Graphite seal (for metal seat)	Graphite				
3	Clamping ring	Steel	S235JR+N	1.0038+N	18	Belleville spr. washer		50CrV4	1.4310			
		Stainless Steel	X2CrNiMo17-12-2	1.4404			316 L	19	Plug screw	Stainless steel	A2-50	B 8 M
		Stainless Steel	X6CrNiMoTi17-12-2	1.4571			316 Ti			20/21*	Seal	Machining steel
4	Shaft	Stainless Steel (< 300°C)	X4CrNiMo16-5-1	1.4418	22	Cover plate	Stainless steel	X5CrNiMo17-12-2	1.4401	304		
		Stainless Steel	X6CrNiMoTi17-12-2	1.4571 ni-pld			316 Ti	23	Hex.-socket screw	Stainless steel	G-X5CrNiMo19-11-2	1.4408
5	Seat ring	R-PTFE	PTFE-Compound		24	Support ring	Stainless steel	X6CrNiMoTi17-12-2		1.4571	316 Ti	
		Inconel	Inconel 625				25	Bracket	Steel	S235JR+N	1.0038+N	
6	Shaft bearing	Stainless Steel	X5CrNiMo17-12-2	1.4401/PTFE	316 PTFE	26	Hex. bolt		Steel	St galvanized		
		Stainless Steel	X6CrNiMoTi17-12-2	1.4571 ni-pld	316 Ti			27	Washer	Stainless steel	A2-70	B 8
7	Gland flange	Stainless steel	G-X5CrNiMo19-11-2	1.4408	CF8M	28	Hex. nut	Steel		St galvanized		
		Stainless Steel	X5CrNiMo17-12-2	1.4401	304			29	Snap ring	Stainless steel	A4	8
8	Thrust collar	Stainless Steel	X2CrNiMo17-12-2	1.4404	304	28	Hex. nut	Steel		St galvanized		
		Stainless Steel	X6CrNiMoTi17-12-2	1.4571	316 Ti			29	Snap ring	Stainless steel	A2-70	8
9	Bearing ring	Stainless steel	X6CrNiMoTi17-12-2	1.4571 chr-pld.	316 Ti	29	Snap ring				1.4310	
		Stainless steel	X2CrNiMoN22-5-3	1.4462 chr-pld						Inconel X750		
10	Support washer	Stainless steel	X6CrNiMoTi17-12-2	1.4571	316 Ti							
		Stainless steel	X4CrNiMo16-5-1	1.4418								
11	Taper pin	Stainless steel	X4CrNiMo16-5-1	1.4418								
		Graphite										
12	Shaft seal	PTFE										
		Stainless steel	A4-70		B 8 M							
13	Hex. socket screw	Stainless steel	A4-70		B 8 M							
			X1NiCrMoCuN25-20-7	1.4529								

Other materials upon request.

Subject to change without notice

HIGH PERFORMANCE BUTTERFLY VALVE HP 112

TORQUE

- The values specified are based on the initial breakaway torque. (disc disengages from seat, torque then drops)

DN [mm]	Size [in]	Operating pressure							
		10 [bar]		16 [bar]		25 [bar]		40 [bar]	
		R-PTFE	Inconel	R-PTFE	Inconel	R-PTFE	Inconel	R-PTFE	Inconel
80	3	28	55	30	65	34	90	38	100
100	4	51	90	61	100	80	120	93	140
125	5	63	150	83	172	95	220	125	285
150	6	125	170	136	220	168	300	220	360
200	8	205	350	260	430	280	505	-	-
250	10	485	505	550	620	600	860	-	-
300	12	584	740	700	970	855	1280	-	-
350	14	740	815	930	1050	1200	1370	-	-
400	16	1150	1530	1640	2240	2460	2900	-	-
450	18	1150	1700	1750	2500	2700	3500	-	-
500	20	1210	2010	1800	2760	2800	4260	-	-
600	24	4000	4500	4600	5740	6200	8080	-	-

All values in Nm

PRESSURE/TEMPERATURE DIAGRAM

- Pressure control line for 1.0619 body material and metal seat
- Pressure control line for 1.4408 body material and metal seat
- - - Pressure control line for R-PTFE

The diagram illustrates the performance of the standard version of our valve type HP. Valves for higher pressure or deviating temperature are available upon request.

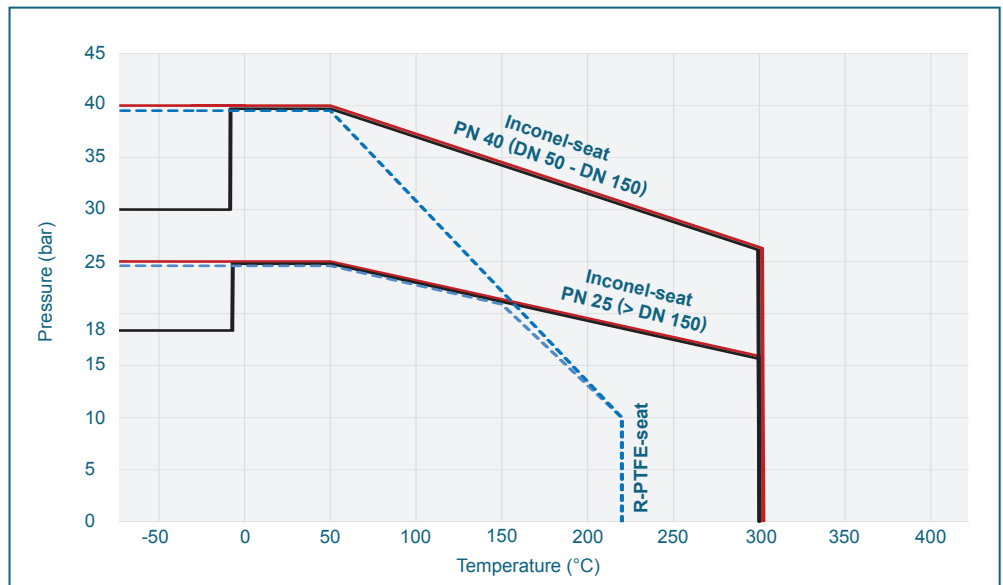

K_V-VALUES

- The K_V-values [m³ per hour] is the flow of water at a temperature of 5°C to 30°C (41°F to 86°F) at Δp of 1 bar

- The K_V-values specified are based on tests carried out by the Delfter Hydraulics Laboratories, the Netherlands

- Permissible velocity of flow
V_{max} 4,5 m/s for liquids,
V_{max} 70 m/s for gases

- The throttle function is linear at an angle 30° to 70°

- Avoid cavitation

DN [mm]	Size [in]	Opening angle α°							
		20°	30°	40°	50°	60°	70°	80°	90°
80	3	7	30	50	68	82	97	113	115
100	4	22	60	97	119	164	199	223	251
125	5	45	100	152	195	256	346	452	493
150	6	63	109	162	250	391	588	814	845
200	8	96	168	301	509	742	1107	1581	1747
250	10	264	458	682	980	1421	2083	2882	2889
300	12	397	625	956	1368	1938	2778	3794	3940
350	14	460	720	1100	1650	2500	3400	4800	5400
400	16	550	870	1250	2000	3200	4800	6800	8080
450	18	730	1200	1800	3100	4600	6400	8400	10500
500	20	920	1600	2600	4100	6000	8500	12100	12800
600	24	1370	2250	3780	4950	9000	12500	17100	18500

Subject to change without notice

For further values, please contact our engineers.



www.ebro-armaturen.com
post@ebro-armaturen.com

06.2020