

General Information

Applications

- Pipeline main valves
- Manifolds
- Storage tanks
- Pig launchers and receivers
- Station valves
- Oil and gas transmission
- Distribution industry

Product Range

Size, in [mm]	ASME Class					
	150	300	400	600	900	1500
4 [100]	•	•	•	•	•	•
6 [150]	•	•	•	•	•	•
8 [200]	•	•	•	•	•	•
10 [250]	•	•	•	•	•	•
12 [300]	•	•	•	•	•	•
14 [350]	•	•	•	•	•	•
16 [400]	•	•	•	•	•	•
18 [450]	•	•	•	•	•	•
20 [500]	•	•	•	•	•	•
22 [550]	•	•	•	•	•	•
24 [600]	•	•	•	•	•	•
26 [650]	•	•	•	•	•	
28 [700]	•	•	•	•	•	
30 [750]	•	•	•	•	•	
32 [800]	•	•	•	•	•	
34 [850]	•	•	•	•	•	
36 [900]	•	•	•	•	•	
38 [950]	•	•	•	•		
40 [1,000]	•	•	•	•		
42 [1,050]	•	•	•	•		
48 [1,200]	•	•	•	•		
54 [1,300]	•	•	•	•		
58 [1,450]	•	•	•	•		
60 [1,500]	•	•	•	•		

Standard design features

- Stem seals with self-energized nonrolling lip seals
- No side load and friction drag on the stem—low operating thrust
- Stem protector and gate position indicator
- Through-conduit, self-cleaning, floating slab gate
- Floating seat always in contact with the gate
- Metal-to-metal primary seal; protected O-ring secondary seal
- Block-and-bleed and double block-and-bleed design
- Top-entry body for inline maintenance
- API Spec 6D standard
- Fabricated body construction
- Flexible product design arrangements

Optional features

- Built-in sealant injection system for emergency sealing
- Reverse-acting gate
- Graphite packing fire-safe sealing
- Outside screw and yoke (OS&Y) bonnet design
- Back seat
- Seat skirts for dirty fluid application
- Metal-to-metal with tungsten carbide coating (TCC)

Material Specifications

Materials selection

The following is a typical listing of materials for ASME Classes 150 to 1500 valves for standard applications.

Standard Models and Materials

Body	EN 10025 Grade Fe-510
	EN 10028 Grade P355NL2
Bonnet	EN 10025 Grade Fe-510
	EN 10028 Grade P355NL2
Stem	AISI 4140 (electroless nickel plating [ENP])
Bolting	A193 B7, A194 2H, A193 B7M, A194 2HM
	A320 L7, A194 Grade 7, A320 L7M, A194 Grade 7M

Internal Parts

Gate	EN 10025 Grade Fe-510
	EN 10028 Grade P355NL2
Seats	A105, A350 LF2
Springs	AISI 302, INCONEL® (different grades), Elgiloy®

Sealing Materials

Stem gaskets	Nitrile rubber
	FKM fluoroelastomer (Viton® different grades)
	Hydrogenated nitrile rubber
	Graphite packing (for OS&Y bonnet)
Seat and bonnet gaskets	Nitrile rubber
	FKM fluoroelastomer (Viton different grades)
	Hydrogenated nitrile rubber

Plating and Coating

0.001 in	25 µm
	ENP
0.003 in	75 µm
	ENP

NACE Requirements

On request	G4N gate valves are supplied fully in accordance with NACE MR0175
------------	---

Dimensions and Weights

ASME Class 600 Sizes 4–60 in [100–1,500 mm]

Larger on request. Reduced-bore valves also are available.

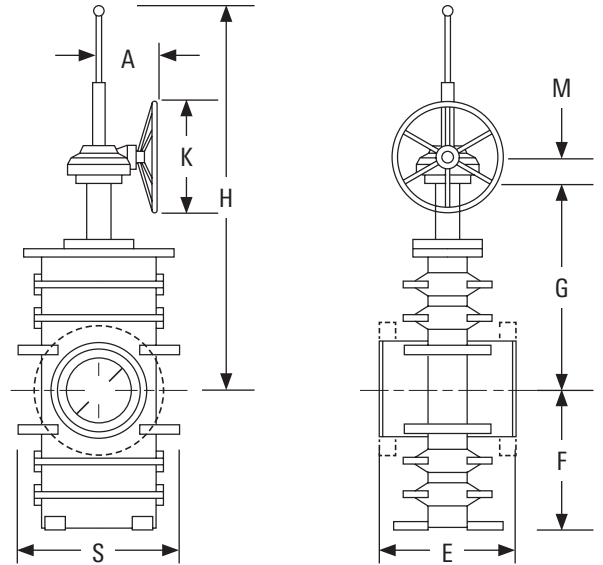

Size, in [mm]	D	E			F	G	S	H	A	K	M	Weight, lbm [kg]	
		WE	RF	RTJ								WE	RF/RTJ
4 [100]	4 [102]	17 [432]	17 [432]	17½ [435]	10¾ [277]	20% [524]	9¼ [242]	35% [911]	7% [200]	11¼ [300]	2¼ [56]	595 [270]	661 [300]
6 [150]	6 [152]	22 [559]	22 [559]	22½ [562]	13¾ [339]	25¾ [654]	14% [358]	44% [1,126]	7% [200]	11¼ [300]	2¼ [56]	683 [310]	844 [380]
8 [200]	8 [203]	26 [660]	26 [660]	26% [664]	16½ [420]	32% [822]	16¼ [414]	55% [1,405]	7% [200]	11¼ [300]	2¼ [56]	1,162 [527]	1,119 [508]
10 [250]	10 [254]	31 [787]	31 [787]	31% [791]	19% [499]	37¾ [960]	21½ [546]	65½ [1,663]	8% [225]	19¾ [300]	2¼ [56]	1,786 [810]	1,984 [900]
12 [300]	12 [305]	33 [838]	33 [838]	33% [841]	22½ [570]	43¾ [1,111]	25% [644]	75% [1,921]	8% [225]	19¾ [500]	2¼ [56]	2,519 [1,143]	2,646 [1,200]
14 [350]	13¼ [337]	35 [889]	35 [889]	35% [892]	24% [618]	46¼ [1,176]	28% [714]	81% [2,062]	9% [241]	19¾ [500]	3¼ [74]	2,698 [1,224]	2,998 [1,360]
16 [400]	15¼ [387]	39 [991]	39 [991]	39% [994]	27% [709]	52% [1,329]	31% [802]	91% [2,333]	12% [320]	19¾ [500]	4¼ [108]	4,474 [2,030]	4,971 [2,255]
18 [450]	17¼ [438]	43 [1,092]	43 [1,092]	43½ [1,095]	31% [789]	58% [1,484]	34¾ [882]	102% [2,601]	12% [320]	19¾ [500]	4¼ [108]	5,754 [2,610]	6,393 [2,900]
20 [500]	19¼ [489]	47 [1,194]	47 [1,194]	47¼ [1,200]	34% [866]	65 [1,652]	38% [980]	113% [2,879]	12% [320]	19¾ [500]	4¼ [108]	7,341 [3,330]	8,157 [3,700]
22 [550]	21¼ [540]	51 [1,295]	51 [1,295]	51% [1,305]	38% [974]	73% [1,863]	41¼ [1,065]	126½ [3,212]	16% [410]	31% [803]	4% [124]	8,929 [4,050]	9,921 [4,500]
24 [600]	23¼ [591]	55 [1,397]	55 [1,397]	55% [1,407]	41% [1,051]	78% [1,997]	46¼ [1,174]	136 [3,454]	16% [410]	31% [803]	4% [124]	9,700 [4,400]	11,067 [5,020]
26 [650]	25 [635]	57 [1,448]	57 [1,448]	57½ [1,461]	44¾ [1,138]	83% [2,130]	50¼ [1,276]	146¾ [3,729]	17% [453]	31% [803]	5% [149]	13,115 [5,949]	14,572 [6,610]
28 [700]	27 [686]	61 [1,549]	61 [1,549]	61½ [1,582]	48 [1,219]	88¼ [2,241]	53% [1,370]	155 [3,938]	17½ [453]	31% [803]	5% [143]	14,881 [6,750]	16,535 [7,500]
30 [750]	29 [737]	65 [1,651]	65 [1,651]	65½ [1,654]	51% [1,305]	93% [2,383]	57% [1,469]	165% [4,193]	19½ [500]	31% [803]	6% [168]	17,262 [7,830]	19,180 [8,700]
32 [800]	30¾ [781]	70 [1,778]	70 [1,778]	70% [1,794]	54% [1,375]	100% [2,550]	60 [1,525]	175% [4,455]	19% [500]	31% [803]	6 [152]	19,841 [9,000]	22,046 [10,000]
34 [850]	32¾ [832]	76 [1,930]	76 [1,930]	76% [1,946]	57% [1,450]	106% [2,715]	63% [1,615]	186 [4,725]	19% [500]	31% [803]	6 [152]	22,818 [10,350]	25,353 [11,500]
36 [900]	34½ [876]	82 [2,083]	82 [2,083]	82% [2,099]	60¼ [1,530]	110% [2,815]	68¼ [1,732]	195¼ [4,971]	20% [660]	31% [803]	8 [203]	25,992 [11,790]	28,880 [13,100]
38 [950]	36½ [927]	— [†]	— [†]	— [†]	63 [1,600]	116½ [2,960]	70% [1,800]	206¼ [5,250]	26% [660]	31% [803]	8 [203]	29,762 [13,500]	33,069 [15,000]
40 [1,000]	38½ [978]	— [†]	— [†]	— [†]	66% [1,680]	122¼ [3,105]	74 [1,880]	215% [5,470]	26% [660]	31% [803]	8 [203]	33,730 [15,300]	37,478 [17,000]
42 [1,050]	40¼ [1,022]	96 [2,439]	96 [2,439]	96% [2,455]	69% [1,770]	128¾ [3,270]	77% [1,958]	225% [5,725]	—	—	—	37,639 [17,073]	41,821 [18,970]
48 [1,200]	46 [1,168]	— [†]	— [†]	— [†]	78¾ [2,000]	145% [3,700]	88¼ [2,240]	255% [6,480]	—	—	—	52,580 [23,850]	58,422 [26,500]
54 [1,350]	51¾ [1,314]	— [†]	— [†]	— [†]	87¾ [2,230]	163% [4,150]	99 [2,515]	285% [7,260]	—	—	—	71,627 [32,490]	79,586 [36,100]
56 [1,400]	53¾ [1,365]	— [†]	— [†]	— [†]	91% [2,315]	168½ [4,280]	102% [2,600]	295% [7,510]	—	—	—	79,366 [36,000]	88,184 [40,000]
60 [1,500]	57½ [1,461]	— [†]	— [†]	— [†]	97½ [2,475]	179% [4,570]	109% [2,780]	315 [8,000]	—	—	—	97,223 [44,100]	108,025 [49,000]
60 [1,500]	57½ [1,461]	— [†]	— [†]	— [†]	95½ [2,425]	176 [4,470]	100% [2,550]	306% [7,795]	19% [500]	31½ [800]	6% [155]	29,762 [13,500]	33,069 [15,000]

[†] Upon request. Flanges up to 24 in, except 22 in, in accordance with ASME B16.5; 22 in and above 24 in in accordance with MSS-SP-44, if applicable.