

DOUBLE CHECK VALVE DC

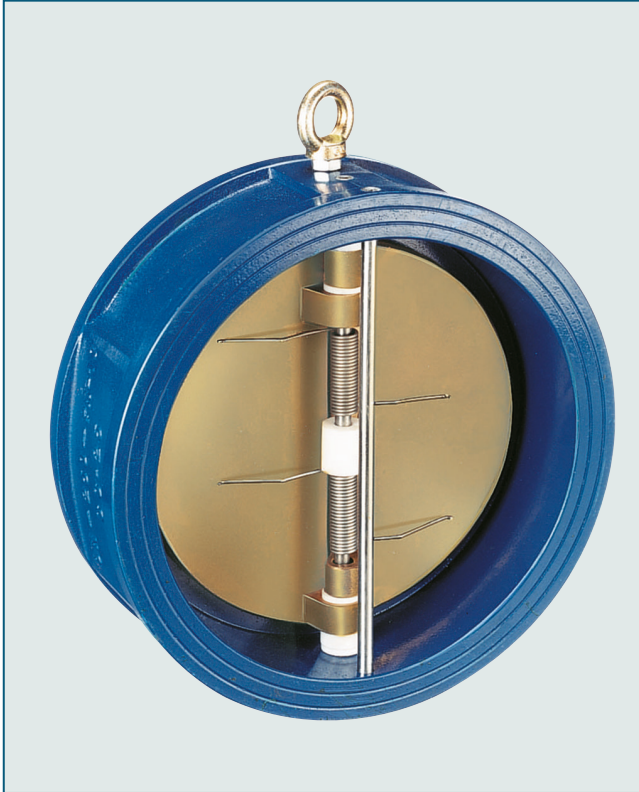

TECHNICAL DATA

Nominal diameter:	DN 50 - DN 600
Face-to-face:	EN 558-1 ISO 5752
Flange accommodation:	EN 1092 PN10/16, ASME Class 150
Flange Surface Design:	EN 1092 Form A/B ASME RF, FF
Marking:	EN 19
Operating pressure:	16 bar ≤ DN 250 10 bar ≥ DN 300
Tightness check:	EN 12266 (Leakage Rate A) ISO 5208, Category 3
Temperature range:	0°C to +130°C (depending on pressure, medium and temperature)

Standard construction:

TYP	DC 1	DC 2	DC 3	DC 4	DC 5
Body	EN-JS 1030	EN-JS 1030	1.4408	Alu-Bronze C954	EN-JS 1030
Disc	Alu-Bronze C954	1.4408	1.4408	Alu-Bronze C954	EN-JS 1030
Shafts	1.4301	1.4301	1.4404	Alu-Bronze C954	1.4301
Springs	1.4571	1.4571	1.4401	2.4816	1.4571
Bearing operating	NBR	EPDM	EPDM	NBR	EPDM
Lager	PTFE	PTFE	PTFE	PTFE	PTFE

FEATURES

- Maintenance-free wafer double check valve
- Can be disassembled, material-specific recycling possible

PRESSURE LOSS DIAGRAM DN 50 - DN 300

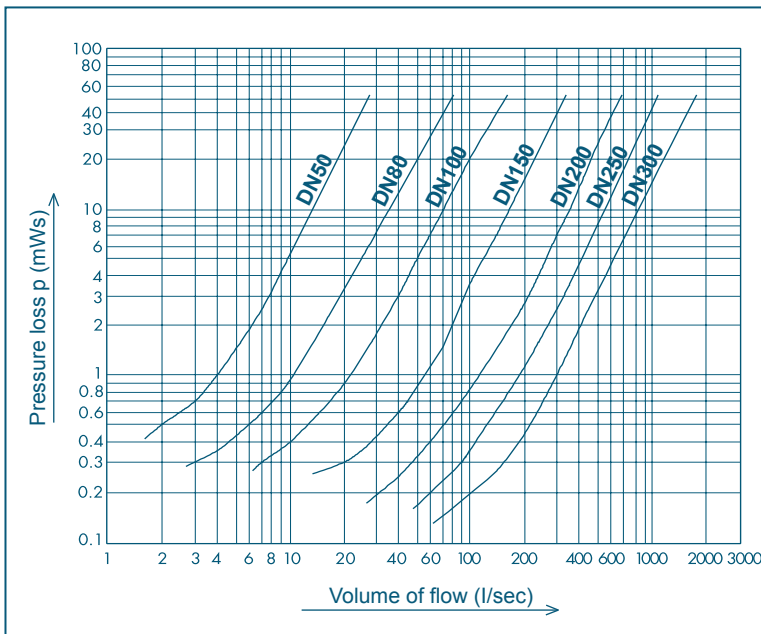

The values given in the diagram are valid for water at 20°C. They result of measurements at valves which are mounted in a horizontal conduction. For the ascertainment of pressure losses for other media, the water flow amount has to be calculated with the following formular:

$$W_{ap} = \sqrt{\frac{\gamma_B}{1000}} \times Q_B$$

W_{ap} = equivalent water flow in m³/h

γ_B = flow amount of the media in its operating conditions kg/m³

Q_B = volume of flow in operating condition (m³/h)

DOUBLE CHECK VALVE DC

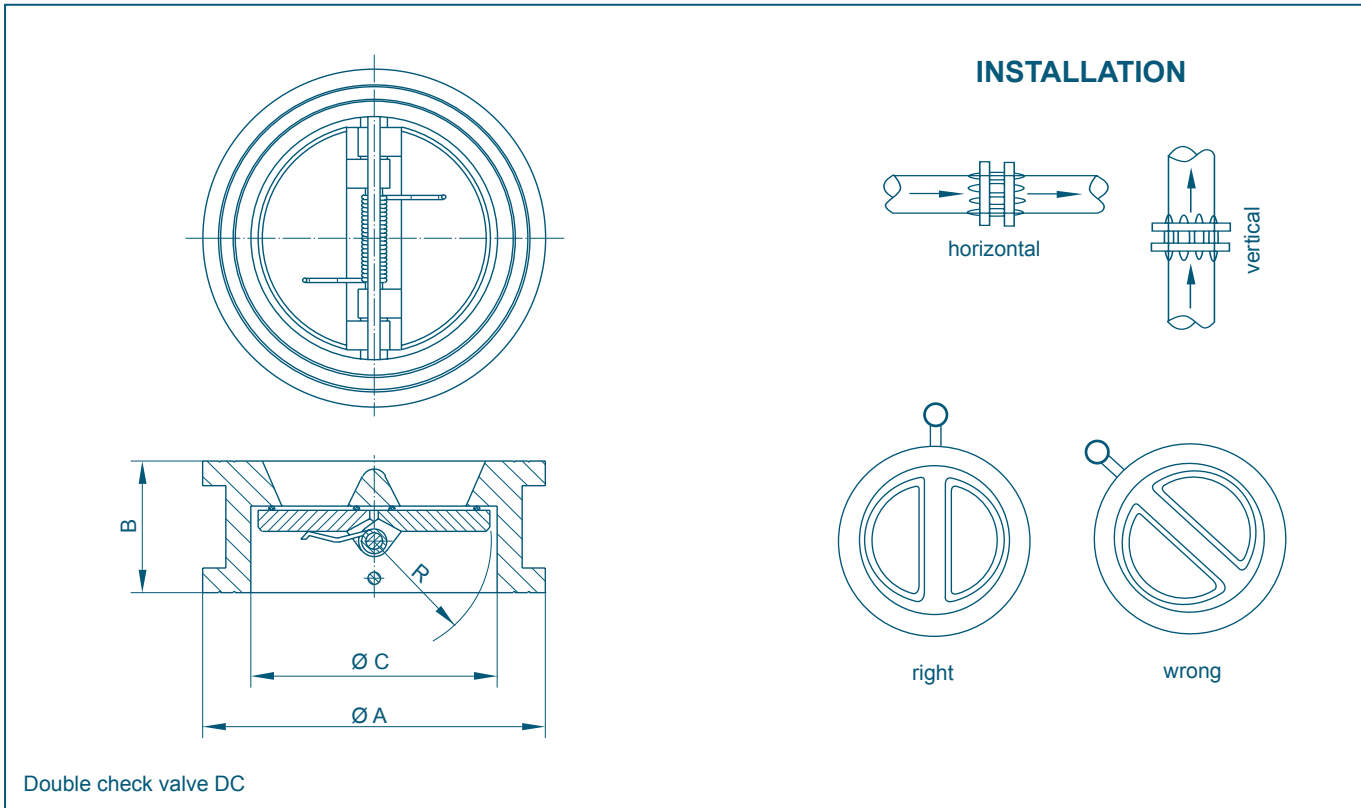

DN [mm]	Size [in]	Dimensions [mm]				min. opening pressure [mbar]	K _V [m ³ /h]	Weight [kg]
		A	B	C	R			
50	2	107	43	65	29	20	63	1,5
65	2½	127	46	80	36	20	109	2,4
80	3	142	64	94	43	20	172	3,6
100	4	162	64	117	53	20	289	5,7
125	5	192	70	145	66	20	476	7,3
150	6	218	76	170	79	20	750	9,0
200	8	273	89	224	104	20	1550	17,0
250	10	328	114	265	127	20	2880	26,0
300	12	378	114	310	148	20	4100	42,0
350	14	438	127	360	172	30	5274	55,0
400	16	489	140	410	197	30	8250	75,0
450	18	539	152	450	218	30	10550	101,0
500	20	594	152	505	241	30	14500	111,0
600	24	695	178	624	295	30	24000	172,0

Installing the check valve on top of a pump please ensure that neither the valve is mounted directly on the pump flange or the following bend or a smoothing section of less than 5 x DN is observed.

For tight sealing of the DC a back pressure of not less than 1 bar is required.

Subject to change without notice