

12	Scale Plate	Aluminium	指示板	A1050	1
11	Scale Plate	Aluminium	指示板	A1050	1
10	Spindle	Stainless Steel	スピンドル	SUS304	1
9	Flap Spring	Stainless Steel	フラップばね	SUS304	1
8	Flap	Stainless Steel	フラップ	SUS304	1
7	Spring Washer	Carbon Steel	ばね座金	SWRH	4
6	Nut	Carbon Steel	六角ナット	S25C or S45C	4
5	Bolt	Carbon Steel	六角ボルト	SCM435	4
4	Gasket	Non-Asbestos	ガスケット	Non-Asbestos	2
3	Glass	Tempered Glasses	ガラス	強化ガラス	2
2	Cover	Ductile Cast Iron	ふた	FCD450	2
1	Body	Ductile Cast Iron	本体	FCD450	1
No.	Name of Parts	Material	部品名	材質	Q. TY

(mm)

Size	L	A	B	W	Flange JIS 10KFF					Weight (kg)
					d	D	C	T	n-h	
15A	130	79	55	35	15	95	70	12	4-15	2.2
20A	130	79	55	35	20	100	75	14	4-15	2.6
25A	150	99.5	70	44	25	125	90	14	4-19	4.1

Specification	
Fluid	
Press.	MPa
Temp.	℃

TYPE SF-1F SIGHT GLASS  
フラップ式サイトグラス

Approval	H. Iwamoto
Check	M. Yoshida
Drawing	H. Okumua
Drawing No.	Y-1062-6505-2A
Date	11 SEP. 2012



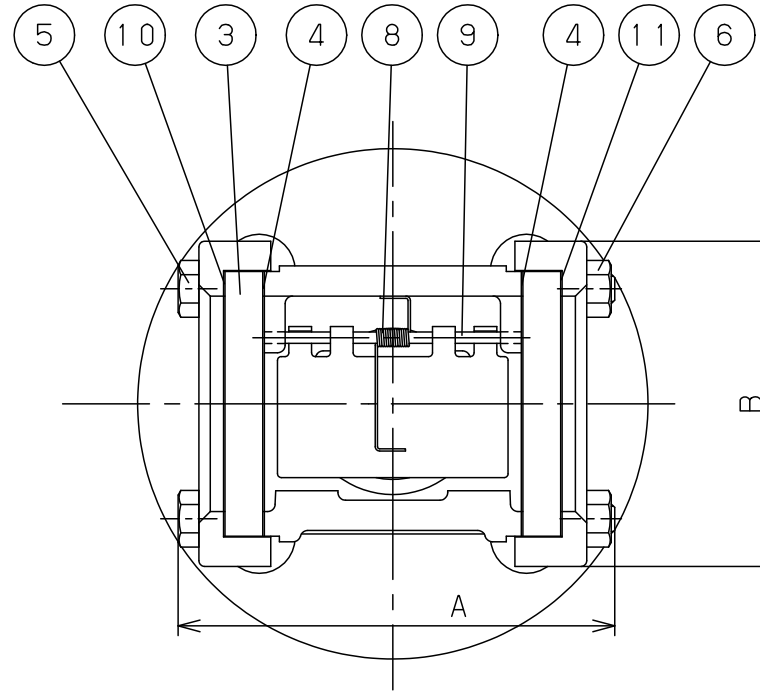
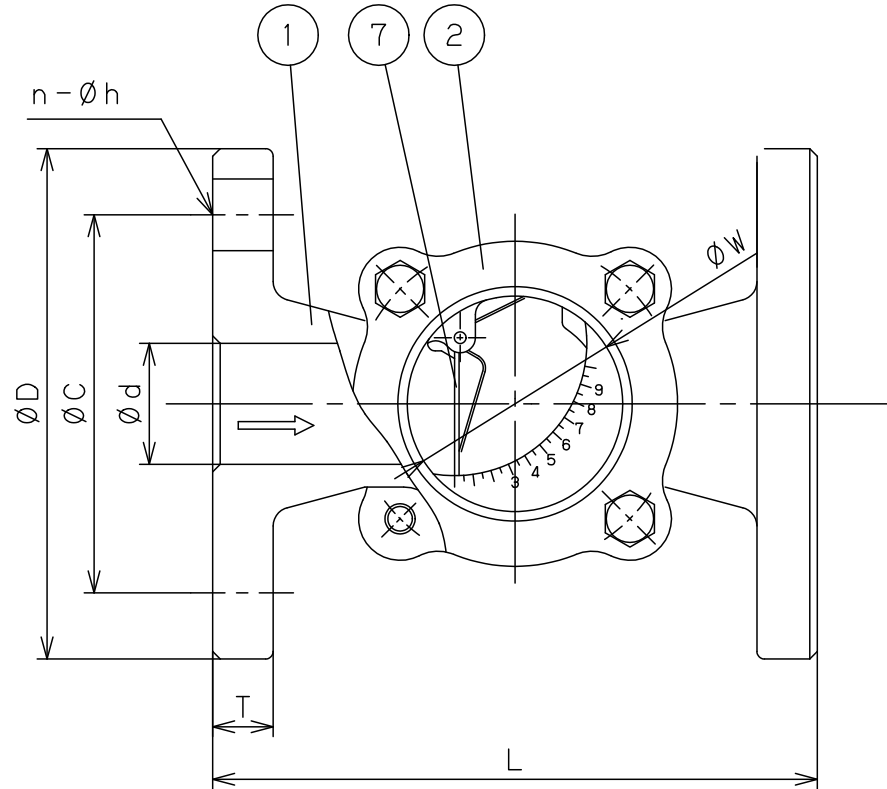
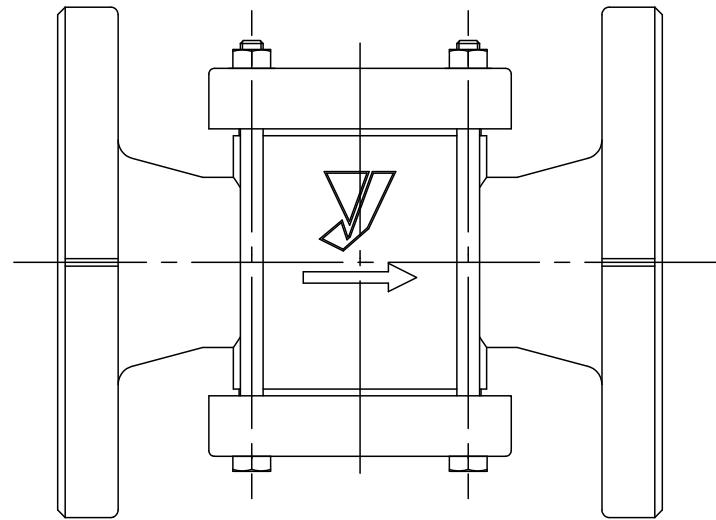

11	Scale Plate	Aluminium	指示板	A1050P	1
10	Scale Plate	Aluminium	指示板	A1050P	1
9	Spindle	Stainless Steel	スピンドル	SUS304	1
8	Flapper Spring	Stainless Steel	フラッパーばね	SUS304	1
7	Flapper	Stainless Steel	フラッパー	SUS304	1
6	Nut	Carbon Steel	六角ナット	S45C	4
5	Bolt	Carbon Steel	六角ボルト	SCM435	4
4	Gasket	Non-Asbestos	ガスケット	Non-Asbestos	2
3	Glass	Tempered Glasses	ガラス	強化ガラス	2
2	Cover	Ductile Cast Iron	ふた	FCD450	2
1	Body	Ductile Cast Iron	本体	FCD450	1
No.	Name of Parts	Material	部品名	材質	Q.TY

Size	L	A	B	W	Flange JIS 10KFF					Weight (kg)
					d	D	C	T	n-h	
32A	160	115.5	86	57	32	135	100	16	4-19	5.9
40A	170	115.5	86	57	40	140	105	16	4-19	6.2
50A	200	147	114	73	50	155	120	16	4-19	9.5

Specification	
Fluid	
Press.	MPa
Temp.	°C

## TYPE SF-1F SIGHT GLASS フラップ式サイトグラス

Approval	M. Kume
Check	M. Kume
Drawing	Y. Aoyama
Drawing No.	Y-1062-6505
Date	2 JUL.2010

**Joshitake**  
INC.