

Diaphragm	EPDM	EPDM
Disc	EPDM	EPDM
Valve Seat	Bronze	CAC406
Body	Bronze	CAC406
Name of Parts	Material	

(mm)

Size	L	H1	H	A	Weight (kg)
25A	160	41	170	101	5.1
32A	200	57	224	116	7.5
40A	200	57	224	116	7.7
50A	220	61	239.5	137	10.9

**TYPE GD-27
PRESSURE REDUCING VALVE**

Approval	M. KUME
Check	M. KUME
Drawing	H. TANGE
Drawing No.	Y-558-9905
Date	5 JAN.2005



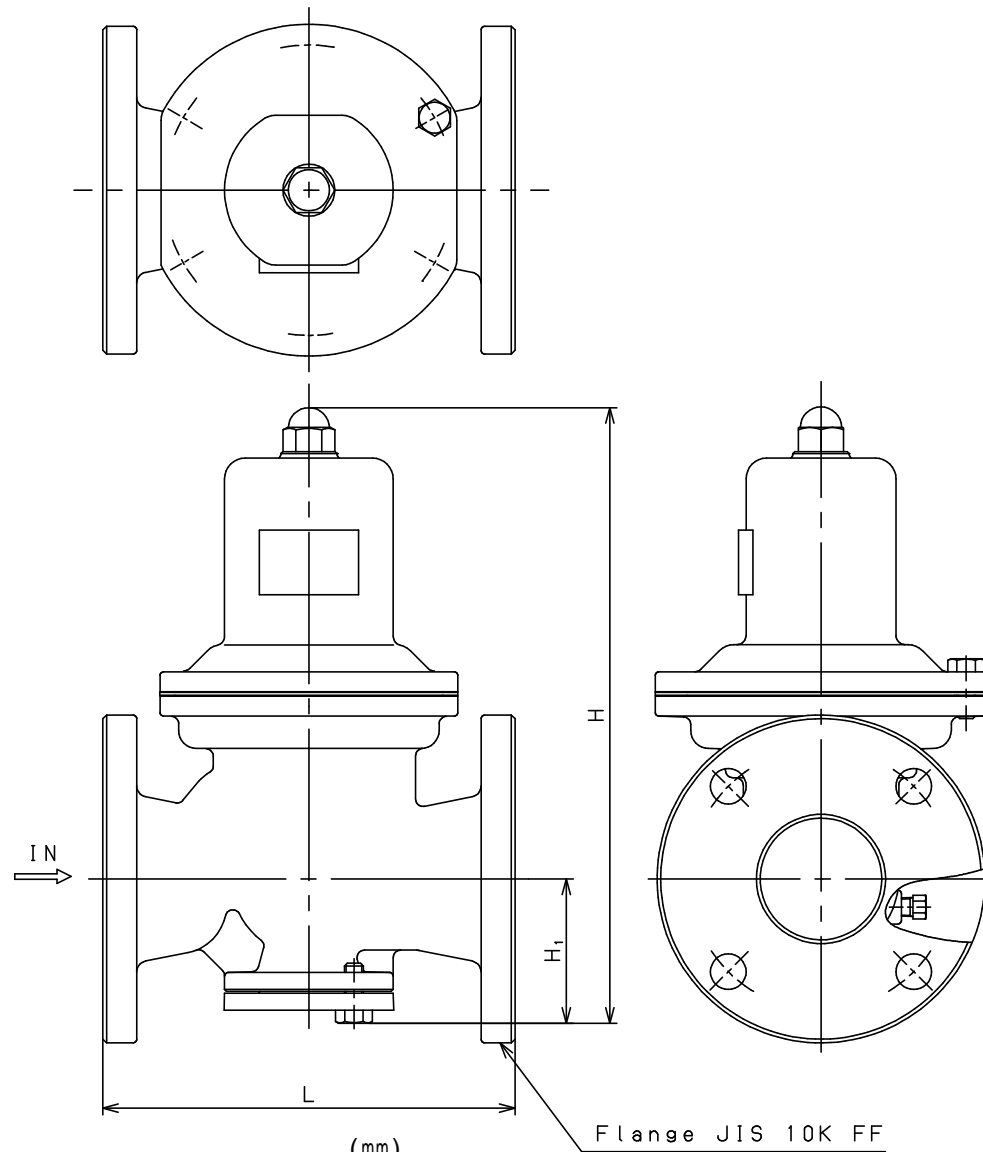

(mm)

Size	L	H1	H	Weight (kg)
65A	220	77	329	20.0
80A	230	82	345	22.0
100A	270	94	412	33.0

Diaphragm	EPDM	EPDM
Disc	EPDM	EPDM
Valve Seat	Bronze	CAC406
Body	Bronze	CAC406
Name of Parts	Material	

**TYPE GD-27
PRESSURE REDUCING VALVE**

Approval	M. KUME
Check	M. KUME
Drawing	H. TANGE
Drawing No.	Y-558-9905
Date	6 JAN.2005

