

9	Gasket	PTFE	ガスケット	PTFE	2
8	Stud Bolt	Stainless Steel	スタットボルト	SUS304	8
7	Stud Bolt	Stainless Steel	スタットボルト	SUS304	2
5	Nut	Stainless Steel	六角ナット	SUS304	12
4	Gasket	Non-Asbestos	ガスケット	Non-Asbestos	2
3	Glass	Tempered Glasses	ガラス	強化ガラス	2
2	Cover	Cast Stainless Steel	ふた	SCS13	2
1	Body	Cast Stainless Steel	本体	SCS13	1
	Name of Parts	Material	部品名	材質	Q.TY

Size	L	A	B	W	Flange JIS 10K FF (mm)					Weight (kg)
					d	D	C	T	n-h	
100A	277	244	207	130	100	210	175	18	8-19	29.2

Specification	
Fluid	
Press.	MPa
Temp.	

TYPE 150L-13F SIGHT GLASS
サイトグラス

Approval	M. Kume
Check	M. Kume
Drawing	Y. Aoysma
Drawing No.	Y-0473-3405
Date	26 JUL. 2007



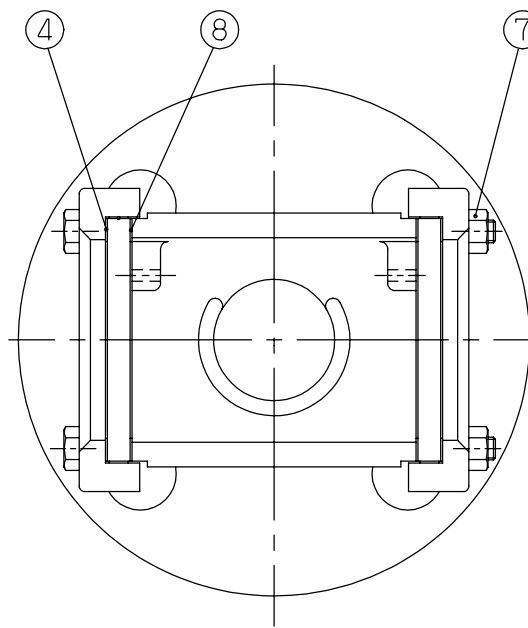
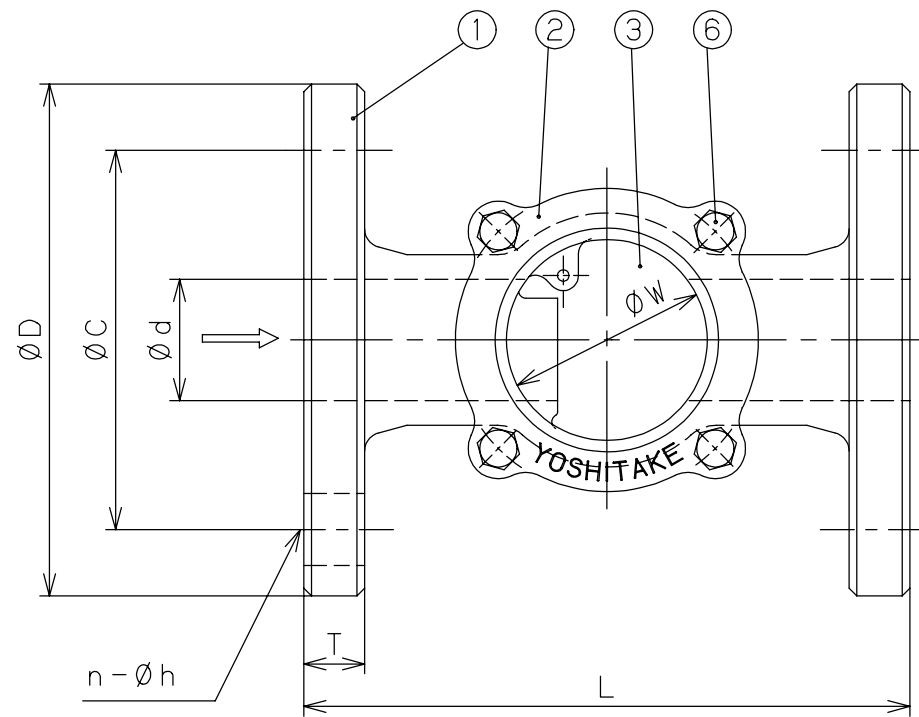
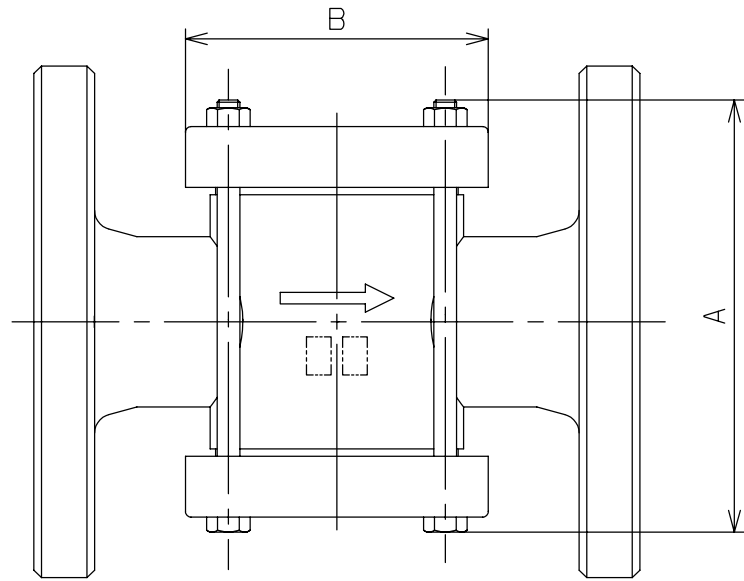

8	Gasket	PTFE	ガスケット	PTFE	2
7	Nut	Stainless Steel	六角ナット	SUS304	4
6	Bolt	Stainless Steel	六角ボルト	SUS304	4
4	Gasket	Non-Asbestos	ガスケット	Non-Asbestos	2
3	Glass	Tempered Glasses	ガラス	強化ガラス	2
2	Cover	Cast Stainless Steel	ふた	SCS13	2
1	Body	Cast Stainless Steel	本体	SCS13	1
	Name of Parts	Material	部品名	材質	Q.TY

Size	L	A	B	W	Flange JIS 10KFF (mm)					Weight (kg)
					d	D	C	T	n-h	
15A	130	73.5	51	35	15	95	70	12	4-15	2.1
20A	130	73.5	51	35	20	100	75	14	4-15	2.5
25A	150	89.0	67	44	25	125	90	14	4-19	4.1
32A	160	114.0	80	53	32	135	100	16	4-19	5.4
40A	170	115.5	86	57	40	140	105	16	4-19	5.6
50A	200	147.0	114	73	50	155	120	16	4-19	9.7
65A	235	178.0	140	97	65	175	140	18	4-19	16.0
80A	235	188.0	140	97	73	185	150	18	8-19	16.5

Specification	
Fluid	
Press.	MPa
Temp.	

TYPE 150L-13F SIGHT GLASS
サイトグラス

Approval	M. Kume
Check	M. Kume
Drawing	Y. Aoyama
Drawing No.	Y-0473-3405
Date	25 JUL. 2007

