

SPECIFICATIONS:

- Split Body 2 piece type, or 3 piece type, to allow inspection and maintenance on all internal parts.
- Available in Stainless Steel, Cast Iron or Carbon Steel Body construction.
- Anti Blow-out Stem.
- Fire-Safe design or Non-Fire-Safe design
- F-F dimensions: ANSI B16.10. Yone Std. or Din 3357 (Ik)
- End flanges: ANSI B16.5. JIS B2210 or Din 2501
- Operator: Level Operator, Gear Operator

MATERIAL:

- ASTM A351 GR. CF8
- ASTM A351 GR. CF8M
- ASTM A216 GR. WCB
- Special Alloy upon request
- ASTM A126 CL.B

TEST: ANSI B16.34

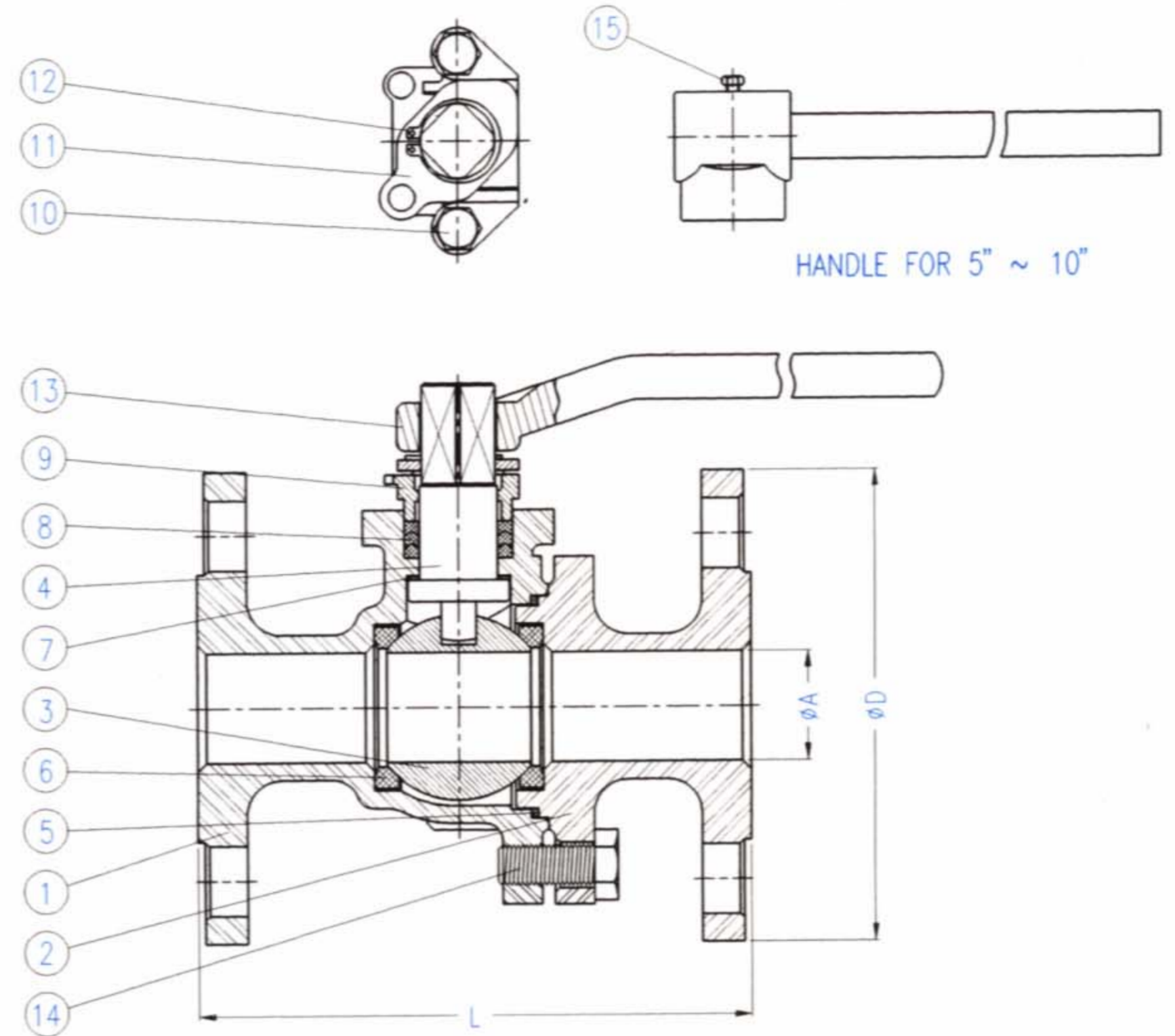
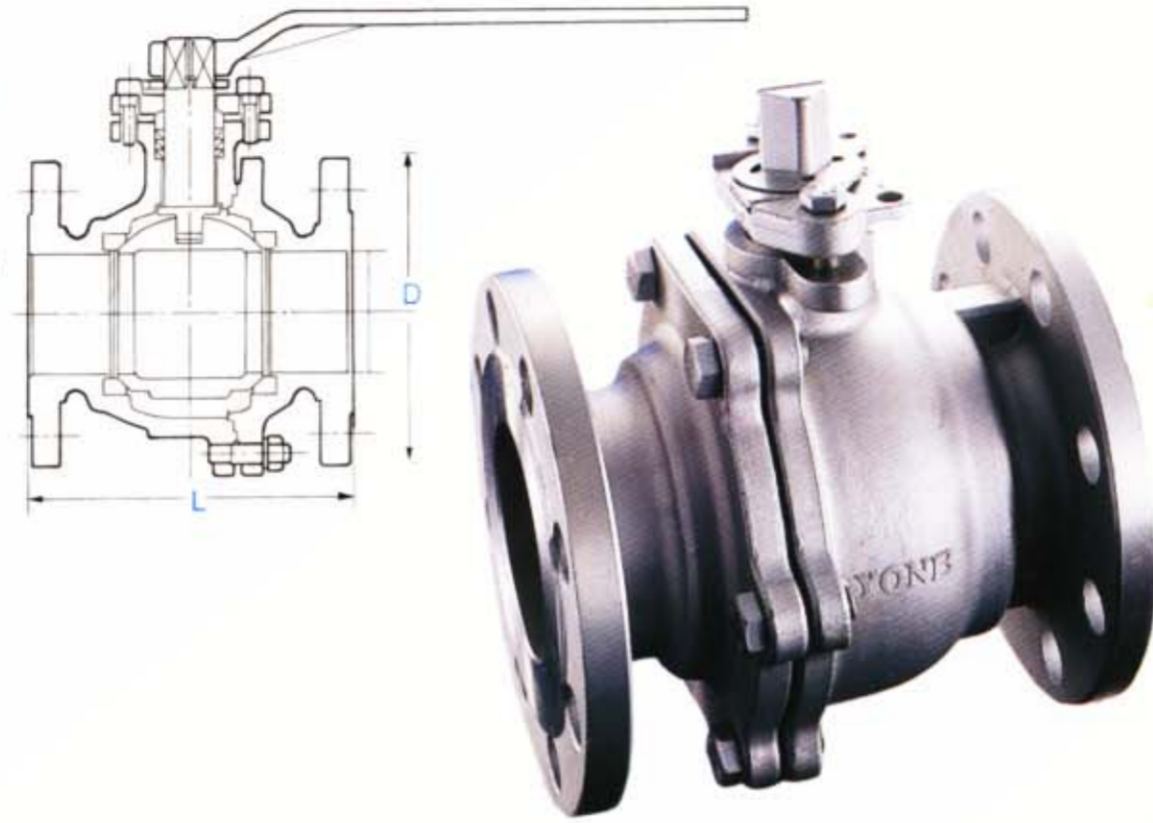

Design		Ball Valve, Floating Ball Design, RF-flanged																	
Class	JIS 10K			JIS 20K			ANSI 150LB			ANSI 300LB			PN10、16、25、40						
	Size	Bore	L	D	Bore	L	D	Bore	L	D	Bore	L	D	Bore	L	D	D	D	D
1/2"	15	15	110	95	15	140	95	15	108	89	15	140	95	15	115	95	95	95	95
3/4"	20	20	120	100	20	152	100	20	117	98	20	152	117	20	120	105	105	105	105
1"	25	25	130	125	25	165	125	25	127	108	25	165	124	25	125	115	115	115	115
1 1/4"	32	32	140	135	32	178	135	32	140	117	32	178	133	32	130	140	140	140	140
1 1/2"	40	40	165	140	40	190	140	40	165	127	40	190	156	40	140	150	150	150	150
2"	50	50	180	155	50	216	155	50	178	152	50	216	165	50	150	165	165	165	165
2 1/2"	65	65	190	175	65	241	175	65	190	178	65	241	190	65	170	185	185	185	185
3"	80	80	200	185	80	283	200	80	203	190	80	283	210	80	180	200	200	200	200
4"	100	100	230	210	100	305	225	100	229	229	100	305	254	100	190	220	220	235	235
5"	125	125	300	250	125	381	270	125	356	254	125	381	279	125	325	250	250	270	270
6"	150	150	340	280	150	403	305	150	394	279	150	403	318	150	350	285	285	300	300
8"	200	200	450	330	200	502	350	200	457	343	200	502	381	200	400	340	340	360	375
10"	250	250	533	400	250	568	430	250	533	406	250	568	444	250	450	395	405	425	450
12"	300	300	610	445	300	648	480	300	610	483	300	648	521						
14"	350	350	686	490	350	762	540	350	686	533	350	762	584						
16"	400	400	762	560	400	838	605	400	762	597	400	838	648						
18"	450	450	864	620	450	914	675	450	864	635	450	914	711						

NO.	PART NAME	MATERIAL		
		STAINLESS STEEL	STAINLESS STEEL	CARBON STEEL
1	BODY	316SS (SCS 14)	304SS (SCS 13)	ASTM A216 Gr. WCB
2	CAP	316SS (SCS 14)	304SS (SCS 13)	ASTM A216 Gr. WCB
3	BALL	316SS (SCS 14)	304SS (SCS 13)	304SS
4	STEM	316SS	304SS	304SS
5	GASKET	PTFE	PTFE	PTFE
6	SEAT	PTFE	PTFE	PTFE
7	THRU WASHER	PTFE	PTFE	PTFE
8	PACKING	PTFE	PTFE	PTFE
9	GLAND	304SS (SCS 13)	304SS (SCS 13)	304SS (SCS 13)
10	GLAND BOLT	ASTM A193 Gr. B8	ASTM A193 Gr. B8	ASTM A193 Gr. B7
11	STOPPER	304SS	304SS	304SS
12	SNAP RING	304SS	304SS	CARBON STEEL
13	HANDLE	FCD 45	FCD 45	FCD 45
14	CAP BOLT	ASTM A193 Gr. B8	ASTM A193 Gr. B8	ASTM A193 Gr. B7
15	HANDLE BOLT	ASTM A193 Gr. B7	ASTM A193 Gr. B7	ASTM A193 Gr. B7