

Gate Valve

Indicator Post - Underground Type

Fig.G388

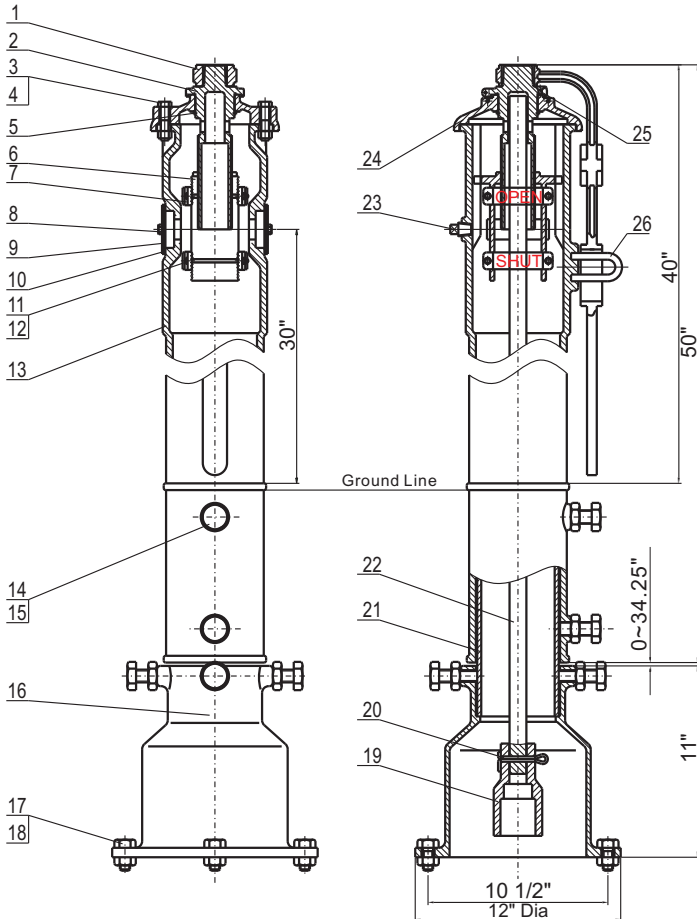
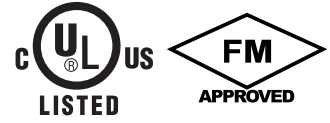

Materials List

DET	QTY.	Description	Material
1	1	Locking Wrench	ASTM A126B
2	1	Operating Nut	ASTM B62
3	2	Hex Nut Screw	ASTM A105
4	2	Hex Nut	ASTM A105
5	1	Snap Ring	AISI 066
6	1	Target Carrier Nut	ASTM B62
7	4	Target	ASTM B108
8	4	Hex Cap Screw	ASTM A105
9	2	Window Glass	LEXAN-UM
10	2	Window Glass Gasket	PTFE
11	4	Hex Cap Screw	ASTM A105
12	4	Hex Nut	ASTM A105
13	1	Body	ASTM A536
14	6	Hex Cap Screw	ASTM A105
15	6	Hex Nut	ASTM A105
16	1	Base Flange	ASTM A126B
17	4	Hex Cap Screw	ASTM A105
18	4	Hex Nut	ASTM A105
19	1	Crane Coupling	ASTM A536
20	1	Cotter Pin	AISI 304
21	1	Stand Pipe	ASTM A53
22	1	Stem	AISI 1045
23	1	Plug	AISI 304
24	1	Cover	ASTM A126B
25	1	Cross Recessed Countersunk Head Screw	AISI 304
26	1	Locking Nose	ASTM 307 B

Field Adjustment:

1. Remove the top section from the top of the Indicator Post assembly.
2. Cut the required length off the bottom of the Standpipe for the Ground Line to match up with Standpipe Ground Line mark.
3. Set the "OPEN" and "SHUT" targets for the appropriate valve size.
4. Reattach the Top Section to the top of the Indicator Post assembly.
5. Design and dimensions are subject to change without notice