

Dry Barrel Fire Hydrant

Fig.1510

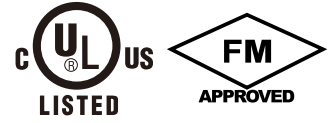

Technical Specification

| | |
|------------------------|---|
| Design Standard | FM 1510/UL 246/AWWA C502 |
| Nozzle Thread Standard | NFPA 1963 |
| Hose Nozzle | 2-1/2"-Two |
| Pumper Nozzle | 4" or 4-1/2"-One |
| Mechanical Joint | Size: 6" ANSI/AWWA C153/A21.53 |
| Flange End | Size: 6" ANSI Class 125 / BS EN1092-2 PN16 |
| Working Pressure | 250PSI |

| Part Name | Material |
|---------------------------|-------------------|
| Operating Nut | C84400 |
| Lock Nut | A351 CF8 |
| Antifriction Mat | C63000 |
| Cover | A536 65-45-12 |
| Top Shaft | AISI 420 |
| Fire Engine Nozzle Cap | A536 65-45-12 |
| Fire Engine Nozzle Gasket | EPDM |
| Fire Engine Nozzle | C84400 |
| Chain | Carbon Steel + Zn |
| O-Ring | EPDM |
| Coupling | AISI 420 |
| Safety Flange | A126B |
| Under Shaft | SS420 |
| MJ Elbow Body | A536 65-45-12 |
| Hexagon Head Bolts | AISI 304 |
| Hexagonal Nut | AISI 304 |
| Pin | AISI 304 |
| Cotter Pin | AISI 304 |
| Hexagon Head Bolts | AISI 304 |
| Hexagonal Nut | AISI 304 |
| O-Ring | EPDM |
| Pin | AISI 304 |
| Cotter Pin | AISI 304 |
| Hose Nozzle Cap | A536 65-45-12 |
| Hose Nozzle Gasket | EPDM |
| Hose Nozzle | C84400 |
| Drain Sealing Strip | PE |
| Countersunk Head Screw | AISI 304 |
| Disc | C84400 |
| Seat | C84400 |
| Drainage Ring | C84400 |
| Nut | A536 65-45-12 |
| Nut Washer | AISI 304 |
| Hexagon Head Bolts | AISI 304 |
| Washer | AISI 304 |
| Hexagonal Nut | AISI 304 |

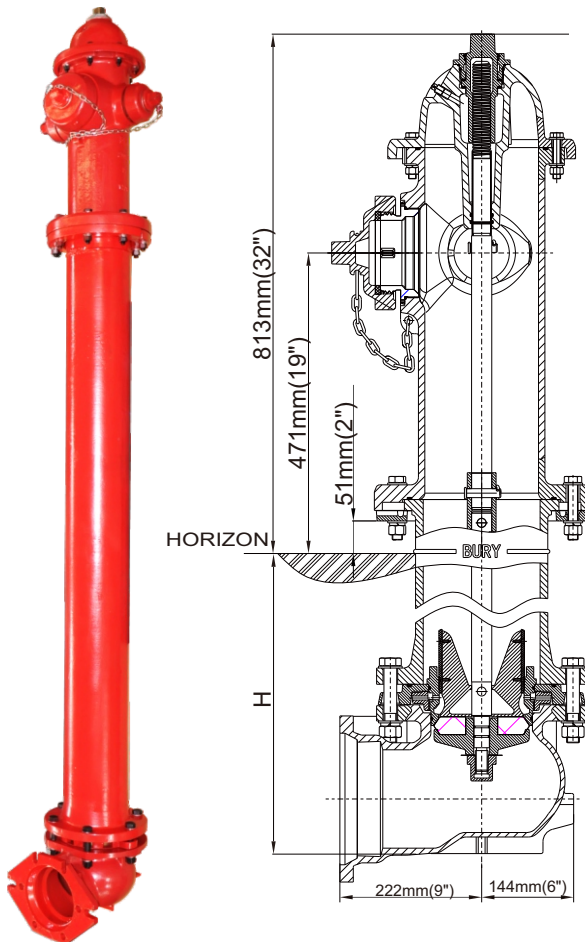

Dimension

| | | | | | | | | | |
|----------|-----------|---------------|---------------|---------------|---------------|---------------|---------------|---------------|---------------|
| H | 912mm(3') | 1065mm(3'-6") | 1217mm(4'-0") | 1370mm(4'-6") | 1522mm(5'-0") | 1674mm(5'-6") | 1827mm(6'-0") | 1979mm(6'-6") | 2132mm(7'-0") |
|----------|-----------|---------------|---------------|---------------|---------------|---------------|---------------|---------------|---------------|