

Fig. 5101(PN16/Class 125)  
5102(Class 250)



**Valve Standard :**

Comply with EN 12334(BS 5153) & MSS SP-71

**Pressure Temperature Ratings**

Working pressure	16bar/125Lb/250Lb
Testing Pressure	Shell:24bar/51.7
	Seal:17.6bar/34.5
Working Temperature	-10°C to 120°C
Suitable Media	Water,Oil&Gas

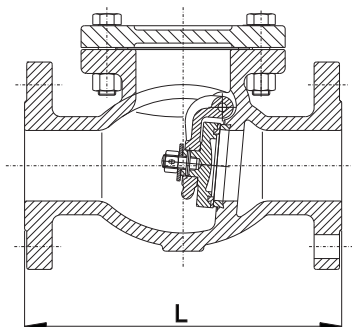

**Material Specification**

Part	Material	ASTM Spec.
Body	Cast Iron	A126 Class B
Disc	Cast Iron	A126 Class B
Seat Ring	Bronze	B62 C83600
Disc Ring	Bronze	B62 C83600

**Dimensions**

DN	mm	50	65	80	100	125	150	200	250	300	350	400	450	500	600
	inch	2	2-1/2	3	4	5	6	8	10	12	14	16	18	20	24
L(PN16/Class125)		203	216	241	292	330	356	495	622	699	787	914	914	1016	1219
L(Class250)		267	292	318	356	400	444	533	622	711	-	-	-	-	-