

**BDK™**  
Industrial Valves

Excellent  
Engineering  
Solutions

**WEIR**



**Plug Valves**  
Sleeved & Lined

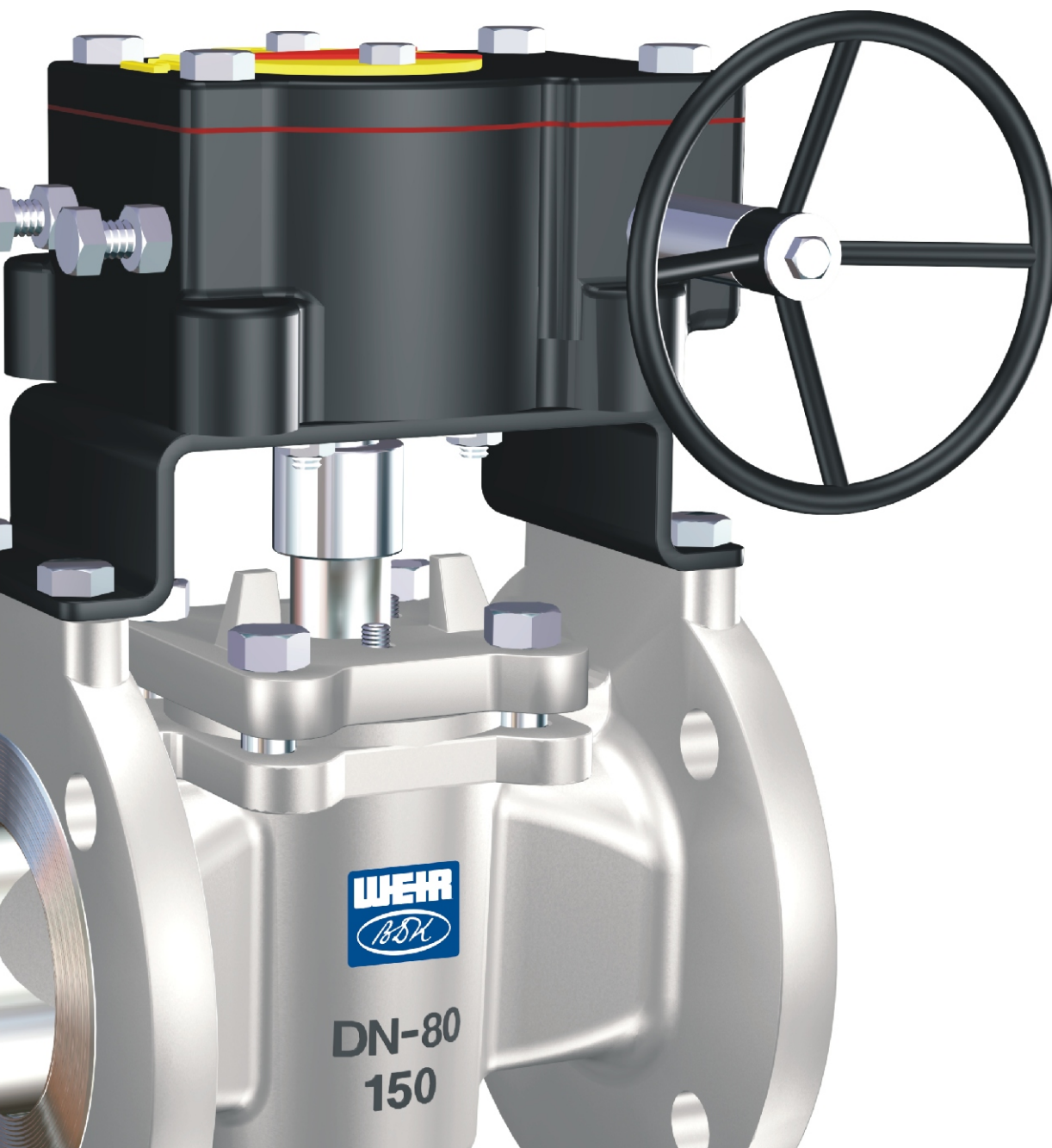

# Sleeved Plug Valves

## Valve parts

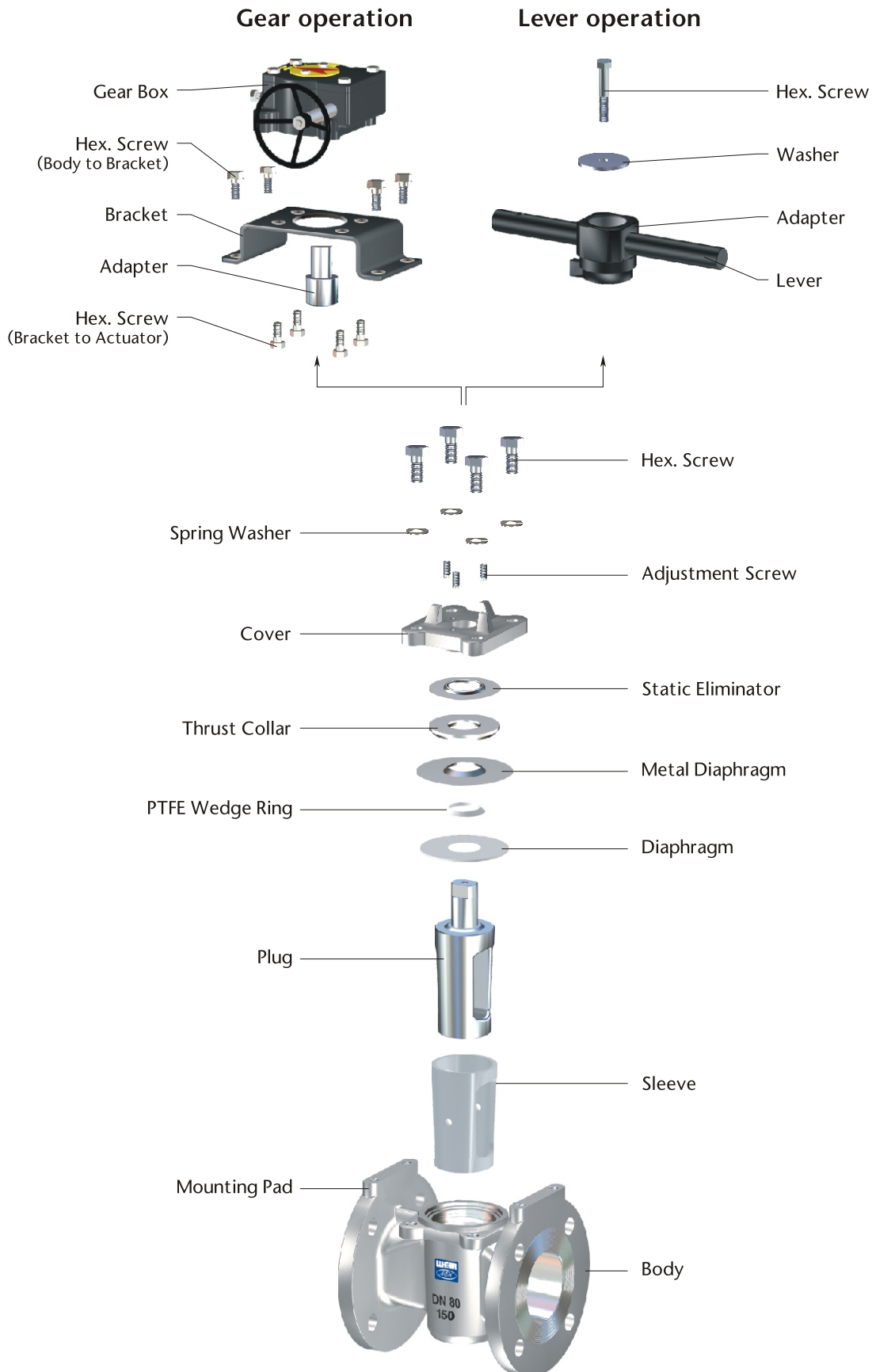

# Sleeved Plug Valves

## Class 150 & 300

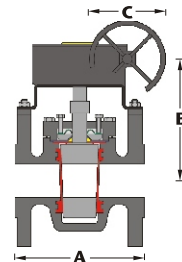
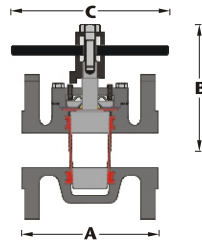

### Applications (Standard Plug valves)

- Chemical Process Plants
- Fertilizer Plants
- Dyes and Pigments
- Pesticides
- Caustic Chlorine Plants
- Hazardous Fluids
- Acids and Alkalies

### Applications (Caged Plug valves)

- Phosphoric Acid Slurry
- Titanium Dioxide Slurry
- Suspended Solid Slurries
- Uranium Ore Slurries
- Caustic Soda & Lime Slurry
- Heavy Black Liquor
- Fly Ash

### Test pressure in bar (psi)

Pressure rating <sup>2)</sup>	Class 150	Class 300	PN10	PN16
Hyd. Shell	30 (435)	76 (1102)	15 (218)	24.0 (348)
Seat	22 (319)	56 (812)	11 (160)	17.6 (255)
Air Seat	← 7.0 (102) →			

Design STD : API 599, BS 5353 & API 6D

Testing STD : API 598 & EN 12266-1

### Dimensions are in mm (inch)

Size mm (inch)	A			B	C	Port area mm <sup>2</sup> (inch <sup>2</sup> )	% Port Open	Wt 1)		
	Class 150	Class 300	DIN					Class 150	Class 300	DIN
15 (1/2)	108 (4.3)	140 (5.5)	130 (5.1)	95 (3.7)	225 (8.9)	120 (0.19)	92	2.0 (4.5)	3.5 (8)	2.6 (6)
20 (3/4)	117 (4.6)	152 (6.0)	150 (5.9)	100 (3.9)	225 (8.9)	240 (0.37)	86	2.5 (5.5)	5.0 (11)	3.5 (8)
25 (1)	140 (5.5)	165 (6.5)	160 (6.3)	110 (4.3)	225 (8.9)	390 (0.60)	80	4.5 (10)	6.5 (14)	5.7 (13)
32 (1 1/4)	165 (6.5)	178 (7.0)	180 (7.1)	110 (4.3)	325 (12.8)	545 (0.84)	68	6.0 (13)	9.0 (20)	8.0 (18)
40 (1 1/2)	165 (6.5)	190 (7.5)	200 (7.9)	120 (4.7)	325 (12.8)	750 (1.16)	66	7.5 (17)	11 (24)	9.6 (21)
50 (2)	178 (7.0)	216 (8.5)	230 (9.1)	145 (5.7)	450 (17.7)	1450 (2.25)	74	12 (27)	16 (35)	15 (33)
65 (2 1/2)	190 (7.5)	241 (9.5)	290 (11.4)	141 (5.6)	450 (17.7)	2080 (3.22)	66	15 (33)	19 (42)	22 (49)
80 (3)	203 (8.0)	283 (11.1)	310 (12.2)	160 (6.3)	450 (17.7)	2540 (3.94)	53	18 (40)	22 (49)	24 (53)
100 (4)	229 (9.0)	305 (12.0)	350 (13.8)	195 (7.7)	750 (29.5)	4470 (6.93)	57	30 (66)	44 (97)	38 (84)
125 (5)	254 (10.0)	381 (15.0)	400 (15.7)	236 (9.3)	450 (17.7)	7305 (11.32)	58	52 (115)	78 (172)	78 (172)
150 (6)	267 (10.5)	403 (15.9)	480 (18.9)	250 (9.8)	450 (17.7)	10010 (15.52)	55	60 (132)	91 (212)	90 (198)
200 (8)	292 (11.5)	419 (16.5)	600 (23.6)	280 (11.0)	500 (19.7)	15800 (24.50)	49	96 (212)	148 (326)	166 (366)
250 (10)	330 (13.0)	457 (18.0)	730 (28.7)	340 (13.4)	500 (19.7)	23820 (36.92)	47	142 (313)	210 (463)	270 (595)
300 (12)	356 (14.0)	502 (19.8)	850 (33.5)	390 (15.4)	500 (19.7)	31220 (48.40)	43	195 (430)	295 (650)	395 (870)
350 (14)	381/686 (15.0/27.0)	-	-	450 (17.7)	500 (19.7)	38180 (59.18)	43	270/300 (595/661)	-	-
400 (16)	762 (30.0)	-	-	595 (23.4)	500 (19.7)	74458 (115.41)	61	560 (1235)	-	-
450 (18)	864 (34.0)	-	-	650 (25.6)	500 (19.7)	97938 (151.80)	65	950 (2094)	-	-

### Materials

Body & Cover <sup>3)</sup>	Ductile Iron ASTM A395/ Steel ASTM A216 Gr. WCB/ ASTM A351 Gr. CF8 / CF8M / CN7M
Plug	Steel ASTM A217 Gr. CA15 / ASTM A351 Gr. CF8 / CF8M / CN7M
Sleeve / Diaphragm	PTFE / CFT / GFT
Wedge Ring	PTFE / CFT / GFT / Grafoil <sup>5)</sup>
Metal Diaphragm / Static Eliminator	ASTM A240 Type 304
Thrust Collar	ASTM A351 Gr. CF8
Adjusting Screws	ASTM A276 Type 304
Fasteners	SS 304
Adapter / Lever	Steel - Powder coated
Gear Unit	Housing in Cast Iron, Gear in S. G. Iron and Worm in EN8
Bearing <sup>4)</sup>	PTFE
Body Gasket <sup>5)</sup>	Grafoil
Surface Protection for Ductile Iron and Cast Carbon Steel Valves	Prime Coat : Chlorine free with modified alkyd resin unobjectionable in physiological and toxicological respects. Additional External Coating : Synthetic Enamel.

1) Nett in kg (lbs) approx. (without obligation) 2) Pressure rating : PN10 & PN16 for DIN valves. 3) DI material for class 150 & also for Non Fire-safe design only. 4) For Caged valves only. 5) For Fire-safe valves only. • Gear actuators mandatory for sizes 125mm (5") & above. • Valves can be supplied to suit ASME B16.5 flanges. Other drilling on request if possible. • Face to face dimensions (A) as per ASME B16.10 short for sizes 15mm (1/2") to 300mm (12") & regular for sizes 350mm (14") & above (EN 558 Series-3 for class 150 sizes up to 350mm (14"), Series-12 for size 400mm (16") & 450mm (18"), Series-4 for class 300), EN 558 Series-1 for DIN valves. • Please specify working pressure, temperature & service conditions. • Valves can be supplied with Locking, Extended Stem / Electrical / Pneumatic Actuators, & accessories like Limit Switch, Solenoid Valve, Air Filter Regulator, Positioner etc. • Other materials not mentioned above available on request.

# Sleeved Plug Valves

Class 150, 300 & 600

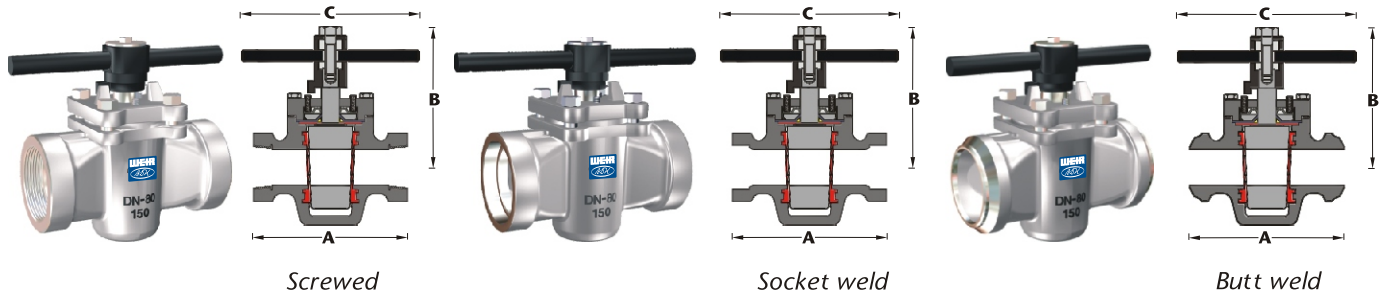

## Applications (Standard Plug valves)

- Chemical Process Plants
- Fertilizer Plants
- Dyes and Pigments
- Pesticides
- Caustic Chlorine Plants
- Hazardous Fluids
- Acids and Alkalies

## Applications (Caged Plug valves)

- Phosphoric Acid Slurry
- Titanium Dioxide Slurry
- Suspended Solid Slurries
- Uranium Ore Slurries
- Caustic Soda & Lime Slurry
- Heavy Black Liquor
- Fly Ash

## Test pressure in bar (psi)

Pressure rating	Class 150	Class 300	Class 600
Hyd. Shell	30 (435)	76 (1102)	158 (2292)
Seat	22 (319)	56 (812)	110 (1595)
Air Seat	← 7.0 (102) →		

Design STD : API 599, BS 5353 & API 6D

Testing STD : API 598 & EN 12266-1

Dimensions are in mm (inch)

Size mm (inch)	← A →		B	C	← Wt 1) →	
	SE, SWE & BWE	Extended BWE			SE, SWE & BWE	Extended BWE
15 (1/2)	83 (3.3)	250 (9.8)	95 (3.7)	225 (8.9)	1.7 (3.5)	2.0 (4.5)
20 (3/4)	83 (3.3)	250 (9.8)	100 (3.9)	225 (8.9)	1.9 (4.0)	2.3 (5.0)
25 (1)	117 (4.6)	280 (11.0)	110 (4.3)	225 (8.9)	3.5 (8.0)	4.0 (9.0)
32 (1 1/4)	140 (5.5)	330 (13.0)	110 (4.3)	325 (12.8)	4.0 (9.0)	4.5 (10.0)
40 (1 1/2)	140 (5.5)	330 (13.0)	120 (4.7)	325 (12.8)	4.5 (10.0)	5.0 (11.0)
50 (2)	165 (6.5)	360 (14.2)	145 (5.7)	450 (17.7)	7.5 (17.0)	8.0 (18.0)
65 (2 1/2)	190 (7.5)	400 (15.7)	141 (5.6)	450 (17.7)	8.5 (19.0)	9.0 (20.0)
80 (3)	203 (8)	425 (16.7)	160 (6.3)	450 (17.7)	11.0 (24.0)	12.0 (27.0)

## Materials

Body & Cover <b>2)</b>	Ductile Iron ASTM A395/ Steel ASTM A216 Gr. WCB/ ASTM A351 Gr. CF8 / CF8M / CN7M
Plug	Steel ASTM A217 Gr. CA15 / ASTM A351 Gr. CF8 / CF8M / CN7M
Sleeve / Diaphragm	PTFE / CFT / GFT
Wedge Ring	PTFE / CFT / GFT / Grafoil <b>4)</b>
Metal Diaphragm / Static Eliminator	ASTM A240 Type 304
Thrust Collar	ASTM A351 Gr. CF8
Adjusting Screws	ASTM A276 Type 304
Fasteners	SS 304
Adapter / Lever	Steel - Powder coated
Gear Unit	Housing in Cast Iron, Gear in S. G. Iron and Worm in EN8
Bearing <b>3)</b>	PTFE
Body Gasket <b>4)</b>	Grafoil
Surface Protection for Ductile Iron and Cast Carbon Steel Valves	Prime Coat : Chlorine free with modified alkyd resin unobjectionable in physiological and toxicological respects. Additional External Coating : Synthetic Enamel.

1) Nett in kg.(lbs) approx. (without obligation) 2) DI material for class 150, Screwed ends Non Fire-safe design only. 3) For Caged valves only. 4) For Fire-safe valves only. • Standard screwed ends to have BS:21 (parallel or taper) or ANSI / ASME B1.20.1 (NPT) threads. Socket weld ends as per ASME B16.11 & Butt weld ends as per ASME B16.25 suitable for schedule 40 / 80. • Please specify working pressure, temperature & service conditions. • Valves can be supplied with Locking, Extended Stem / Electrical / Pneumatic Actuators, & accessories like Limit Switch, Solenoid Valve, Air Filter Regulator, Positioner etc. • Other materials not mentioned above available on request.

# Sleeved Plug Valves

3 way, class 150, 300 & 600

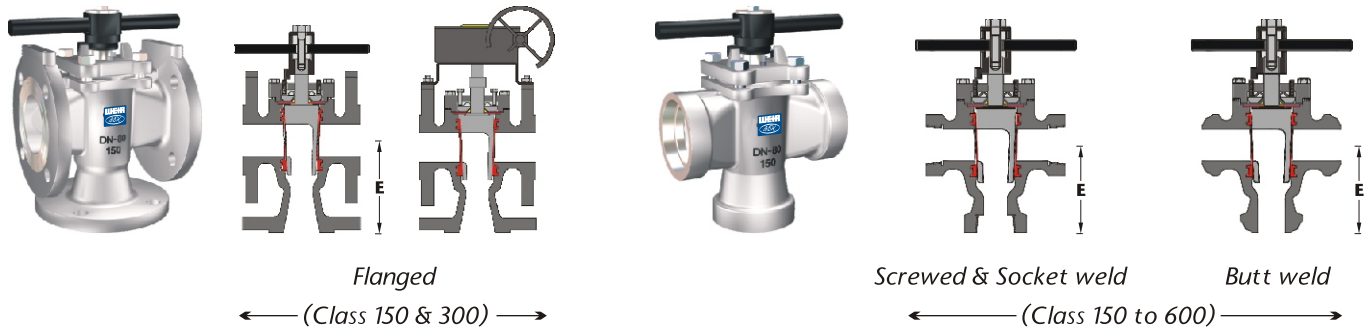

Dimensions are in mm (inch)

Flanged Size mm (inch)	E		Wt 1)		Screwed, Socket & Butt weld	
	Class 150	Class 300	Class 150	Class 300	E Class 150 & 300	Wt 1)
15 (1/2)	70 (2.8)	73 (2.9)	3.0 (7)	5.0 (11)	43 (1.7)	2.5 (6)
20 (3/4)	73 (2.9)	76 (3.0)	3.5 (8)	7.5 (17)	57 (2.2)	3.0 (7)
25 (1)	89 (3.5)	95 (3.7)	5.5 (12)	9.0 (20)	60 (2.4)	4.2 (9)
32 (1 1/4)	95 (3.7)	105 (4.1)	7.5 (17)	12.0 (27)	73 (2.9)	5.0 (11)
40 (1 1/2)	105 (4.1)	110 (4.3)	9.5 (21)	16.0 (35)	73 (2.9)	5.3 (12)
50 (2)	114 (4.5)	120 (4.7)	15.0 (33)	22.0 (49)	86 (3.4)	8.5 (19)
65 (2 1/2)	130 (5.1)	140 (5.5)	16.0 (35)	23.0 (51)	95 (3.7)	10.5 (23)
80 (3)	130 (5.1)	140 (5.5)	24.0 (53)	32.0 (71)	105 (4.1)	12.0 (27)
100 (4)	152 (6.0)	170 (6.7)	40.0 (88)	60.0 (132)	-	-
125 (5)	172 (6.8)	192 (7.6)	52.0 (115)	93.0 (205)	-	-
150 (6)	190 (7.5)	216 (8.5)	70.0 (154)	115 (254)	-	-
200 (8)	230 (9.1)	255 (10.0)	115 (254)	182 (401)	-	-
250 (10)	280 (11.0)	310 (12.2)	172 (379)	260 (573)	-	-
300 (12)	320 (12.6)	350 (13.8)	240 (529)	310 (683)	-	-
350 (14)	350 (13.8)	-	360 (794)	-	-	-
400 (16)	390 (15.4)	-	715 (1575)	-	-	-
450 (18)	430 (16.9)	-	1015 (2238)	-	-	-

1) Nett in Kg. (lbs) Approx. (without obligation) ■ For other details refer previous pages.

## Flow patterns

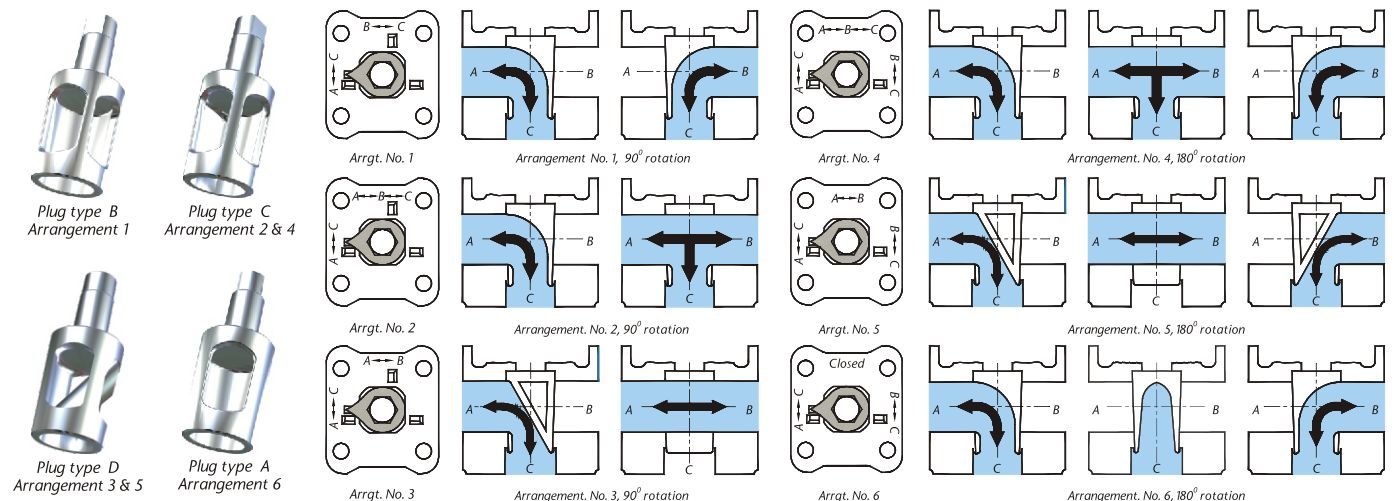

# Sleeved Plug Valves

## Fully & partially jacketed

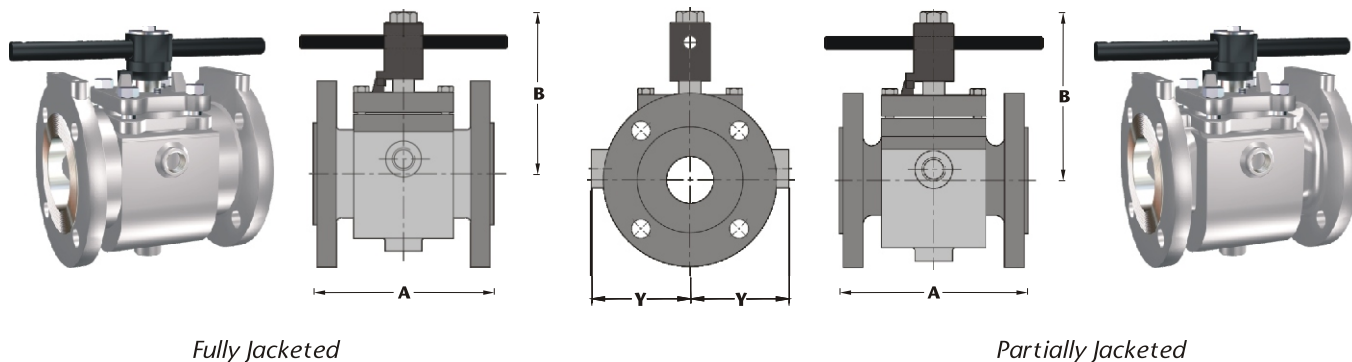

## Applications

- Molten Sulphur
- Bitumen (Coal Tar)
- For heating and cooling of fluids

## Dimensions are in mm (inch)

Size ← mm (inch) →	Flange Size	← A →		Y	Partially jacketing ← Wt 1 →		Fully jacketing ← Wt 1 →		Class - 150 & 300 ← B →	
		Class 150	Class 300		Class 150	Class 300	Class 150	Class 300	Partially jacketing	Fully jacketing
15 (1/2)	25 (1)	108 (4.3)	140 (5.5)	35 (1.4)	2.0 (4)	3.5 (8)	3.0 (7)	6.5 (14)	95 (3.7)	125 (4.9)
20 (3/4)	40 (1 1/2)	117 (4.6)	152 (6.0)	40 (1.6)	2.5 (6)	5.0 (11)	4.5 (10)	8.0 (18)	100 (3.9)	130 (5.1)
25 (1)	50 (2)	140 (5.5)	165 (6.5)	45 (1.8)	4.5 (10)	6.5 (14)	7.5 (17)	10.0 (22)	110 (4.3)	142 (5.6)
32 (1 1/4)	50 (2)	165 (6.5)	178 (7.0)	45 (1.8)	6.0 (13)	9.0 (20)	9.0 (20)	14.0 (31)	110 (4.3)	142 (5.6)
40 (1 1/2)	65 (2 1/2)	165 (6.5)	190 (7.5)	50 (2.0)	7.5 (17)	11.0 (24)	10.0 (22)	16.0 (35)	120 (4.7)	148 (5.8)
50 (2)	80 (3)	178 (7.0)	216 (8.5)	60 (2.4)	12.0 (27)	16.0 (35)	15.0 (33)	20.0 (44)	145 (5.7)	175 (6.9)
65 (2 1/2)	100 (4)	190 (7.5)	241 (9.5)	70 (2.8)	15.0 (33)	18.0 (40)	18.0 (40)	24.0 (53)	141 (5.6)	180 (7.1)
80 (3)	100 (4)	203 (8.0)	283 (11.1)	70 (2.8)	18.0 (40)	22.0 (49)	24.0 (53)	30.0 (66)	160 (6.3)	188 (7.4)
100 (4)	150 (6)	229 (9.0)	305 (12.0)	80 (3.1)	30.0 (66)	44.0 (97)	37.0 (82)	54.0 (119)	195 (7.7)	235 (9.3)
125 (5)	150 (6)	254 (10.0)	381 (15.0)	80 (3.1)	51.0 (113)	78.0 (172)	55.0 (121)	88.0 (194)	236 (9.3)	235 (9.3)
150 (6)	200 (8)	267 (10.5)	403 (15.9)	115 (4.5)	60.0 (132)	91.0 (201)	80.0 (176)	115.0 (254)	250 (9.8)	250 (9.8)
200 (8)	250 (10)	292 (11.5)	419 (16.5)	130 (5.1)	96.0 (211)	148.0 (326)	125.0 (276)	170.0 (375)	280 (11.0)	280 (11.0)
250 (10)	300 (12)	330 (13.0)	457 (18.0)	145 (5.7)	142.0 (313)	210.0 (463)	160.0 (353)	260.0 (573)	340 (13.4)	340 (13.4)
300 (12)	350 (14)	356 (14.0)	502 (19.8)	150 (5.9)	195.0 (430)	-	230.0 (507)	-	390 (15.4)	390 (15.4)
350 (14)	400 (16)	381/686 (15.0/27.0)	-	165 (6.5)	325.0 (717)	-	330.0 (728)	-	450 (17.7)	450 (17.7)
400 (16)	500 (20)	762 (30.0)	-	265 (10.4)	650.0 (1433)	-	670.0 (1477)	-	595 (23.4)	595 (23.4)
450 (18)	500 (20)	864 (34.0)	-	300 (11.8)	998.0 (2200)	-	1050.0 (2315)	-	650 (25.6)	650 (25.6)

1) Nett in kg. (lbs) approx. (without obligation) • Size 15mm (1/2") to 100mm (4") lever operated, size 125mm (5") & above gear operated. • Jacket test pressure 7 bar (102 psi). • Higher size flange for fully jacketed valves only. • Standard jackets are carbon steel. • Inlet / outlet / drain connection: 1/4" NPT for sizes 15mm (1/2") to 40mm (1 1/2"), 1/2" NPT for 50mm (2") to 100mm (4"), 3/4" NPT for 125mm (5") to 200mm (8") & 1" NPT for 250mm (10") & above. • For other details refer previous pages.

# Sleeved Plug Valves

## Construction details

Weir BDk'S range of Sleeved Plug valves are designed for high standard of performance. These tight shut-off, bi-directional valves with cavity-free passage can be used on both pressure and vacuum services and ensure long-term reliable operation with simplified in-line maintenance.

Standard design

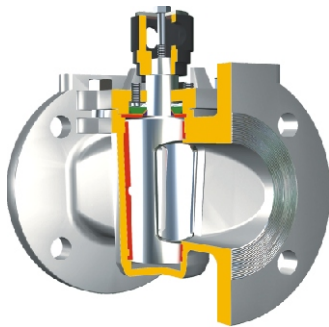

Sleeve is positively locked with the locking ribs in the body, ensures leak tight shut-off.

Standard caged design

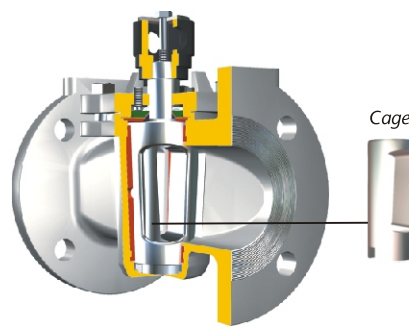

Protects the Sleeve from direct flow impingement in throttling position.

## Seal arrangement

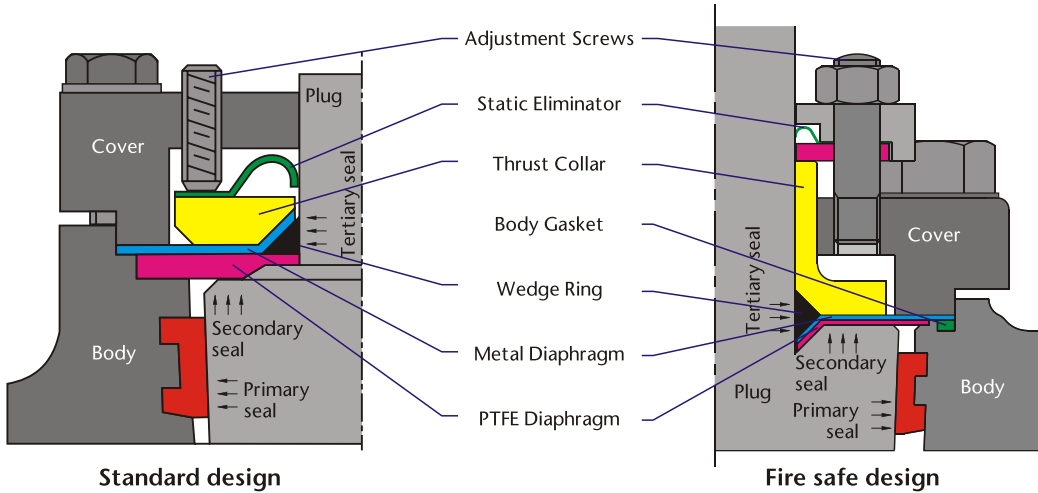

## Fire safe test

Weir BDk Sleeved Plug valves are successfully fire tested in accordance with API 607 & API 6FA for external sealing requirements of section 4, paragraph 4.2, performance requirements certified by BVQI Industrial services.

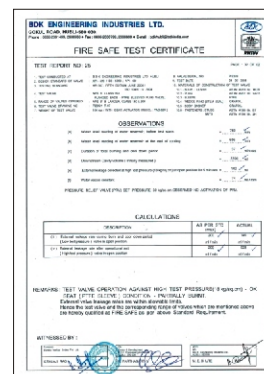
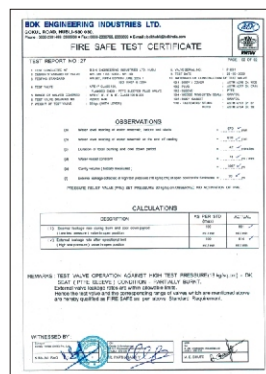
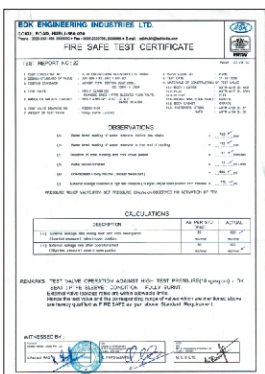

Fire-safe test certificates

# Lined Plug Valves

## Valve parts

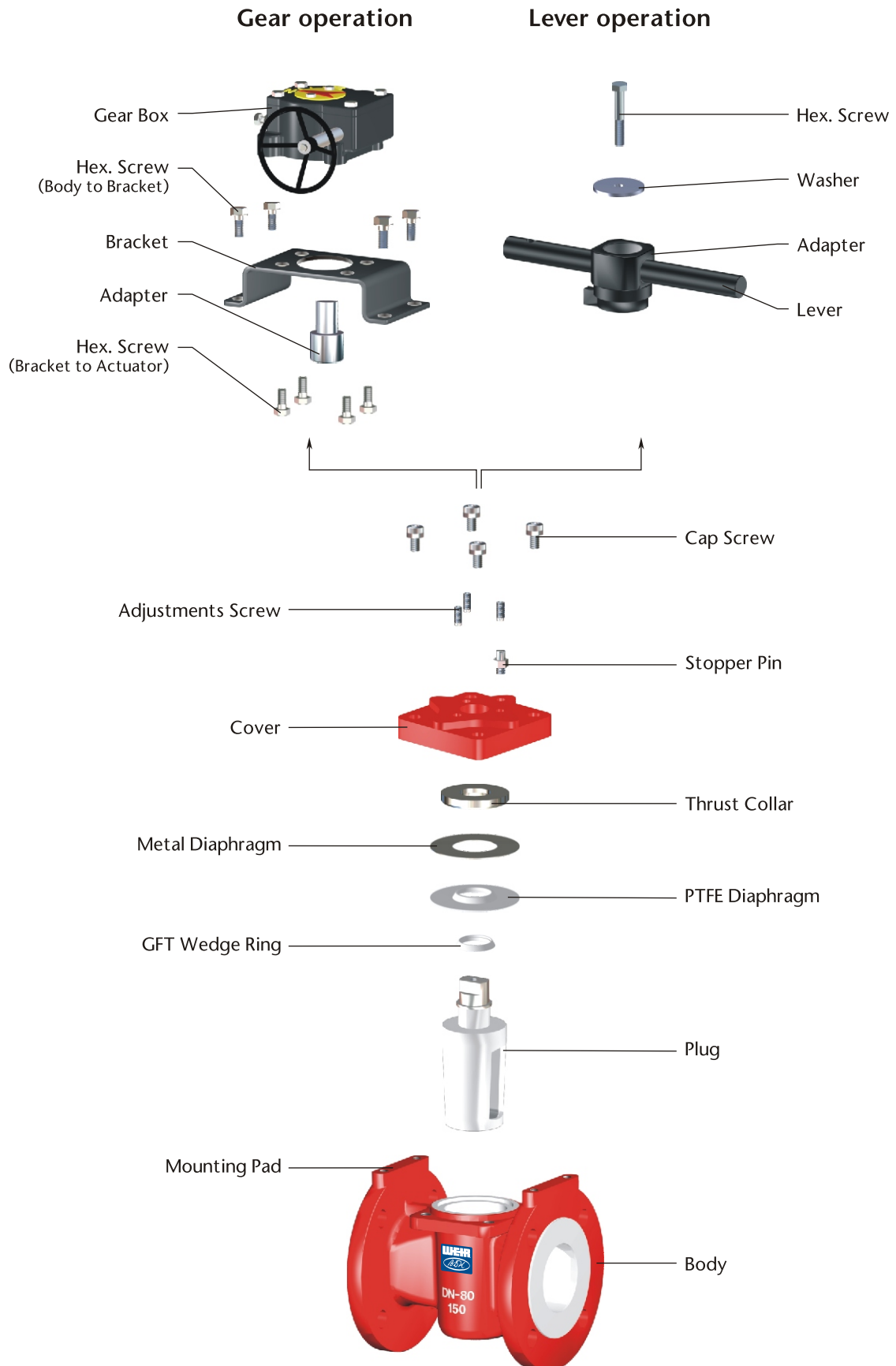



# Lined Plug Valves

## Class 150 & PN10

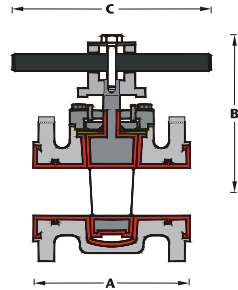

## Applications

### Highly corrosive fluids such as

- Hydrochloric Acid
- Sulphuric Acid
- Semiconductor Applications
- Nitric Acid
- Wet & Dry Chlorine
- Phosphoric Acid

## Test pressure in bar (psi)

Pressure rating	Class 150	PN10
Hyd. Shell	26 (377)	15 (218)
Seat	16 (232)	11 (160)
Air Seat	6 (87)	5 (73)

Design STD : API 599, BS 5353 & BS 5158

Testing STD : API 598 & EN 12266-1

## Dimensions are in mm (inch)

Size mm (inch)	A B16.10	B	C	Wt 1)
15 (1/2)	108 (4.3)	108 (4.3)	325 (12.8)	1.8 (4.0)
20 (3/4)	117 (4.6)	115 (4.5)	325 (12.8)	2.5 (5.5)
25 (1)	127 (5.0)	122 (4.8)	325 (12.8)	4.2 (9.3)
40 (1 1/2)	165 (6.5)	148 (5.8)	450 (17.7)	7.0 (15)
50 (2)	178 (7.0)	135 (5.3)	450 (17.7)	10 (22)
65 (2 1/2)	190 (7.5)	145 (5.7)	450 (17.7)	16 (35)
80 (3)	203 (8.0)	167 (6.6)	750 (29.5)	19 (42)
100 (4)	229 (9.0)	210 (8.3)	750 (29.5)★★	33 (73)
150 (6)	267 (10.5)	★	★	62 (137)
200 (8)	292 (11.5)	★	★	92 (203)

## Materials

Body & Cover	Ductile Iron ASTM A395 Gr. 60-40-18 / S.G. Iron EN-1563 No.EN-151024 Steel : ASTM A216 Gr. WCB / Stainless Steel ASTM A351 Gr. CF8 / CF8M
Plug	Stainless Steel ASTM A747 Gr. CB7Cu-1 (17-4PH)
Body & Plug Lining	PFA / FEP
Diaphragm / Wedge Ring	PTFE / GFT
Metal Diaphragm	Stainless Steel ASTM A240 TYPE 304
Thrust collar / Fasteners	Stainless Steel ASTM A276 TYPE 304
Adapter / Lever	Steel
Surface Protection for Ductile Iron and Cast Carbon Steel Valves	Prime Coat : Chlorine free with modified alkyd resin unobjectionable in physiological and toxicological respects. Additional External Coating : Enamel Red.

1) Nett in kg. (lbs) approx. (without obligation) ★ Gear operation. ★★ Gear operation recommended. • Pressure rating : PN10 for sizes 150mm (6") & above. • Valves can be supplied to suit ASME / BS / DIN flanges. • Please specify working pressure, temperature & service conditions. • Valves can be supplied with Locking, Extended Stem / Electrical / Pneumatic Actuators, & accessories like Limit Switch, Solenoid Valve, Air Filter Regulator, Positioner etc. • Other materials not mentioned above available on request.

# Sleeved Plug Valves

## Features

- **Zero leakage**  
With primary sealing by sleeve (lining in case of lined plug valve), secondary sealing by diaphragm and tertiary sealing by wedge ring, the plug valve assures zero leakage of the fluid flowing through the system.
- **Secure sealing**  
The sleeve is positively locked in the body with the locking ribs located in the body to assure secure sealing.
- **Cavity free**  
There are no cavities in the body, the plug is surrounded completely by sleeve, so there is no possibility of fluid accumulation and contaminate feature processing. This cavity-free design also prevents sticking.
- **Non lubrication**  
The PTFE sleeves have a low coefficient of friction and acts on a lubricant. Hence ease of operation is assured even though valve unopened for a period.
- **Low maintenance**  
The sealing pressure can be regenerated by the adjustment bolts provided on the cover without disassembly for repair. On line repair is easy as the plug is top entry type which will reduce the shutdown time of the plant.
- **Superior in line sealing**  
The plug is completely surrounded by the sleeve, providing a large circumferential sealing surface from port to port.
- **Self cleaning plug**  
As the plug rotates, the port lips located throughout 360° provide a self cleaning action to remove stealing and adhering media, facilitates no seizing and no sticking.
- **Adjustable sealing**  
When seal presence adjustment is required due to sleeve wear, slight rotation of adjustment bolts pushes the plug downwards thereby providing extra sealing pressure.
- **Antistatic electricity**  
Static eliminator (only in case of sleeved plug valves) is always in contact with the plug and releases the static electricity generated from the free floating fluid to the pipeline.
- **Compact design**  
Taper plug with trapezoidal shaped port, one piece body and less number of parts required to construct the valve make a compact and cost effective plug valve.

## Advantage of Caged Plug valves

Caged Plug valves

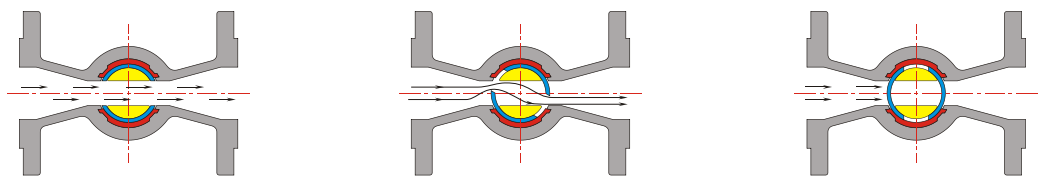

Sleeved Plug valves

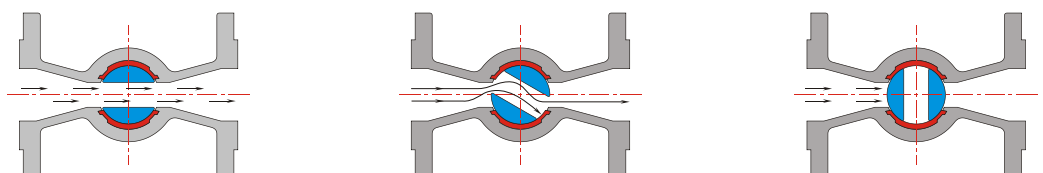

- Bubble tight shut-off across the seat due to metal to soft seat sealing.
- Metal to metal contact during throttling.
- During on-off position, soft seat is completely protected by plug.
- During throttling position, soft seat is protected by cage.
- Cage opening is matched to plug opening to give equal percentage flow characteristic for control applications.
- Hardened cages are available for increased life.

# Sleeved & Lined Plug Valves

## Technical data

### Pressure temperature rating

PTFE sleeve

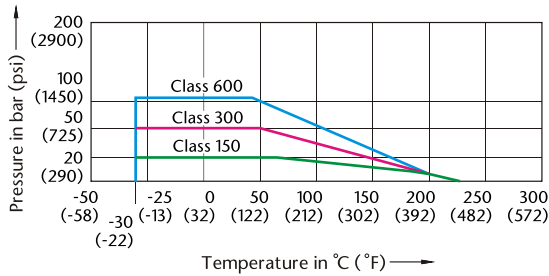

GFT/CFT sleeve

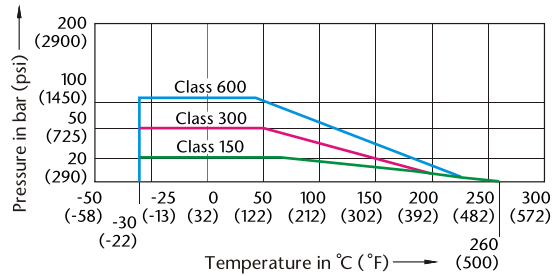

PFA lined class 150

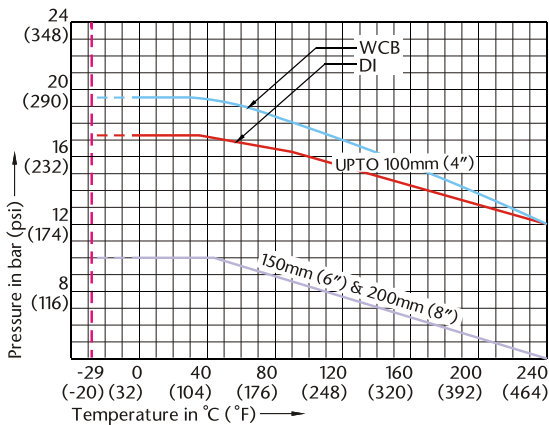

Flow characteristic

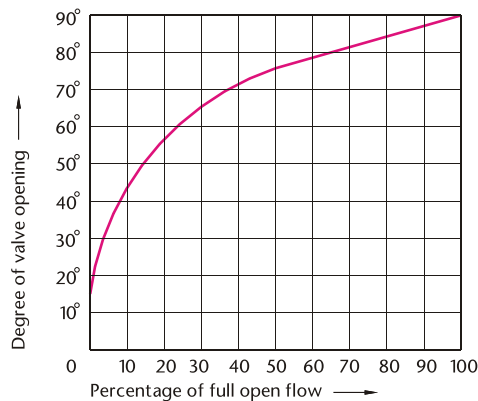

### Cv value

SIZE mm (inch)	Cv
15 (1/2)	9
20 (3/4)	14
25 (1)	44
32 (1 1/4)	66
40 (1 1/2)	92
50 (2)	175
65 (2 1/2)	245
80 (3)	290
100 (4)	545
125 (5)	650
150 (6)	1070
200 (8)	1580
250 (10)	2165
300 (12)	3159
350 (14)	3250
400 (16)	6200
450 (18)	8695

### Break away torque value Nm (ft. lbs.)

Size mm (inch)	PTFE sleeved		PFA lined Class 150 *
	Class 150*	Class 300**	
15 (1/2)	18 (13)	25 (19)	18 (13)
20 (3/4)	20 (15)	35 (26)	20 (15)
25 (1)	23 (17)	36 (27)	-
32 (1 1/4)	30 (22)	37 (27)	-
40 (1 1/2)	37 (27)	39 (29)	45 (33)
50 (2)	46 (34)	59 (44)	65 (48)
65 (2 1/2)	70 (52)	87 (64)	90 (67)
80 (3)	95 (70)	117 (86)	120 (89)
100 (4)	150 (111)	195 (144)	230 (170)
125 (5)	285 (210)	330 (244)	-
150 (6)	380 (280)	455 (336)	421 (311)***
200 (8)	680 (502)	805 (594)	550 (406)***
250 (10)	1100 (812)	1650 (1218)	-
300 (12)	1650 (1218)	3560 (2627)	-
350 (14)	2250 (1661)	-	-
400 (16)	5130 (3786)	-	-
450 (18)	8460 (6243)	-	-

★ ΔP 20 bar (290 psi), \*\* ΔP 51 bar (740 psi), \*\*\* ΔP 10 bar (145 psi)

### Actuator selection

Multiply the torque values by following factors 'F' to get the actuator torque.

Service	Factor 'F'
Raw water	1.35
Wet services	1.35
Steam	1.25
Gas	1.40
Slurry	1.80
Viscous liquid	2.0
High viscous liquid	3.0

**Weir BDK Valves**

47/48, Gokul Road, Hubli - 580 030. INDIA  
Telephone: +91-836-4248222 / 2333930  
Facsimile: +91-836-4248484 / 2330799  
E-mail: sales.weirbdk@weirgroup.com  
www.weirpowerindustrial.com

A unit of Weir India Private Limited  
(Formerly BDK Engineering Industries Limited)

Excellent  
Engineering  
Solutions

