

# Globe Valves - ASME Class 150, 300 & 600

Figure Numbers 413-8, 433-8 & 463-8

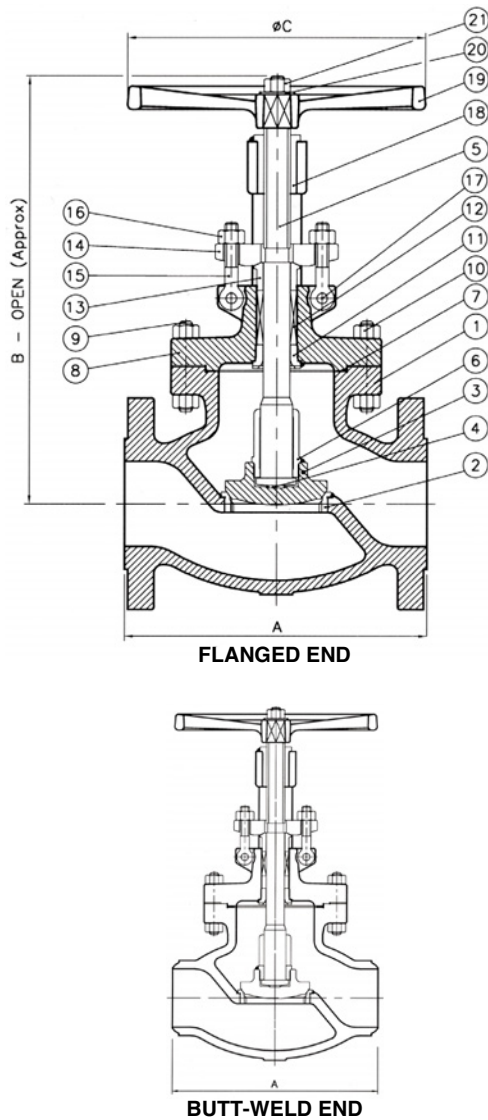

## Standard Materials of Construction

Sl. No.	Description	Material
01	Body	ASTM A216 Gr. WCB
02	Body Seat Ring	ASTM A182 Gr. F6a+HF
03	Disc	ASTM A216 Gr. WCB + 13% Cr. Steel
04	Disc Washer	13% Cr. Steel
05	Stem	ASTM A182 Gr. F6a
06	Disc Stem Nut	13% Cr. Steel
07	Gasket	ASTM A308
08	Bonnet	ASTM A216 Gr. WCB
09	Stud	ASTM A193 Gr. B7
10	Stud Nut	ASTM A194 Gr. 2H
11	Back-seat Bush	13% Cr. Steel
12	Packing	Graphite with braided end rings
13	Gland	13% Cr. Steel
14	Gland Flange	ASTM A105 / ASTM A216 Gr. WCB
15	Eye Bolt	Cr. - Mo Steel
16	Eye Bolt Nut	ASTM A194 Gr. 2H
17	Groove Pin	Steel
18	Yoke Bush	ASTM A439 Type D2
19	Handwheel	Steel / Ductile Iron / Malleable Iron
20	Washer	Steel
21	Handwheel Nut	ASTM A563 Gr. B
	Nameplate	SS 304

\* HF - Hard-Faced with Stellite #6 or equivalent  
For other body / bonnet materials, refer page 5

## Dimensions (in mm, unless specified) & Weights (in kg)

Valve Size	Class 150						Class 300						Class 600					
	A		B	C	Approx. Wt.		A		B	C	Approx. Wt.		A		B	C	Approx. Wt.	
	Fl.	B/W			Fl.	B/W	Fl.	B/W			Fl.	B/W	Fl.	B/W			Fl.	B/W
50 (2")	203	203	335	203	23	20	267	267	355	203	33	28	292	292	400	254	42	38
65 (2 1/2")	216	-	355	203	35	-	292	-	410	203	46	-	-	-	-	-	-	-
80 (3")	242	242	421	254	41	38	317	317	457	254	58	50	356	356	560	356	75	60
100 (4")	292	292	477	254	66	62	356	356	556	356	97	84	432	432	593	406	136	116
150 (6")	406	406	575	356	118	110	445	445	668	457	186	164	559	559	837	610	245	195
200 (8")	495	495	680	457	207	195	559	559	830	610	329	296	661	661	947	610	546	466
250 (10")	623	623	895	356	335	320	623	623	1206	610	520	471	787	787	1285	762	756	656
300 (12")	699	699	1215	610	495	470	711	711	1160	762	705	634	838	838	1560	762	1086	896

Fl. - Flanged ; B/W - Butt-weld.

# Globe Valves - ASME Class 900 & 1500

Figure Numbers 493-8 & 4A3-8

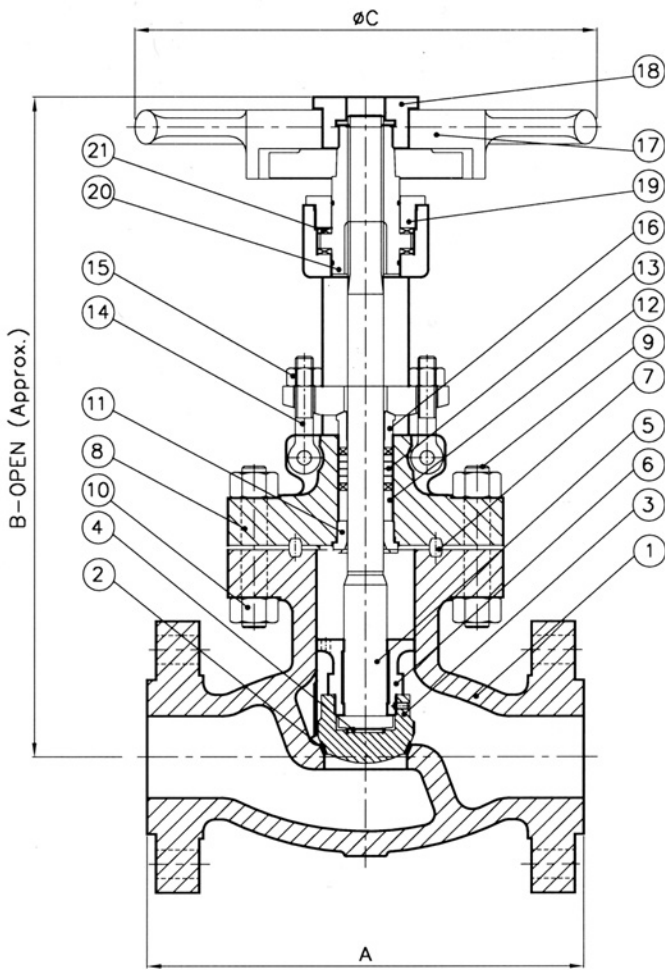

FLANGED END

## Standard Materials of Construction

Sl. No.	Description	Material
01	Body	ASTM A216 Gr. WCB
02	Body Seat	Integral Stellite #6 or eq.
03	Disc	ASTM A216 Gr. WCB + 13% Cr. Steel
04	Disc Washer	13% Cr. Steel
05	Stem	ASTM A182 Gr. F6a
06	Disc Stem Nut	13% Cr. Steel
07	Gasket RTJ	SS 316
08	Bonnet	ASTM A216 Gr. WCB
09	Stud	ASTM A193 Gr. B7
10	Stud Nut	ASTM A194 Gr. 2H
11	Back-seat Bush	13% Cr. Steel
12	Spacer	13% Cr. Steel
13	Packing	Graphite with braided end rings
14	Eye Bolt	ASTM A193 Gr. B7
15	Eye Bolt Nut	ASTM A194 Gr. 2H
16	Gland	13% Cr. Steel
17	Handwheel	Steel / Ductile Iron /
18	Handwheel Nut	Malleable Iron
19	Retainer Nut	
20	Yoke Sleeve	ASTM A439 Type D2
21	Bearing	Steel
	Nameplate	SS 304

\* HF - Hard-Faced with Stellite #6 or equivalent  
For other body / bonnet materials, refer page 5

## Dimensions (in mm, unless specified) & Weights (in kg)

Valve Size	Class 900						Class 1500					
	A		B	C	Approx. Wt.		A		B	C	Approx. Wt.	
	Fl.	B/W			Fl.	B/W	Fl.	B/W			Fl.	B/W
50 (2")	-	-	-	-	-	-	368	368	590	305	110	85
80 (3")	381	381	700	305	138	120	470	470	720	305	255	195
100 (4")	457	467	800	356	216	180	546	546	850	356	315	265
150 (6")	610	610	1100	508	426	395	-	-	-	-	-	-

Fl. - Flanged ; B/W - Butt-weld.