

# Trunnion Mounted Ball Valves





# CONTENTS

Product Coding for KITZ Trunnion Mounted Ball Valves	2
Soft seated	2
Metal seated	2
<b>Soft Seated 3-Piece Body Trunnion Mounted Ball Valves T60S Series<sup>(1)</sup></b>	<b>3</b>
Component Drawing	4
Design Features	5
Construction and Materials	7
Valve Dimensions and Operators	9
Material Example	11
Dimensions of Actuator Mounting Pads	12
<b>Metal Seated 3-Piece Body Trunnion Mounted Ball Valves T60M Series<sup>(1)</sup></b>	<b>15</b>
Component Drawing	16
Design Features	17
Construction and Materials	18
Valve Dimensions and Operators	20
Pressure-Temperature Ratings	22
Engineering Data	23
<b>Soft Seated 3-Piece Body Trunnion Mounted Ball Valves F18TK-T60 Series<sup>(2)</sup></b>	<b>25</b>
Design Features	28
Material Example/Pressure-Temperature Rating	30
Dimensions	31
Engineering Data	35

Note: (1) Made in Japan  
 (2) Made in Spain

**KITZ / KITZ CORPORATION** are registered trademarks

# Product Coding for KITZ Trunnion Mounted Ball Valves

## Soft seated

Example **T60S / G-150 SF3TC S BL 8**  
**T60S / G-150 UF3TC S M 8**

①
②
③
④
⑤
⑥
⑦

①	T60S	Series code for soft seated	
	- None	Lever operation	
②	- G	Gear operation	
	- B	KITZ Type B double acting pneumatic actuator	
	- BS	KITZ Type BS spring return pneumatic actuator	
③	Pressure class	150, 300, 600, 900 or 1500	
④	- SF3TC	Trunnion ball valve made in carbon and low alloy steel	
	- UF3TC	Trunnion ball valve made in stainless and high alloy steel	
⑤	- S	Full bore (fire safe)	
	- RS	Reduced bore (fire safe)	
⑥	Body & Trim material: Other materials are also available		
	- None	150-600	A105 Body/Cap/Ball, 316SS Stem
		900/1500	A105 Body/Cap, F60 Ball, 316SS Stem
	- BL	150-600	LF2 Body/Cap/Ball, 316SS Stem
		900/1500	LF2 Body/Cap, F60 Ball, 316SS Stem
	- M	150-600	F316 Body/Cap/Ball, 316SS Stem
900/1500		F316 Body/Cap, F51 or S31803 Ball, 316SS Stem	
⑦	Nominal size (NPS)	2 to 24	

## Metal seated

Example **T60M / G-150 SF3TC 6H 10**  
**T60M / G-150 UF3TC 6H M 10**

①
②
③
④
⑤
⑥
⑦
⑧

①	T60M	Series code for metal seated	
	- None	Lever operation	
②	- G	Gear operation	
	- B	KITZ Type B double acting pneumatic actuator	
	- BS	KITZ Type BS spring return pneumatic actuator	
③	Pressure Class	150, 300 or 600	
④	- SF3TC	Trunnion ball valve made in carbon steel	
	- UF3TC	Trunnion ball valve made in stainless steel	
⑤	- None	Full bore	
	- R	Reduced bore	
⑥	6H	Metal seated trunnion ball valve	
⑦	Body & Trim material: Other materials are also available		
	- None	A105 Body/Cap, 316SS Ball, 630SS Stem	
	- BL	LF2 Body/Cap, 316SS Ball, 630SS Stem	
	- M	316SS Body/Cap/Ball, 630SS Stem	
⑧	Nominal size (NPS)	2 to 24	

## T60S Series

### Soft Seated 3-Piece Body Trunnion Mounted Ball Valves



#### DESIGN STANDARDS

- Basic design: API 6D/ISO 14313
- F-F dimensions: API 6D/ASME B16.10
- End connection: ASME B16.5
- Bore diameter: API 6D/ISO 14313
- Wall thickness: ASME PBVC Section VIII

#### CERTIFICATION

- Fugitive emission: ISO 15848-1 BH CO1
- Fire test: API 607/API 6FA/ISO 10497
- PED: 2014/68/EU
- ATEX: 2014/34/EU
- SIL: IEC 61508 (SIL 2)

#### PRODUCT RANGE

- Nominal pressure: ASME Class 150 to 1500
- Nominal size: NPS 2 to NPS 24 (DN 50 to DN 600)
- Shell materials:
  - Carbon steel, Alloy steel,
  - Austenitic stainless steel, Duplex stainless steel,
  - High alloy steel, Nickel based alloy
- Ball seat materials:
  - RPTFE (Reinforced PTFE), Modified PTFE,
  - RNylon (Reinforced Nylon), DEVLON V<sup>®</sup>,
  - PEEK

#### DESIGN FEATURES

- Structure: 3-piece bolted body and cap
- Standard material: NACE MR0175, ASTM and others
- Tight shut-off sealing mechanism
- Low operating torque
- Triple stem sealing system with 2 O-rings & Packing
- Double Block and Bleed function
- Self-relief of excessive cavity pressure
- Fire safe tested
- Blowout-proof ball seat & stem construction
- Antistatic provision design
- Locking device for lever operation
- ISO 5211 actuator mounting pad
- Available for DPE (Double Piston Effect)/SPE (Single Piston Effect)

## Component Drawing

### Up to size NPS 4

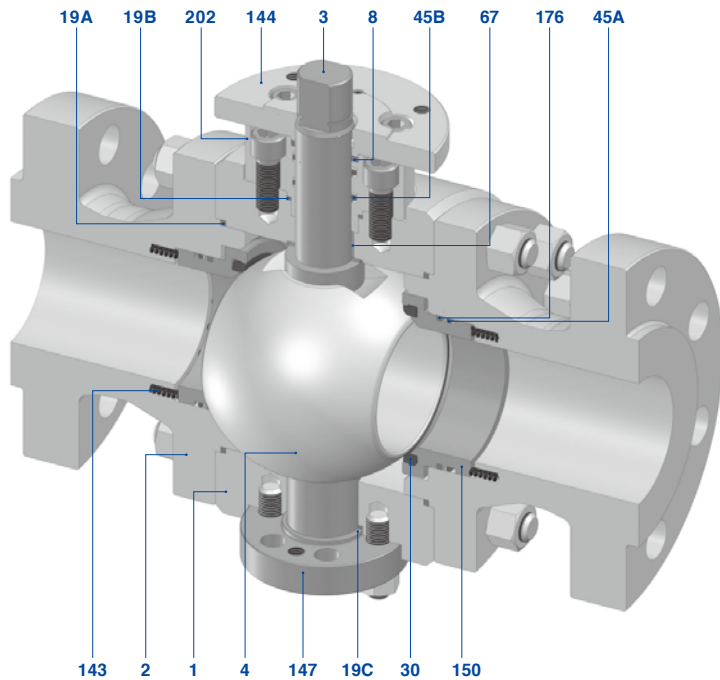

- 1 Body\*
- 2 Cap\*
- 3 Stem
- 4 Precision machined ball
- 8 Firesafe gland packing (Flexible graphite)
- 19A Gasket (Flexible graphite)
- 19B Gasket (Flexible graphite)
- 19C Gasket (Flexible graphite)
- 30 Ball seat
- 45A O-ring
- 45B O-ring
- 67 Stem bearing (Metal + RPTFE)
- 143 Seat spring
- 144 Gland plate
- 147 End plate
- 150 Seat retainer
- 176 Fire safe retainer packing (Flexible graphite)
- 202 Bonnet

\*Note: Made of forged carbon steel, low alloy steel and high alloy steel. Made of forged or cast austenitic stainless steel, duplex stainless steel and other special alloy materials. Contact KITZ for current available materials.

### Size NPS 6 and larger

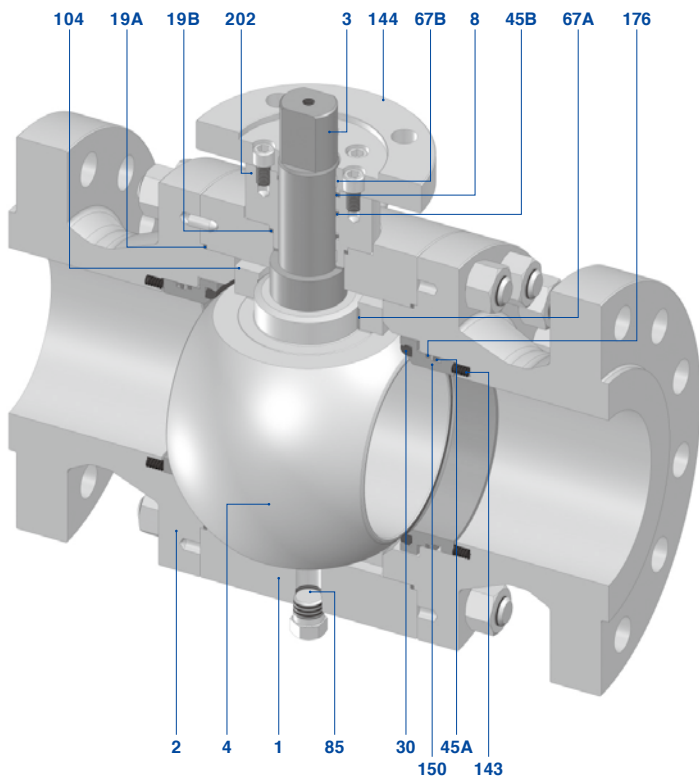

- 1 Body\*
- 2 Cap\*
- 3 Stem
- 4 Precision machined ball
- 8 Fire safe gland packing (Flexible graphite)
- 19A Gasket (Flexible graphite)
- 19B Gasket (Flexible graphite)
- 30 Ball seat
- 45A O-ring
- 45B O-ring
- 67A Curl bearing (Metal + RPTFE)
- 67B Stem bearing (PTFE)
- 85 Plug
- 104 Trunnion plate
- 143 Seat spring
- 144 Gland plate
- 150 Seat retainer
- 176 Fire safe retainer packing (Flexible graphite)
- 202 Bonnet

The illustration shown in this catalog represents the typical structure of Class 600 valves.

The structure may differ depending on sizes and classes. Please consult KITZ for more details on the specifications and structure of the valve.

# Design Features

## 1. Fire Safe Design

### (1) Internal Leakage Prevention

When resilient sealing materials are damaged or destroyed by a plant fire, edges of upstream and downstream metal seat retainers preloaded by seat springs come into contact with the ball to shut off line fluid to minimize internal leakage through the valve bore. And, flexible graphite seat retainer packing rings of KITZ original design prevent fluid leakage from between the valve caps and seat retainers during and after the plant fire.

### (2) External Leakage Prevention

External leakage from the valve stem area is prevented by double sealing with O-rings and flexible graphite gland packing rings. Leakage through the valve body joint is protected by flexible graphite gaskets. Even after a fire has deteriorated O-rings, flexible graphite gland packing rings and gaskets remain intact to prevent external fluid leakage.

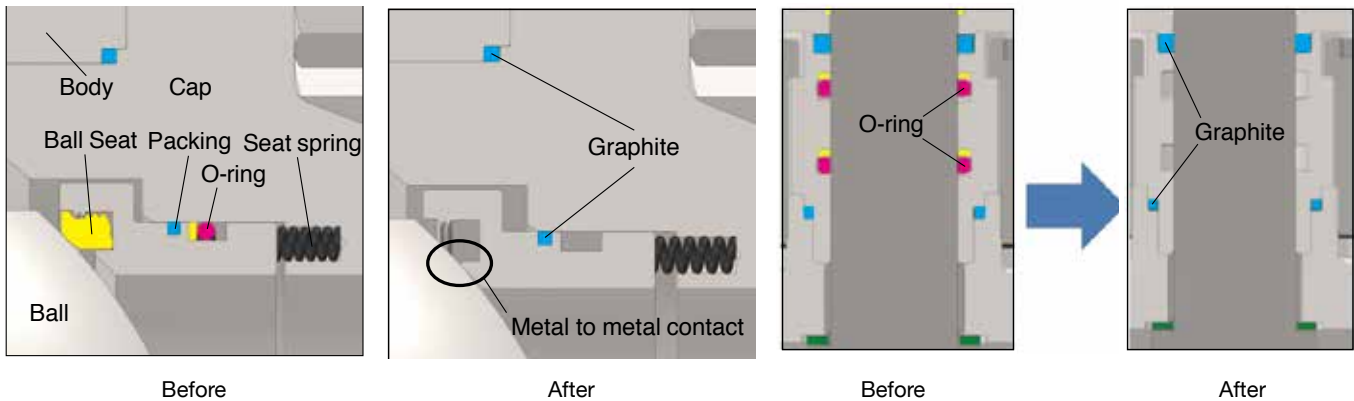

## 2. Tight Shut-off Sealing Mechanism

The resilient seat design adequately maintains each of the upstream and downstream ball seats in contact with the ball by means of repulsing force of seat springs inserted behind the seat retainers. Line fluid pressure also helps this contact method. This sealing mechanism features un failing thru-the-bore sealing performance of upstream and downstream side ball seats at the same time.

## 3. Double Block and Bleed Function

Ball seats independently shut off the line fluid on the upstream and downstream side of the ball. The valve bore and the body cavity are isolated from each other when the valve is fully open or closed. Under this condition, the cavity pressure can be discharged with a vent valve and a drain plug. The vent valve is equipped with a blowout-proof bleeder for safe discharge. Relieving the cavity pressure with a vent valve is recommended for safe draining.

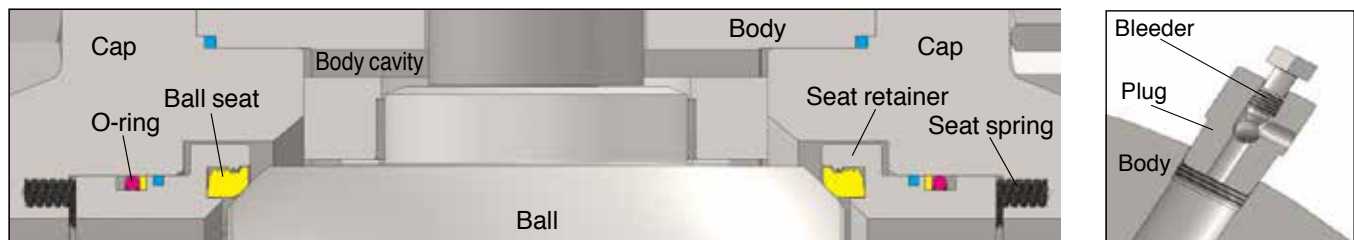

## Design Features

### 4. Blowout-proof Ball Seat Assembly

As illustrated below, ball seats are threaded into unthreaded back of seat retainers to finally reach to inner walls and lower shoulders of the seat retainers for tightly sealing surface-to-surface contact. This unique design provides easy maintenance and blowout-proof seat assembly when ball seats are excessively loaded by back pressure due to incidental cavity pressure rise.

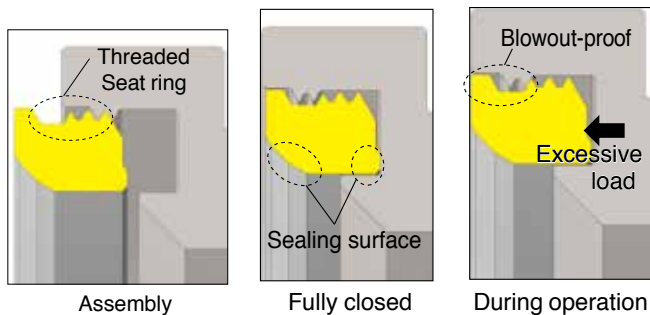

### 6. Cavity Pressure Relief

In case of incidental rise of servicing or ambient temperature, liquefied gas or highly volatile liquid trapped within the body cavity may vaporize, and cause an excessive rise in the cavity pressure. For safety consideration, when the cavity pressure exceeds the line pressure, either one of the ball seats will move slightly away from the ball surface together with seat retainers to relieve the excessive cavity pressure into the valve bore.

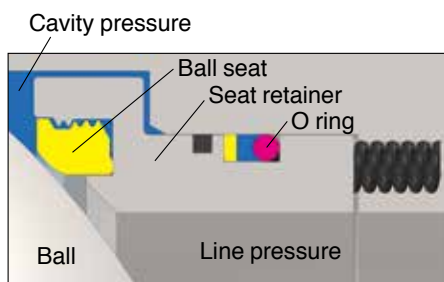

### 7. Low Emission Guaranteed Design

The fugitive emission suppressing design for both resilient and metal seated valves are certified to ISO 15848 tightness class "B" (Lower than  $10^{-4}$   $\text{mg}\cdot\text{s}^{-1}\cdot\text{m}^{-1}$  for stem leakage and lower than 50 ppmv for body leakage). This verifies the outstanding low emission performance of the whole sealing mechanism of the valve.

### 5. Antistatic Design

Spring loaded balls assembled between the stem and the bonnet and between the stem and the ball permits electric conductivity through all metallic valve components.

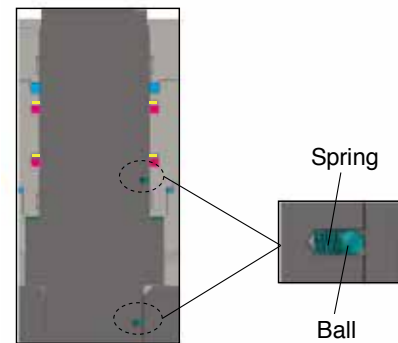

### 8. Options<sup>1</sup>

#### (1) Emergency Seal Restoration<sup>2</sup>

For accidental leakage from ball seats or stem sealing area, a sealant supply mechanism may be provided as an option. Should sealing parts be damaged or decomposed by a fire or other accidental causes, leakage can be temporarily prevented or reduced by sealant injection into this mechanism.

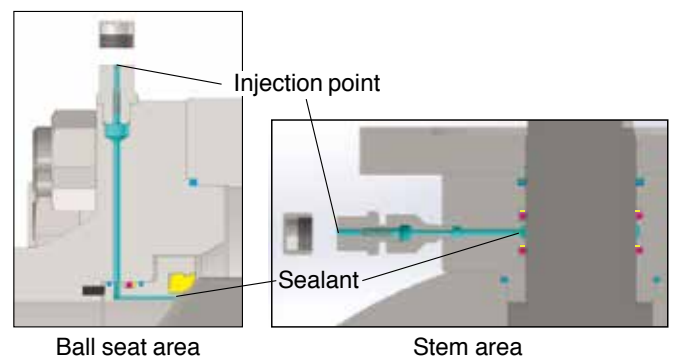

#### (2) Special Shell and Trim Materials

#### (3) Special Sealing Component Materials

#### (4) Butt-weld Piping Connection

#### (5) Pipe Pups Welded to Valve Ends

#### (6) DIB: Double Isolation and Bleed (Double Seal)<sup>3</sup>

#### (7) Stem Extension

#### (8) Overlay for Bore and Cavity

#### (9) Actuation (Pneumatic and Electric)

<sup>1</sup> For all optional provisions, please contact your local KITZ agents or distributors.

<sup>2</sup> Standard design for North America.

<sup>3</sup> Any combination of DPE (Double Piston Effect)/SPE (Single Piston Effect) is available.

## Construction and Materials

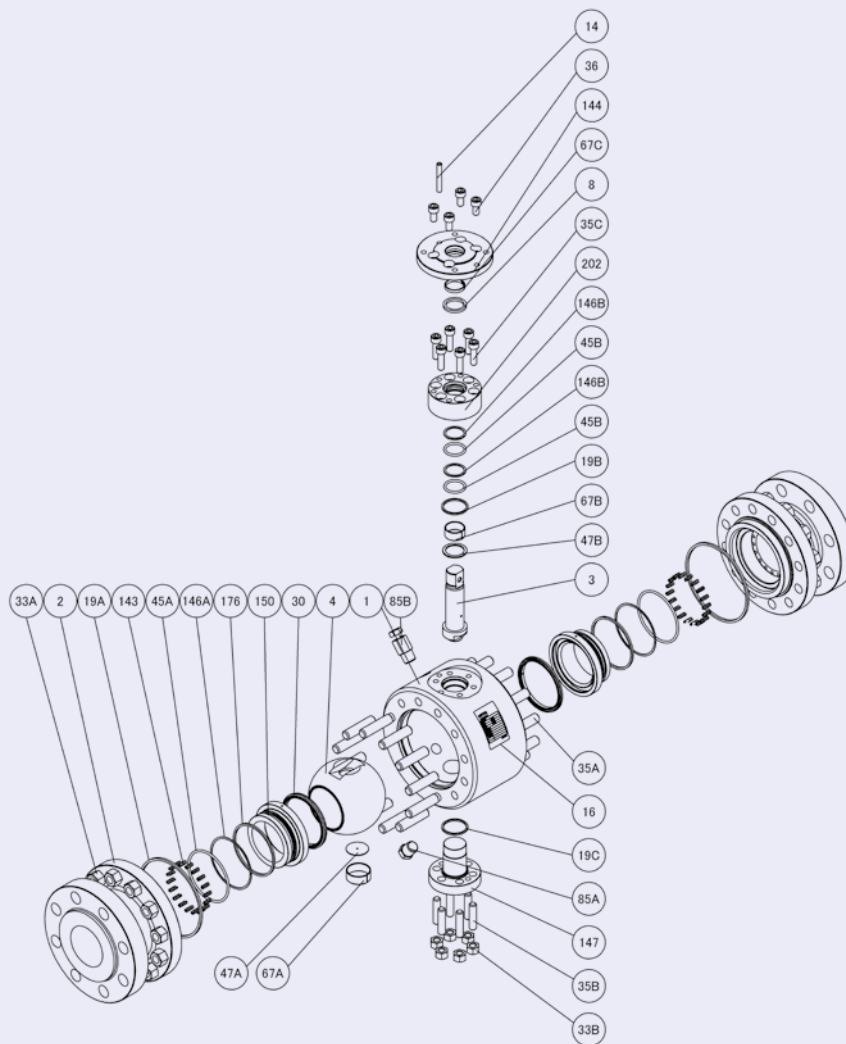

NO	NAME OF PARTS	MATERIALS	NO	NAME OF PARTS	MATERIALS
1	BODY	A105	36	GLAND BOLT	A193 Gr. B7M
2	CAP	A105	45A	O-RING	HNBR
3	STEM	A479 TYPE 316 or A276 TYPE 316 or A182 Gr. F316	45B	O-RING	HNBR
4	BALL	A105 + ENP or A216 Gr. WCB + ENP F60+ENP (CLASS 900/1500)	47A	THRUST WASHER	RPTFE
8	GLAND PACKING	FLEXIBLE GRAPHITE	47B	THRUST WASHER	CS + RPTFE
14	SET PIN	A564 TYPE 630 H1150D	67A	CURL BEARING (BALL)	CS + RPTFE
16	NAME PLATE	STAINLESS STEEL	67C	STEM BEARING	PTFE
19A	GASKET	FLEXIBLE GRAPHITE	85A	PLUG	A350 Gr. LF2 cl.1
19B	GASKET	FLEXIBLE GRAPHITE	85B	VENT VALVE	A350 Gr. LF2 cl.1
19C	GASKET	FLEXIBLE GRAPHITE	143	SEAT SPRING	INCONEL® X750 NICKEL ALLOY
30	BALL SEAT	RPTFE	144	GLAND PLATE	A105
33A	CAP NUT	A194 Gr. 2HM	146A	BACK UP RING	PTFE
33B	COVER NUT	A194 Gr. 2HM	146B	BACK UP RING	PTFE
35A	CAP BOLT	A193 Gr. B7M	147	END PLATE	A105
35B	COVER BOLT	A193 Gr. B7M	150	SEAT RETAINER	A105 + ENP
35C	BONNET BOLT	A193 Gr. B7M	176	RETAINER PACKING	BRAIDED GRAPHITE
			202	BONNET	A105

The illustration shown in this catalog represents the typical structure of Class 600 valves.

The structure may differ depending on sizes and classes. Please consult KITZ for more details on the specifications and structure of the valve.



## Construction and Materials

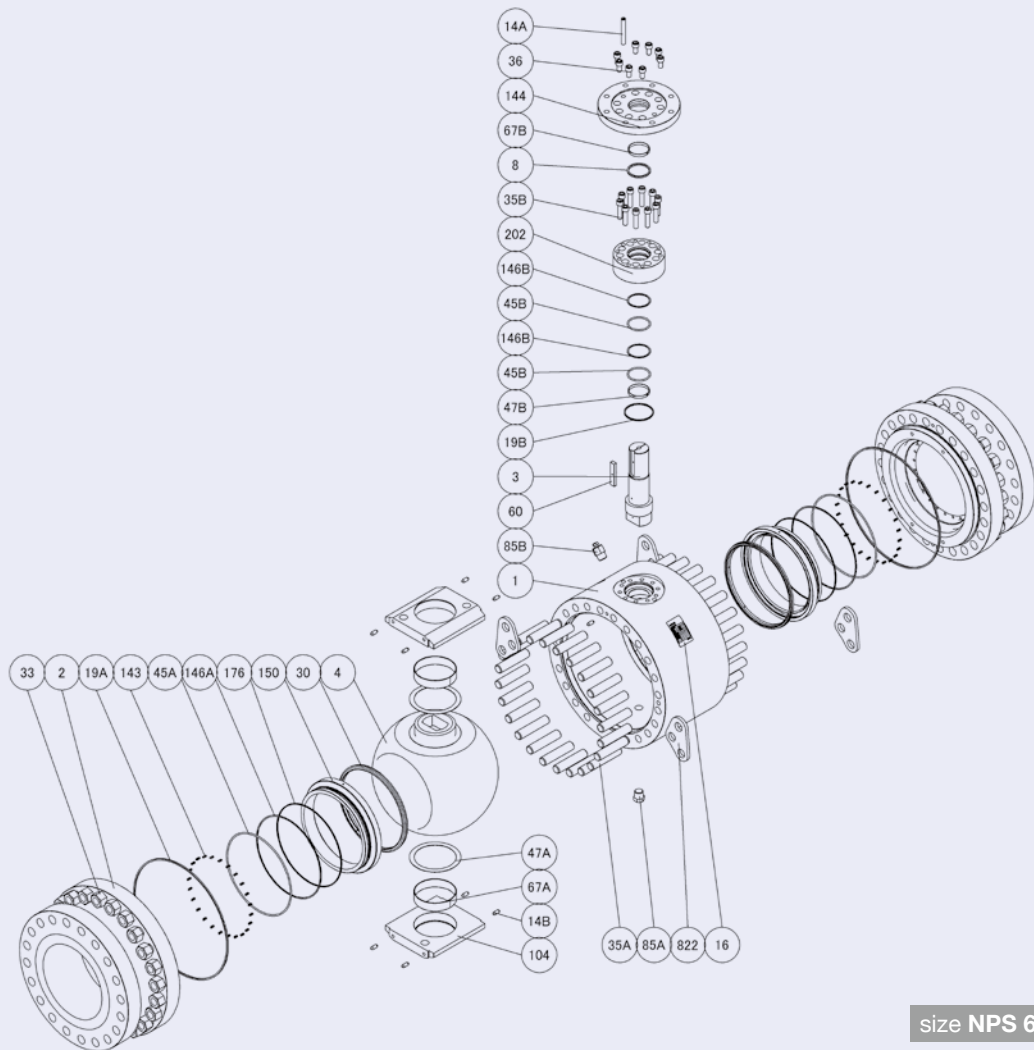

size NPS 6 and larger

NO	NAME OF PARTS	MATERIALS	NO	NAME OF PARTS	MATERIALS
1	BODY	A105	45B	O-RING	HNBR
2	CAP	A105	47A	THRUST WASHER	RPTFE
3	STEM	A479 TYPE 316 or A276 TYPE 316 or A182 Gr. F316	47B	THRUST WASHER	CS + RPTFE
4	BALL	A105 + ENP or A216 Gr. WCB + ENP F60+ENP (CLASS 900/1500)	60	KEY	CARBON STEEL
8	GLAND PACKING	FLEXIBLE GRAPHITE	67A	CURL BEARING (BALL)	CS + RPTFE
14A	SET PIN	A564 TYPE 630 H1150D	67B	STEM BEARING	PTFE
14B	SET PIN	A276 TYPE 316 or A479 TYPE 316	85A	PLUG	A350 Gr. LF2 cl.1
16	NAME PLATE	STAINLESS STEEL	85B	VENT VALVE	A350 Gr. LF2 cl.1
19A	GASKET	FLEXIBLE GRAPHITE	104	TRUNNION PLATE	A105 or A216 Gr. WCB
19B	GASKET	FLEXIBLE GRAPHITE	143	SEAT SPRING	INCONEL® X750 NICKEL ALLOY
30	BALL SEAT	RPTFE	144	GLAND PLATE	A105
33	CAP NUT	A194 Gr. 2HM	146A	BACK UP RING	PTFE
35A	CAP BOLT	A193 Gr. B7M	146B	BACK UP RING	PTFE
35B	BONNET BOLT	A193 Gr. B7M	150	SEAT RETAINER	A105 + ENP
36	GLAND BOLT	A193 Gr. B7M	176	RETAINER PACKING	BRAIDED GRAPHITE
45A	O-RING	HNBR	202	BONNET	A105
			822	LIFTING LUG	CARBON STEEL

The illustration shown in this catalog represents the typical structure of Class 600 valves.

The structure may differ depending on sizes and classes. Please consult KITZ for more details on the specifications and structure of the valve.

# Valve Dimensions and Operators

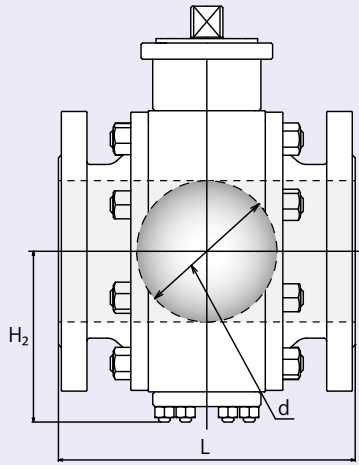

Up to Size NPS 4

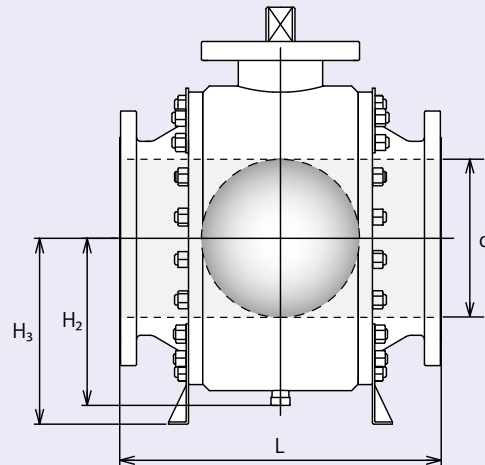

Size NPS 6 and larger

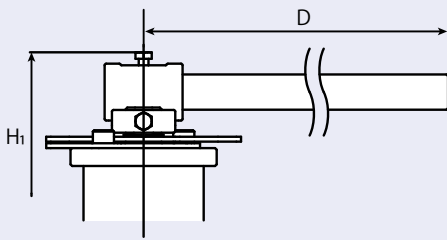

Lever

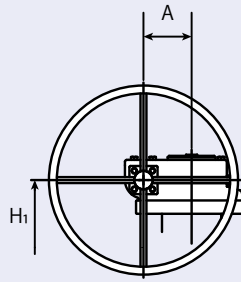

Gear

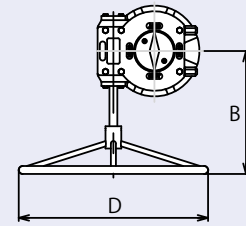

< size unit : mm >

## Class 150

Nominal Size	NPS	2	3	4	6	8	10	12	14	16	18	20	24	
	DN	50	80	100	150	200	250	300	350	400	450	500	600	
Valve Operator		Lever					Gear							
d		49	74	100	150	201	252	303	334	385	436	487	589	
L		178	203	229	394	457	533	610	686	762	864	914	1067	
H1		159	201	260	326	316	372	407	441	511	551	613	687	
H2		96	116	148	185	221	275	-	-	-	-	-	-	
H3		-	-	-	-	-	-	426	444	498	526	618	697	
A		-	-	-	-	86	105	105	53	130	130	130	130	
B		-	-	-	-	305	396	396	396	567	567	567	567	
D		300	400	450	750	500	600	600	600	800	800	800	800	

## Class 300

Nominal Size	NPS	2	3	4	6	8	10	12	14	16	18	20	24	
	DN	50	80	100	150	200	250	300	350	400	450	500	600	
Valve Operator		Lever					Gear							
d		49	74	100	150	201	252	303	334	385	436	487	589	
L		216	283	305	403	502	568	648	762	838	914	991	1143	
H1		159	201	260	326	316	372	415	441	511	551	613	695	
H2		96	116	148	185	221	275	-	-	-	-	-	-	
H3		-	-	-	-	-	-	428	445	498	528	618	698	
A		-	-	-	-	86	105	53	53	130	130	130	140	
B		-	-	-	-	305	396	396	396	567	567	567	567	
D		300	400	450	750	500	600	600	600	800	800	800	800	

# Valve Dimensions and Operators

## Class 600

unit: mm

Nominal Size	NPS	2	3	4	6	8	10	12	14	16	18	20	24
	DN	50	80	100	150	200	250	300	350	400	450	500	600
Valve Operator		Lever						Gear					
d		49	74	100	150	201	252	303	334	385	436	487	589
L		292	356	432	559	660	787	838	889	991	1092	1194	1397
H1		182	236	263	282	335	382	448	478	540	588	652	749
H2		98	120	150	191	237	-	-	-	-	-	-	-
H3		-	-	-	-	-	383	427	459	497	553	643	721
A		-	-	-	86	105	53	130	130	130	140	140	182
B		-	-	-	305	396	396	567	567	567	581	581	570
D		400	450	800	500	600	600	800	800	800	800	800	800

## Class 900

unit: mm

Nominal Size	NPS	2	3	4	6	8	10	12	14	16	18	20	24
	DN	50	80	100	150	200	250	300	350	400	450	500	600
Valve Operator		Lever						Gear					
d		49	74	100	150	201	252	303	322	373	423	471	570
L		368	381	457	610	737	838	965	1029	1130	1219	1321	1549
H1		218	243	276	295	355	406	480	547	588	673	781	930
H2		109	134	172	201	246	-	-	-	-	-	-	-
H3		-	-	-	-	-	414	454	508	570	614	676	788
A		-	-	-	86	53	130	130	140	140	182	279	279
B		-	-	-	305	396	417	567	581	581	570	701	701
D		700	700	700	600	600	600	800	800	800	800	800	800

## Class 1500

unit: mm

Nominal Size	NPS	2	3	4	6	8	10	12	14	16	18	20	24
	DN	50	80	100	150	200	250	300	350	400	450	500	600
Valve Operator		Lever						Gear					
d		49	74	100	144	192	239	287	315	360	406	454	546
L		368	470	546	705	832	991	1130	1257	1384	1537	1664	1972
H1		218	250	262	353	435	482	600	625	730	807	912	1000
H2		109	146	186	237	-	-	-	-	-	-	-	-
H3		-	-	-	-	408	446	556	568	623	701	764	857
A		-	-	86	53	130	130	182	182	279	279	279	279
B		-	-	305	396	567	567	570	570	701	701	701	701
D		700	900	500	600	600	800	800	800	800	800	800	800

< size unit : inch >

## Class 150

unit: inch

Nominal Size	NPS	2	3	4	6	8	10	12	14	16	18	20	24
	DN	50	80	100	150	200	250	300	350	400	450	500	600
Valve Operator		Lever						Gear					
d		1.94	2.94	3.94	5.94	7.94	9.94	11.94	13.19	15.19	17.19	19.19	23.19
L		7.00	8.00	9.00	15.50	18.00	21.00	24.00	27.00	30.00	34.00	36.00	42.00
H1		6.26	7.91	10.24	12.83	12.44	14.65	16.02	17.36	20.12	21.69	24.13	27.05
H2		3.78	4.57	5.83	7.28	8.70	10.83	-	-	-	-	-	-
H3		-	-	-	-	-	-	16.77	17.48	19.61	20.71	24.33	27.44
A		-	-	-	-	3.39	4.13	4.13	2.09	5.12	5.12	5.12	5.12
B		-	-	-	-	12.01	15.59	15.59	15.59	22.32	22.32	22.32	22.32
D		11.81	15.75	17.72	29.53	19.69	23.62	23.62	23.62	31.50	31.50	31.50	31.50

## Class 300

unit: inch

Nominal Size	NPS	2	3	4	6	8	10	12	14	16	18	20	24
	DN	50	80	100	150	200	250	300	350	400	450	500	600
Valve Operator		Lever						Gear					
d		1.94	2.94	3.94	5.94	7.94	9.94	11.94	13.19	15.19	17.19	19.19	23.19
L		8.50	11.13	12.00	15.88	19.75	22.38	25.50	30.00	33.00	36.00	39.00	45.00
H1		6.26	7.91	10.24	12.83	12.44	14.65	16.34	17.36	20.12	21.69	24.13	27.36
H2		3.78	4.57	5.83	7.28	8.70	10.83	-	-	-	-	-	-
H3		-	-	-	-	-	-	16.85	17.52	19.61	20.79	24.33	27.48
A		-	-	-	-	3.39	4.13	2.09	2.09	5.12	5.12	5.12	5.51
B		-	-	-	-	12.01	15.59	15.59	15.59	22.32	22.32	22.32	22.32
D		11.81	15.75	17.72	29.53	19.69	23.62	23.62	23.62	31.50	31.50	31.50	31.50

## Valve Dimensions and Operators

### Class 600

unit: inch

Nominal Size	NPS	2	3	4	6	8	10	12	14	16	18	20	24
	DN	50	80	100	150	200	250	300	350	400	450	500	600
Valve Operator		Lever				Gear							
d		1.94	2.94	3.94	5.94	7.94	9.94	11.94	13.19	15.19	17.19	19.19	23.19
L		11.50	14.00	17.00	22.00	26.00	31.00	33.00	35.00	39.00	43.00	47.00	55.00
H1		7.17	9.29	10.35	11.10	13.19	15.04	17.64	18.82	21.26	23.15	25.67	29.49
H2		3.86	4.72	5.91	7.52	9.33	-	-	-	-	-	-	-
H3		-	-	-	-	-	15.08	16.81	18.07	19.57	21.77	25.31	28.39
A		-	-	-	3.39	4.13	2.09	5.12	5.12	5.12	5.51	5.51	7.17
B		-	-	-	12.01	15.59	15.59	22.32	22.32	22.32	22.87	22.87	22.44
D		15.75	17.72	31.50	19.69	23.62	23.62	31.50	31.50	31.50	31.50	31.50	31.50

### Class 900

unit: inch

Nominal Size	NPS	2	3	4	6	8	10	12	14	16	18	20	24
	DN	50	80	100	150	200	250	300	350	400	450	500	600
Valve Operator		Lever				Gear							
d		1.94	2.94	3.94	5.94	7.94	9.94	11.94	12.69	14.69	16.69	18.56	22.44
L		14.50	15.00	18.00	24.00	29.00	33.00	38.00	40.50	44.50	48.00	52.00	61.00
H1		8.58	9.57	10.87	11.61	13.98	15.98	18.90	21.54	23.15	26.50	30.75	36.61
H2		4.29	5.28	6.77	7.91	9.69	-	-	-	-	-	-	-
H3		-	-	-	-	-	16.30	17.87	20.00	22.44	24.17	26.61	31.02
A		-	-	-	3.39	2.09	5.12	5.12	5.51	5.51	7.17	10.98	10.98
B		-	-	-	12.01	15.59	16.42	22.32	22.87	22.87	22.44	27.60	27.60
D		27.56	27.56	27.56	23.62	23.62	23.62	31.50	31.50	31.50	31.50	31.50	31.50

### Class 1500

unit: inch

Nominal Size	NPS	2	3	4	6	8	10	12	14	16	18	20	24
	DN	50	80	100	150	200	250	300	350	400	450	500	600
Valve Operator		Lever				Gear							
d		1.94	2.94	3.94	5.69	7.56	9.44	11.31	12.44	14.19	16.00	17.88	21.50
L		14.50	18.50	21.50	27.75	32.75	39.00	44.50	49.50	54.50	60.50	65.50	76.50
H1		8.58	9.84	10.31	13.90	17.13	18.98	23.62	24.61	28.74	31.77	35.91	39.37
H2		4.29	5.75	7.32	9.33	-	-	-	-	-	-	-	-
H3		-	-	-	-	16.06	17.56	21.89	22.36	24.53	27.60	30.08	33.74
A		-	-	3.39	2.09	5.12	5.12	7.17	7.17	10.98	10.98	10.98	10.98
B		-	-	12.01	15.59	22.32	22.32	22.44	22.44	27.60	27.60	27.60	27.60
D		27.56	35.43	19.69	23.62	23.62	31.50	31.50	31.50	31.50	31.50	31.50	31.50

## Material Example

Service	Non-corrosive	Low Temp.	Corrosive	Sour	
Body/Cap	A105	LF2	F316	F51, S31803 or CD3MN	F55, S32760 or CD3MWCuN
Stem	316SS	316SS	316SS	F51 or S31803	F55 or S32760
Ball	A105+ENP	LF2+ENP F60+ENP (CLASS 900/1500)	316SS F51, S31803 or CD3MN (CLASS 900/1500)	F51, S31803 or CD3MN	F55, S32760 or CD3MWCuN
Seat Retainer	A105+ENP	LF2+ENP	316SS	F51, S31803 or CD3MN	F55, S32760 or CD3MWCuN
Ball Seat	CLASS 150 to 600: RPTFE CLASS 900 and over: RNYLON				
Spring	INCONEL® X750				
O-ring	HNBR	L-NBR	FKM	FKM	FKM
Bolt	B7M	L7M	B8M	B8M	B8M
Nut	2HM	7M	8M	8M	8M

## Dimensions of Actuator Mounting Pads

KITZ trunnion mounted ball valves are provided with integral actuator mounting pads designed in compliance with ISO 5211. This feature enables users to readily mount actuators on these valves.

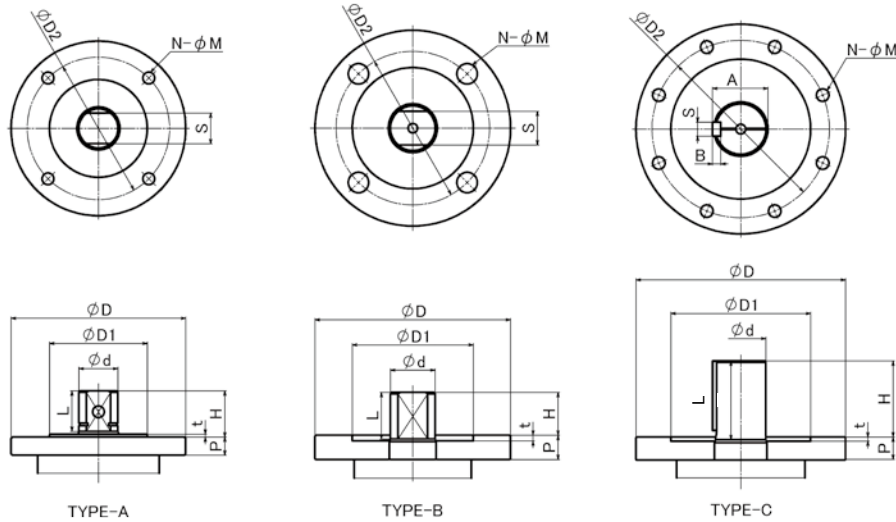

< size unit : mm >

### T60S Class 150

Nominal Size	NPS DN	unit: mm											
		2 50	3 80	4 100	6 150	8 200	10 250	12 300	14 350	16 400	18 450	20 500	24 600
TYPE		A	A	A	A	B	B	B	C	C	C	C	C
$\phi d$		18	22	28	48	48	60	60	60	72	72	80	80
$\phi D$		65	90	125	175	210	300	300	300	300	300	300	300
$\phi D1$		35	55	70	100	130	200	200	200	200	200	200	200
$\phi D2$		50	70	102	140	165	254	254	254	254	254	254	254
t		3	3	3	3	6	6	6	6	6	6	6	6
L		19	21	26	44.5	54	64	64	89	113	113	112	112
H		23	25	30	49.5	50	60	60	85	109	109	109	109
S		14	17	22	36	36	46	46	18	20	20	22	22
A		-	-	-	-	-	-	-	64	76.5	76.5	85	85
B		-	-	-	-	-	-	-	11	12	12	14	14
N		4	4	4	4	4	8	8	8	8	8	8	8
M		M6	M8	M10	M16	22	18	18	18	18	18	18	18
P		9	11	13	17	26	28	28	28	33	33	38	38
ISO 5211 Flange Type		F05	F07	F10	F14	F16	F25	F25	F25	F25	F25	F25	F25

### T60S Class 300

Nominal Size	NPS DN	unit: mm											
		2 50	3 80	4 100	6 150	8 200	10 250	12 300	14 350	16 400	18 450	20 500	24 600
TYPE		A	A	A	A	B	B	B	C	C	C	C	C
$\phi d$		18	22	28	48	48	60	60	60	72	72	80	80
$\phi D$		65	90	125	175	210	300	300	300	300	300	300	350
$\phi D1$		35	55	70	100	130	200	200	200	200	200	200	230
$\phi D2$		50	70	102	140	165	254	254	254	254	254	254	298
t		3	3	3	3	6	6	6	6	6	6	6	6
L		19	21	26	44.5	54	64	64	89	113	113	112	112
H		23	25	30	49.5	50	60	60	85	109	109	109	109
S		14	17	22	36	36	46	46	18	20	20	22	22
A		-	-	-	-	-	-	-	64	76.5	76.5	85	85
B		-	-	-	-	-	-	-	11	12	12	14	14
N		4	4	4	4	4	8	8	8	8	8	8	8
M		M6	M8	M10	M16	22	18	18	18	18	18	18	18
P		9	11	13	17	26	28	28	28	33	33	38	38
ISO 5211 Flange Type		F05	F07	F10	F14	F16	F25	F25	F25	F25	F25	F25	F30

### T60S Class 600

unit: mm

Nominal Size	NPS	2	3	4	6	8	10	12	14	16	18	20	24
	DN	50	80	100	150	200	250	300	350	400	450	500	600
TYPE		A	A	A	B	B	C	C	C	C	C	C	C
$\phi$ d		22	28	36	48	60	60	72	72	80	80	98	98
$\phi$ D		90	125	150	210	300	300	300	300	300	350	350	415
$\phi$ D1		55	70	85	130	200	200	200	200	200	230	230	260
$\phi$ D2		70	102	125	165	254	254	254	254	254	298	298	356
t		3	3	3	6	6	6	6	6	6	6	6	6
L		21	26	33	50	64	89	113	113	112	112	131	131
H		25	30	37	46	60	85	109	109	109	109	128	128
S		17	22	27	36	46	18	20	20	22	22	28	28
A		-	-	-	-	-	64	76.5	76.5	85	85	104	104
B		-	-	-	-	-	11	12	12	14	14	16	16
N		4	4	4	4	8	8	8	8	8	8	8	8
M		M8	M10	M12	22	18	18	18	18	18	22	22	32
P		11	13	13	26	28	28	33	33	38	38	41	41
ISO 5211 Flange Type		F07	F10	F12	F16	F25	F25	F25	F25	F25	F30	F30	F35

### T60S Class 900

unit: mm

Nominal Size	NPS	2	3	4	6	8	10	12	14	16	18	20	24
	DN	50	80	100	150	200	250	300	350	400	450	500	600
TYPE		A	A	A	B	B	C	C	C	C	C	C	C
$\phi$ d		28	28	36	48	60	60	72	98	98	98	120	160
$\phi$ D		125	125	150	210	300	300	300	350	350	415	475	560
$\phi$ D1		70	70	85	130	200	200	200	230	230	260	300	370
$\phi$ D2		102	102	125	165	254	254	254	298	298	356	406	483
t		3	3	3	6	6	6	6	6	6	6	9	9
L		26	26	33	50	64	89	113	132.5	132.5	140	168	172
H		30	30	37	46	60	85	109	130.5	130.5	138	165	168
S		22	22	27	36	46	18	20	28	28	28	32	40
A		-	-	-	-	-	64	76.5	104	104	104	127	169
B		-	-	-	-	-	11	12	16	16	16	18	22
N		4	4	4	4	8	8	8	8	8	8	8	12
M		M10	M10	M12	22	18	18	18	22	22	32	38	38
P		13	13	13	26	28	28	33	42	42	52	62	73
ISO 5211 Flange Type		F10	F10	F12	F16	F25	F25	F25	F30	F30	F35	F40	F48

### T60S Class 1500

unit: mm

Nominal Size	NPS	2	3	4	6	8	10	12	14	16	18	20	24
	DN	50	80	100	150	200	250	300	350	400	450	500	600
TYPE		A	A	B	B	C	C	C	C	C	C	C	C
$\phi$ d		28	36	48	60	72	80	98	98	120	120	160	160
$\phi$ D		125	150	210	300	300	300	415	415	475	475	560	560
$\phi$ D1		70	85	130	200	200	200	260	260	300	300	370	370
$\phi$ D2		102	125	165	254	254	254	356	356	406	406	483	483
t		3	3	6	6	6	6	6	6	9	9	9	9
L		26	33	50	64	113	112	131	140	168	168	172	172
H		30	37	46	60	109	109	128	138	165	165	168	168
S		22	27	36	46	20	22	28	28	32	32	40	40
A		-	-	-	-	77	85	104	104	127	127	169	169
B		-	-	-	-	12	14	16	16	18	18	22	22
N		4	4	4	8	8	8	8	8	8	8	12	12
M		M10	M12	22	18	18	18	32	32	38	38	38	38
P		13	13	26	33	33	41	41	52	62	62	73	73
ISO 5211 Flange Type		F10	F12	F16	F25	F25	F25	F35	F35	F40	F40	F48	F48

< size unit : inch >

### T60S Class 150

unit: inch

Nominal Size	NPS	2	3	4	6	8	10	12	14	16	18	20	24
	DN	50	80	100	150	200	250	300	350	400	450	500	600
TYPE		A	A	A	A	B	B	B	C	C	C	C	C
$\phi$ d		0.71	0.87	1.10	1.89	1.89	2.36	2.36	2.36	2.83	2.83	3.15	3.15
$\phi$ D		2.56	3.54	4.92	6.89	8.27	11.81	11.81	11.81	11.81	11.81	11.81	11.81
$\phi$ D1		1.38	2.17	2.76	3.94	5.12	7.87	7.87	7.87	7.87	7.87	7.87	7.87
$\phi$ D2		1.97	2.76	4.02	5.51	6.50	10.00	10.00	10.00	10.00	10.00	10.00	10.00
t		0.12	0.12	0.12	0.12	0.24	0.24	0.24	0.24	0.24	0.24	0.24	0.24
L		0.75	0.83	1.02	1.75	2.13	2.52	2.52	3.50	4.45	4.45	4.41	4.41
H		0.91	0.98	1.18	1.95	1.97	2.36	2.36	3.35	4.29	4.29	4.29	4.29
S		0.55	0.67	0.87	1.42	1.42	1.81	1.81	0.71	0.79	0.79	0.87	0.87
A		-	-	-	-	-	-	-	2.52	3.01	3.01	3.35	3.35
B		-	-	-	-	-	-	-	0.43	0.47	0.47	0.55	0.55
N		4	4	4	4	4	8	8	8	8	8	8	8
M		M6	M8	M10	M16	0.87	0.71	0.71	0.71	0.71	0.71	0.71	0.71
P		0.35	0.43	0.51	0.67	1.02	1.10	1.10	1.10	1.30	1.30	1.50	1.50
ISO 5211 Flange Type		F05	F07	F10	F14	F16	F25	F25	F25	F25	F25	F25	F25

### T60S Class 300

unit: inch

Nominal Size	NPS	2	3	4	6	8	10	12	14	16	18	20	24
	DN	50	80	100	150	200	250	300	350	400	450	500	600
TYPE		A	A	A	A	B	B	B	C	C	C	C	C
φ d		0.71	0.87	1.10	1.89	1.89	2.36	2.36	2.36	2.83	2.83	3.15	3.15
φ D		2.56	3.54	4.92	6.89	8.27	11.81	11.81	11.81	11.81	11.81	11.81	13.78
φ D1		1.38	2.17	2.76	3.94	5.12	7.87	7.87	7.87	7.87	7.87	7.87	9.06
φ D2		1.97	2.76	4.02	5.51	6.50	10.00	10.00	10.00	10.00	10.00	10.00	11.73
t		0.12	0.12	0.12	0.12	0.24	0.24	0.24	0.24	0.24	0.24	0.24	0.24
L		0.75	0.83	1.02	1.75	2.13	2.52	2.52	3.50	4.45	4.45	4.41	4.41
H		0.91	0.98	1.18	1.95	1.97	2.36	2.36	3.35	4.29	4.29	4.29	4.29
S		0.55	0.67	0.87	1.42	1.42	1.81	1.81	0.71	0.79	0.79	0.87	0.87
A		-	-	-	-	-	-	-	2.52	3.01	3.01	3.35	3.35
B		-	-	-	-	-	-	-	0.43	0.47	0.47	0.55	0.55
N		4	4	4	4	4	8	8	8	8	8	8	8
M		M6	M8	M10	M16	0.87	0.71	0.71	0.71	0.71	0.71	0.71	0.71
P		0.35	0.43	0.51	0.67	1.02	1.10	1.10	1.10	1.30	1.30	1.50	1.50
ISO 5211 Flange Type		F05	F07	F10	F14	F16	F25	F25	F25	F25	F25	F25	F30

### T60S Class 600

unit: inch

Nominal Size	NPS	2	3	4	6	8	10	12	14	16	18	20	24
	DN	50	80	100	150	200	250	300	350	400	450	500	600
TYPE		A	A	A	B	B	C	C	C	C	C	C	C
φ d		0.87	1.10	1.42	1.89	2.36	2.36	2.83	2.83	3.15	3.15	3.86	3.86
φ D		3.54	4.92	5.91	8.27	11.81	11.81	11.81	11.81	11.81	13.78	13.78	16.34
φ D1		2.17	2.76	3.35	5.12	7.87	7.87	7.87	7.87	7.87	9.06	9.06	10.24
φ D2		2.76	4.02	4.92	6.50	10.00	10.00	10.00	10.00	10.00	11.73	11.73	14.02
t		0.12	0.12	0.12	0.24	0.24	0.24	0.24	0.24	0.24	0.24	0.24	0.24
L		0.83	1.02	1.30	1.97	2.52	3.50	4.45	4.45	4.41	4.41	5.16	5.16
H		0.98	1.18	1.46	1.81	2.36	3.35	4.29	4.29	4.29	4.29	5.04	5.04
S		0.67	0.87	1.06	1.42	1.81	0.71	0.79	0.79	0.87	0.87	1.10	1.10
A		-	-	-	-	-	2.52	3.01	3.01	3.35	3.35	4.09	4.09
B		-	-	-	-	-	0.43	0.47	0.47	0.55	0.55	0.63	0.63
N		4	4	4	4	8	8	8	8	8	8	8	8
M		M8	M10	M12	0.87	0.71	0.71	0.71	0.71	0.71	0.87	0.87	1.26
P		0.43	0.51	0.51	1.02	1.10	1.10	1.30	1.30	1.50	1.50	1.61	1.61
ISO 5211 Flange Type		F07	F10	F12	F16	F25	F25	F25	F25	F25	F30	F30	F35

### T60S Class 900

unit: inch

Nominal Size	NPS	2	3	4	6	8	10	12	14	16	18	20	24
	DN	50	80	100	150	200	250	300	350	400	450	500	600
TYPE		A	A	A	B	B	C	C	C	C	C	C	C
φ d		1.10	1.10	1.42	1.89	2.36	2.36	2.83	3.86	3.86	3.86	4.72	6.30
φ D		4.92	4.92	5.91	8.27	11.81	11.81	11.81	13.78	13.78	16.34	18.70	22.05
φ D1		2.76	2.76	3.35	5.12	7.87	7.87	7.87	9.06	9.06	10.24	11.81	14.57
φ D2		4.02	4.02	4.92	6.50	10.00	10.00	10.00	11.73	11.73	14.02	15.98	19.02
t		0.12	0.12	0.12	0.24	0.24	0.24	0.24	0.24	0.24	0.24	0.35	0.35
L		1.02	1.02	1.30	1.97	2.52	3.50	4.45	5.22	5.22	5.51	6.61	6.77
H		1.18	1.18	1.46	1.81	2.36	3.35	4.29	5.14	5.14	5.43	6.50	6.61
S		0.87	0.87	1.06	1.42	1.81	0.71	0.79	1.10	1.10	1.10	1.26	1.57
A		-	-	-	-	-	2.52	3.01	4.09	4.09	4.09	5.00	6.65
B		-	-	-	-	-	0.43	0.47	0.63	0.63	0.63	0.71	0.87
N		4	4	4	4	8	8	8	8	8	8	8	12
M		M10	M10	M12	0.87	0.71	0.71	0.71	0.87	0.87	1.26	1.50	1.50
P		0.51	0.51	0.51	1.02	1.10	1.10	1.30	1.65	1.65	2.05	2.44	2.87
ISO 5211 Flange Type		F10	F10	F12	F16	F25	F25	F25	F30	F30	F35	F40	F48

### T60S Class 1500

unit: inch

Nominal Size	NPS	2	3	4	6	8	10	12	14	16	18	20	24
	DN	50	80	100	150	200	250	300	350	400	450	500	600
TYPE		A	A	B	B	C	C	C	C	C	C	C	C
φ d		1.10	1.42	1.89	2.36	2.83	3.15	3.86	3.86	4.72	4.72	6.30	6.30
φ D		4.92	5.91	8.27	11.81	11.81	11.81	16.34	16.34	18.70	18.70	22.05	22.05
φ D1		2.76	3.35	5.12	7.87	7.87	7.87	10.24	10.24	11.81	11.81	14.57	14.57
φ D2		4.02	4.92	6.50	10.00	10.00	10.00	14.02	14.02	15.98	15.98	19.02	19.02
t		0.12	0.12	0.24	0.24	0.24	0.24	0.24	0.24	0.35	0.35	0.35	0.35
L		1.02	1.30	1.97	2.52	4.45	4.41	5.16	5.51	6.61	6.61	6.77	6.77
H		1.18	1.46	1.81	2.36	4.29	4.29	5.04	5.43	6.50	6.50	6.61	6.61
S		0.87	1.06	1.42	1.81	0.79	0.87	1.10	1.10	1.26	1.26	1.57	1.57
A		-	-	-	-	3.03	3.35	4.09	4.09	5.00	5.00	6.65	6.65
B		-	-	-	-	0.47	0.55	0.63	0.63	0.71	0.71	0.87	0.87
N		4	4	4	8	8	8	8	8	8	8	12	12
M		M10	M12	0.87	0.71	0.71	0.71	1.26	1.26	1.50	1.50	1.50	1.50
P		0.51	0.51	1.02	1.30	1.30	1.61	1.61	2.05	2.44	2.44	2.87	2.87
ISO 5211 Flange Type		F10	F12	F16	F25	F25	F25	F35	F35	F40	F40	F48	F48

## T60M Series

### Metal Seated 3-Piece Body Trunnion Mounted Ball Valves



#### GENERAL DESIGN STANDARD

- Design: API 6D/ISO 14313 (Except CL 600-24)
- Face to face: API 6D/ASME B16.10
- End connection: ASME B16.5
- Bore diameter: API 6D/ISO 14313
- Wall thickness: ASME PBVC Section VIII

#### CERTIFICATION

- Fugitive emission: ISO 15848-1 BH CO1
- Fire test: API 6FA
- PED: 2014/68/EU
- ATEX: 2014/34/EU
- SIL: IEC 61508 (SIL 2)

#### PRODUCT RANGE

- Nominal pressure: Class 150 to 600
- Nominal size: NPS 2 to 24 (DN 50 to 600)
- Shell materials:
  - Carbon steel, Alloy steel,
  - Austenitic stainless steel, Duplex stainless steel,
  - High alloy steel, Nickel based alloy
- Seat materials:
  - 316SS + Ni- Cr alloy thermal spraying

#### DESIGN FEATURE

- Structure: 3-piece bolted body and cap
- Standard material: NACE MR0175, ASTM and others
- High performance sealing mechanism
- Low operating torque
- Packing with live loaded sealing mechanism
- Double Block and Bleed function
- Self-relief of excessive cavity pressure
- Fire safe design
- Blowout-proof ball seat & stem construction
- Antistatic provision design
- Locking device for lever operation
- ISO 5211 actuator mounting pad



## Component Drawing

### Up to Size NPS 4

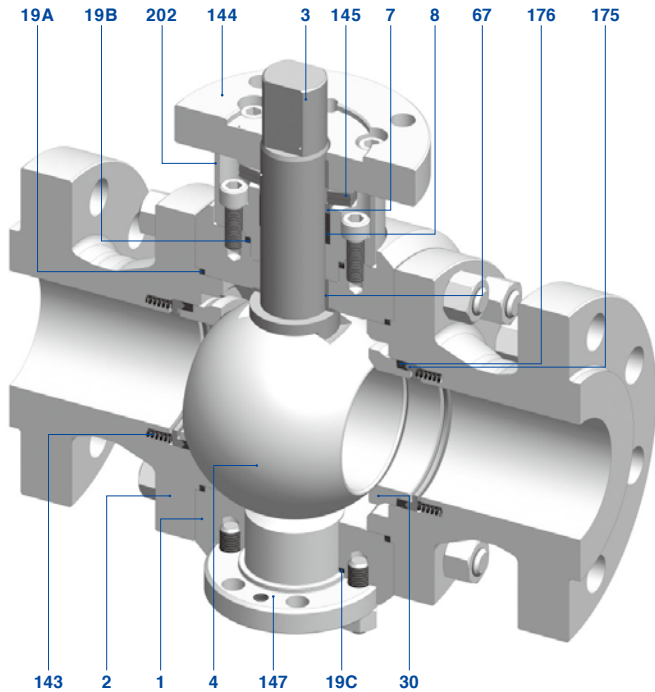

- 1 Body\*
- 2 Cap\*
- 3 Stem
- 4 Precision machined ball
- 7 Gland
- 8 Gland packing (Flexible graphite)
- 19A Gasket (Flexible graphite)
- 19B Gasket (Flexible graphite)
- 19C Gasket (Flexible graphite)
- 30 Ball seat
- 67 Stem bearing
- 143 Seat spring
- 144 Gland plate
- 145 Coned disc spring
- 147 End plate
- 175 Retainer gland
- 176 Seat packing (Flexible graphite)
- 202 Bonnet

\*Note: Made of forged carbon steel, low alloy steel and high alloy steel. Made of forged or cast austenitic stainless steel, duplex stainless steel and other special alloy materials. Contact KITZ for current available materials.

### Size NPS 6 and larger

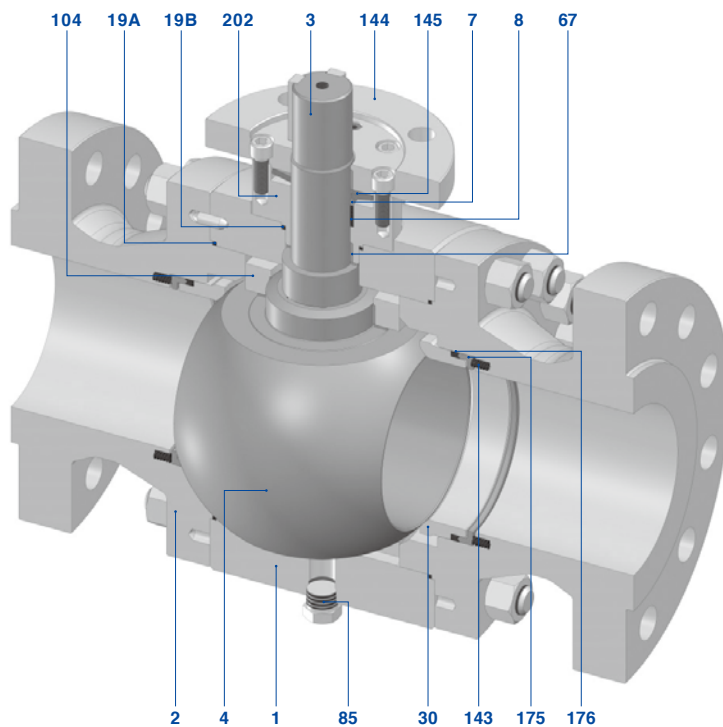

- 1 Body\*
- 2 Cap\*
- 3 Stem
- 4 Precision machined ball
- 7 Gland
- 8 Gland packing (Flexible graphite)
- 19A Gasket (Flexible graphite)
- 19B Gasket (Flexible graphite)
- 30 Ball seat
- 67 Stem bearing
- 85 Plug
- 104 Trunnion plate
- 143 Seat spring
- 144 Gland plate
- 145 Coned disc spring
- 175 Retainer gland
- 176 Seat packing (Flexible graphite)
- 202 Bonnet

The illustration shown in this catalog represents the typical structure of Class 600 valves.

The structure may differ depending on sizes and classes. Please consult KITZ for more details on the specifications and structure of the valve.

# Design Features

## 1. High Performance Sealing Mechanism

The metal seat design, as the resilient seat design does, adequately maintains each of the upstream and downstream ball seats in contact with the ball by means of repulsing force of seat springs inserted behind seat retainers. Line fluid pressure also helps this contact method. This sealing mechanism features unfailing thru-the-bore sealing performance of upstream and downstream side ball seats at the same time. And surfaces of the ball and ball seats in contact are thermally sprayed with high alloy material. This provides higher wear resistance and durability for high temperature and abrasive services.

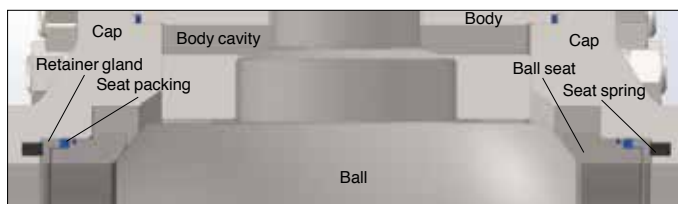

## 2. Double Block and Bleed Function

Ball seats independently shut off the line fluid on the upstream and downstream side of the ball. The valve bore and the body cavity are isolated from each other when the valve is fully open or closed. Under this condition, the cavity pressure can be discharged with a vent valve and a drain plug. The vent valve is equipped with a blowout-proof bleeder for safe discharge.

Relieving the cavity pressure with a vent valve is recommended for safe draining.

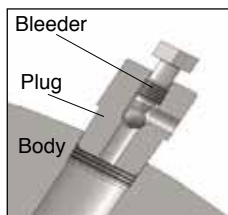

## 3. High Performance Seat Packing

The unique graphite seat packing rings with retainer glands provides reliable shut-off sealing performance during the entire service life.

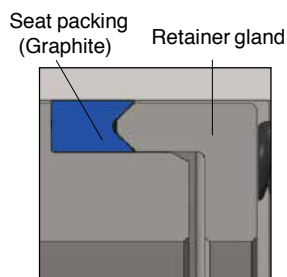

## 4. Live Loaded Packing Structure

The gland packing ring is compressed with a coned disc springs to prevent stress relaxation. This live loaded packing system provides highly durable sealing performance with no need of packing retightening.

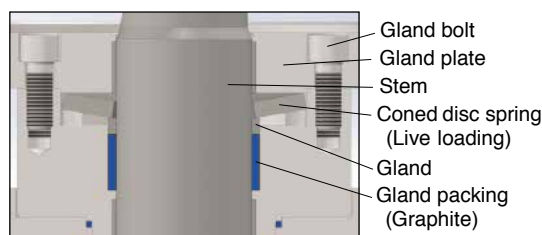

## 5. Cavity Pressure Relief

In case of incidental rise of servicing or ambient temperature, liquefied gas or highly volatile liquid trapped within the body cavity may vaporize, and cause an excessive rise in the cavity pressure. For safety consideration, when the cavity pressure exceeds the line pressure, either one of the ball seats will move slightly away from the ball surface together with seat retainers to relieve the excessive cavity pressure into the valve bore.

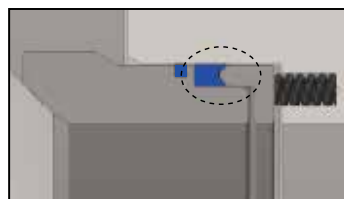

## 6. Low Emission Guaranteed Design

The fugitive emission suppressing design for both resilient and metal seated valves are certified to ISO 15848 tightness class "B" (Lower than  $10^{-4}$  mg·s<sup>-1</sup>·m<sup>-1</sup> for stem leakage and lower than 50 ppmv for body leakage). This verifies the outstanding low emission performance of the whole sealing mechanism of the valve.

## 7. Options\*

- (1) Special Shell and Trim Materials
- (2) Special Sealing Component Materials
- (3) Butt-weld Piping Connection
- (4) Pipe Pups Welded on Valve Ends
- (5) Stem Extension
- (6) Overlay for Bore and Cavity
- (7) Actuation (Pneumatic and Electric)

\*For all optional provisions, please contact your local KITZ agents or distributors

## Construction and Materials

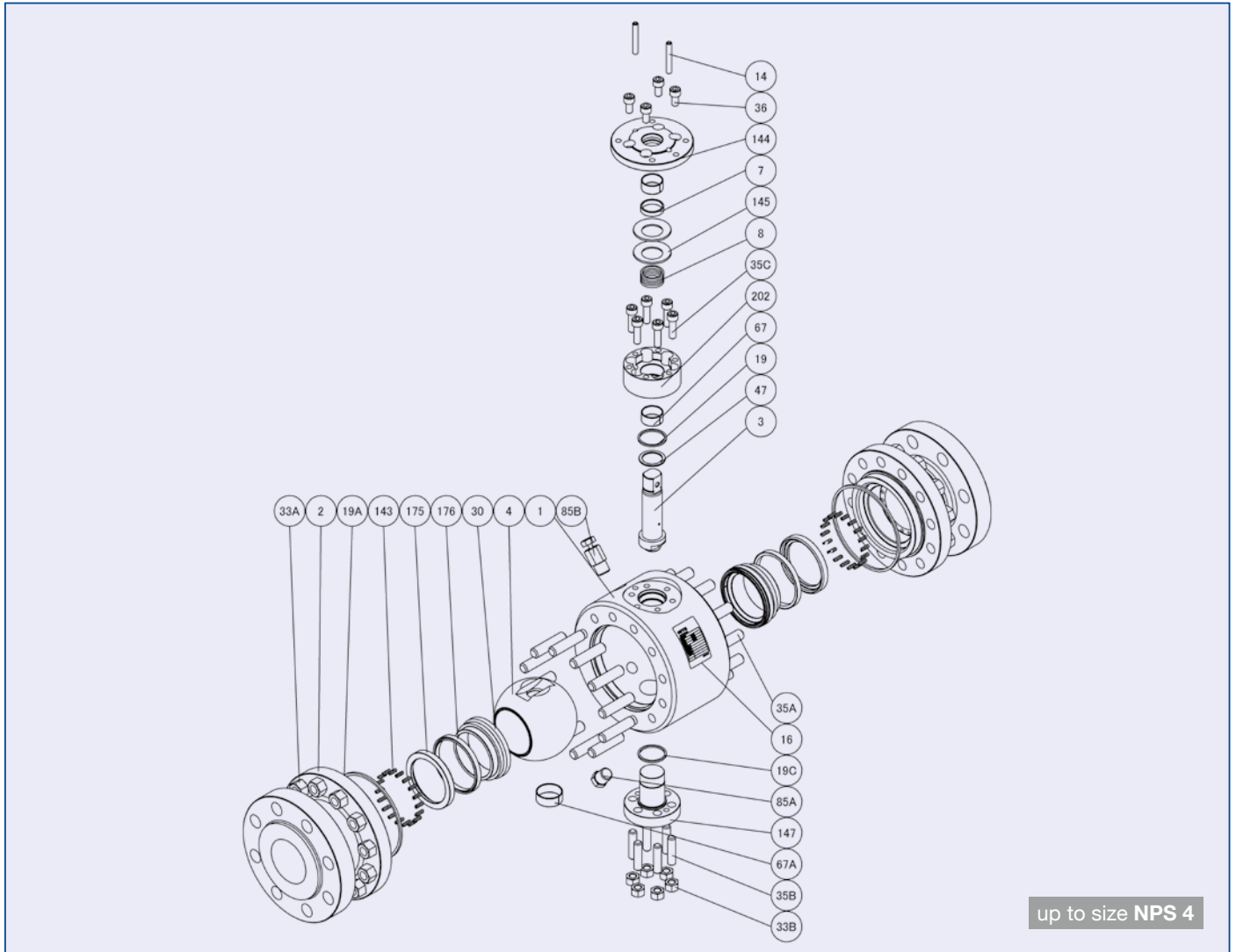

NO	NAME OF PARTS	MATERIALS	NO	NAME OF PARTS	MATERIALS
1	BODY	A105	33B	COVER NUT	A194 Gr. 2HM
2	CAP	A105	35A	CAP BOLT	A193 Gr. B7M
3	STEM	A564 TYPE 630 H1150D	35B	COVER BOLT	A193 Gr. B7M
4	BALL	A182 Gr. F316 + SFNi or A479 TYPE 316 + SFNi or A276 TYPE 316 + SFNi	35C	BONNET BOLT	A193 Gr. B7M
			36	GLAND BOLT	A193 Gr. B7M
7	GLAND	A182 Gr. F316 or A479 TYPE 316 or A276 TYPE 316	47	THRUST WASHER	HT-625 <sup>®</sup> NICKEL ALLOY + COATING
			67A	CURL BEARING (BALL)	HT-625 <sup>®</sup> NICKEL ALLOY + COATING
8	GLAND PACKING	FLEXIBLE GRAPHITE	67B	STEM BEARING	HT-625 <sup>®</sup> NICKEL ALLOY + COATING
14	SET PIN	A564 TYPE 630 H1150D	85A	PLUG	A350 Gr. LF2 cl.1
16	NAME PLATE	STAINLESS STEEL	85B	VENT VALVE	A350 Gr. LF2 cl.1
19A	GASKET	FLEXIBLE GRAPHITE	143	SEAT SPRING	INCONEL <sup>®</sup> X750 NICKEL ALLOY
19B	GASKET	FLEXIBLE GRAPHITE	144	GLAND PLATE	ASTM A105
19C	GASKET	FLEXIBLE GRAPHITE	145	CONED DISC SPRING	UNS N07718
30	BALL SEAT	A182 Gr. F316 + SFNi or A479 TYPE 316 + SFNi or A276 TYPE 316 + SFNi	147	END PLATE	A105
			175	RETAINER GLAND	A182 Gr. F316 or A479 TYPE 316 or A276 TYPE 316 or A240 TYPE 316
33A	CAP NUT	A194 Gr. 2HM	176	SEAT PACKING	FLEXIBLE GRAPHITE
			202	BONNET	A105

## Construction and Materials

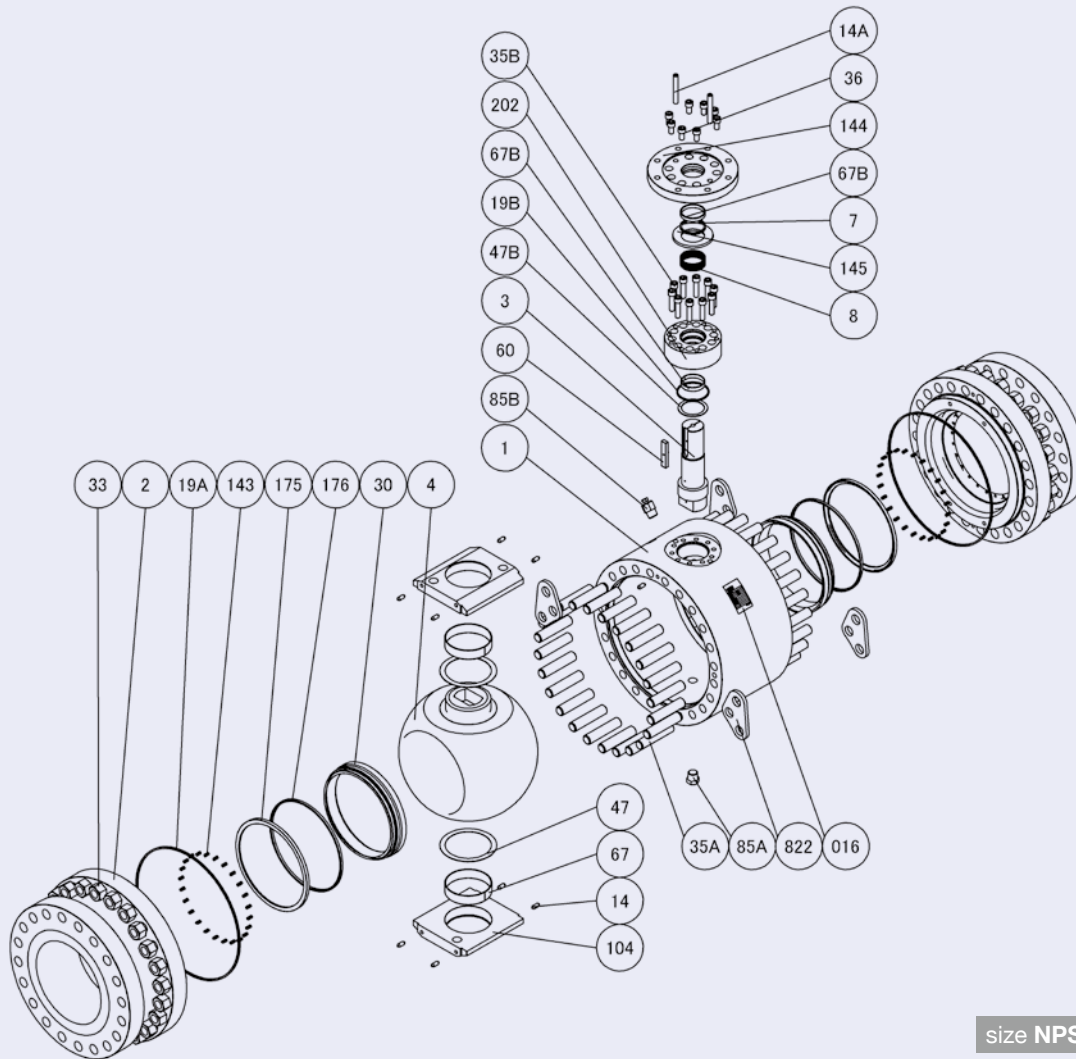

size NPS 6 and larger

NO	NAME OF PARTS	MATERIALS	NO	NAME OF PARTS	MATERIALS
1	BODY	A105	35B	BONNET BOLT	A193 Gr. B7M
2	CAP	A105	36	GLAND BOLT	A193 Gr. B7M
3	STEM	A564 TYPE 630 H1150D	47A	THRUST WASHER	HT-625 <sup>®</sup> NICKEL ALLOY + COATING
4	BALL	A182 Gr. F316 + SFNi or A479 TYPE 316 + SFNi or A276 TYPE 316 + SFNi	47B	THRUST WASHER	HT-625 <sup>®</sup> NICKEL ALLOY + COATING
			60	KEY	CARBON STEEL
			67A	CURL BEARING (BALL)	HT-625 <sup>®</sup> NICKEL ALLOY + COATING
7	GLAND	A182 Gr. F316 or A479 TYPE 316 or A276 TYPE 316	67B	STEM BEARING	HT-625 <sup>®</sup> NICKEL ALLOY + COATING
8	GLAND PACKING	FLEXIBLE GRAPHITE	85A	PLUG	A350 Gr. LF2 cl.1
14A	SET PIN	A564 TYPE 630 H1150D	85B	VENT VALVE	A350 Gr. LF2 cl.1
14B	SET PIN	A276 TYPE 316 OR A479 TYPE 316	104	TRUNNION PLATE	A105 OR A216 Gr. WCB
16	NAME PLATE	STAINLESS STEEL	143	SEAT SPRING	INCONEL <sup>®</sup> X750 NICKEL ALLOY
19A	GASKET	FLEXIBLE GRAPHITE	144	GLAND PLATE	A105
19B	GASKET	FLEXIBLE GRAPHITE	145	CONED DISC SPRING	UNS N07718
30	BALL SEAT	A182 Gr. F316 + SFNi or A479 TYPE 316 + SFNi or A276 TYPE 316 + SFNi	175	RETAINER GLAND	A182 Gr. F316 or A479 TYPE 316 or A276 TYPE 316 or A240 TYPE 316
			176	SEAT PACKING	FLEXIBLE GRAPHITE
			202	BONNET	A105
33	CAP NUT	A194 Gr. 2HM	822	LIFTING LUG	CARBON STEEL
35A	CAP BOLT	A193 Gr. B7M			

# Valve Dimensions and Operators

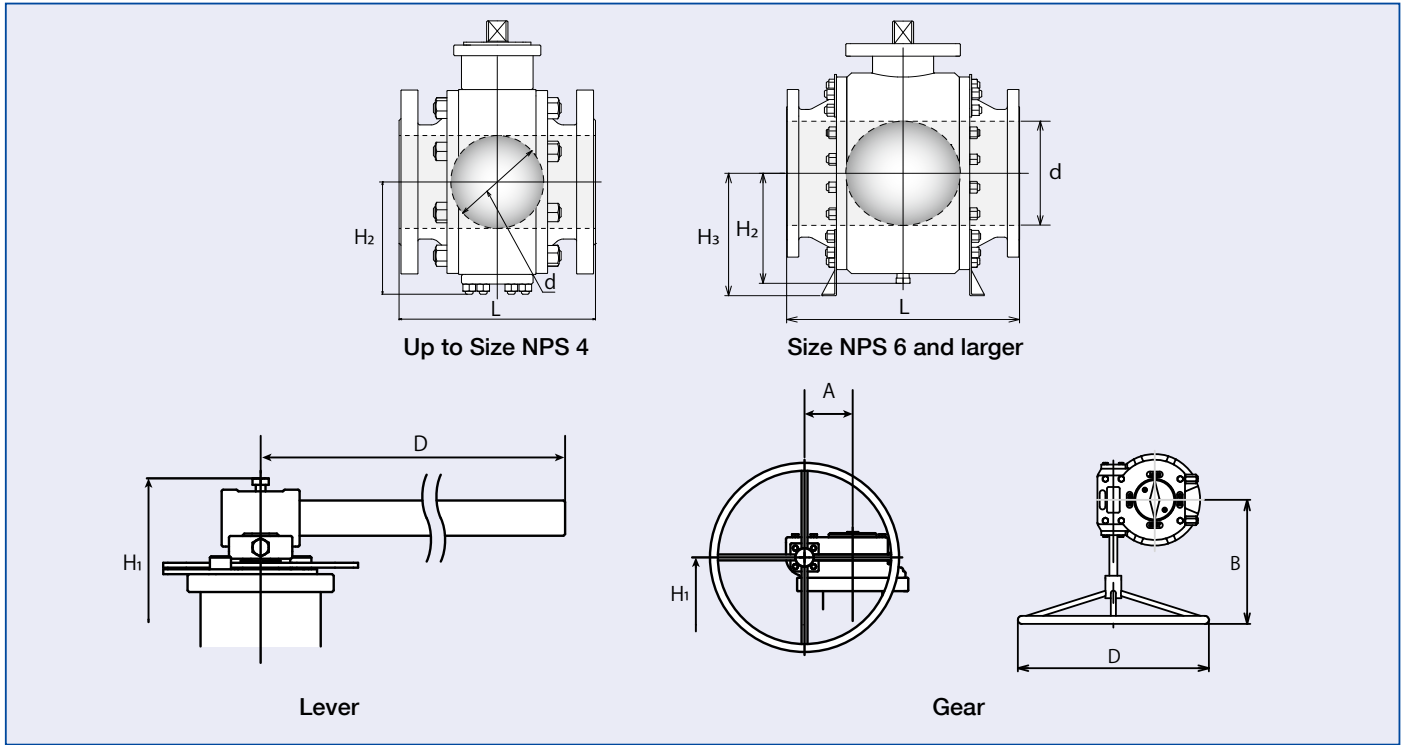

< size unit : mm >

## Class 150

Nominal Size	NPS	2	3	4	6	8	10	12	14	16	18	20	24
	DN	50	80	100	150	200	250	300	350	400	450	500	600
Valve Operator	Lever	Gear											
Ball Bore	49	74	100	150	201	252	303	334	385	436	487	589	
L	178	203	229	394	457	533	610	686	762	864	914	1067	
H1	182	188	234	283	349	398	463	483	582	612	724	807	
H2	100	123	151	191	237	284	-	-	-	-	-	-	
H3	-	-	-	-	-	-	427	445	499	526	619	698	
A	-	52	71	86	53	130	130	130	182	182	67	67	
B	-	217	282	305	396	567	567	567	570	570	600	600	
D	300	200	300	500	500	600	600	600	800	800	800	800	
Weight (kg)	25	45	80	190	350	550	840	1030	1650	1970	2940	4310	

unit: mm

## Class 300

Nominal Size	NPS	2	3	4	6	8	10	12	14	16	18	20	24
	DN	50	80	100	150	200	250	300	350	400	450	500	600
Valve Operator	Lever	Gear											
Ball Bore	49	74	100	150	201	252	303	334	385	436	487	589	
L	216	283	305	403	502	568	648	762	838	914	991	1143	
H1	182	188	242	297	348	398	472	492	582	617	724	808	
H2	100	123	151	191	237	284	-	-	-	-	-	-	
H3	-	-	-	-	-	-	429	445	498	529	618	699	
A	-	52	105	53	130	130	140	140	182	209	67	279	
B	-	217	311	348	418	567	580	580	570	491	600	701	
D	400	200	300	500	500	600	600	800	800	800	800	800	
Weight (kg)	30	55	110	225	390	590	860	1110	1760	2130	3210	4780	

unit: mm

## Class 600

Nominal Size	NPS	2	3	4	6	8	10	12	14	16	18	20	24
	DN	50	80	100	150	200	250	300	350	400	450	500	600
Valve Operator		Gear											
Ball Bore	49	74	100	150	201	252	303	334	385	436	487	589	
L	292	356	432	559	660	787	838	889	991	1092	1194	1397	
H1	165	221	263	296	385	402	467	546	601	685	725	828	
H2	103	134	165	191	241	-	-	-	-	-	-	-	
H3	-	-	-	-	-	384	427	460	498	554	643	721	
A	52	105	53	130	140	182	182	209	67	279	279	343	
B	217	311	313	418	530	570	570	491	600	701	701	727	
D	200	300	300	500	600	600	800	800	800	800	800	800	
Weight (kg)	45	100	175	300	560	850	1180	1560	2200	3100	3970	6150	

unit: mm

# Valve Dimensions and Operators

< size unit : inch >

## Class 150

unit: inch

Nominal Size	NPS	2	3	4	6	8	10	12	14	16	18	20	24
	DN	50	80	100	150	200	250	300	350	400	450	500	600
Valve Operator		Lever	Gear										
Ball Bore		1.94	2.94	3.94	5.94	7.94	9.94	11.94	13.19	15.19	17.19	19.19	23.19
L		7.00	8.00	9.00	15.50	18.00	21.00	24.00	27.00	30.00	34.00	36.00	42.00
H1		7.17	7.40	9.21	11.14	13.74	15.67	18.23	19.02	22.91	24.09	28.50	31.77
H2		3.94	4.84	5.94	7.52	9.33	11.18	-	-	-	-	-	-
H3		-	-	-	-	-	-	16.81	17.52	19.65	20.71	24.37	27.48
A		-	2.05	2.80	3.39	2.09	5.12	5.12	5.12	7.17	7.17	2.64	2.64
B		-	8.54	11.10	12.01	15.59	22.32	22.32	22.32	22.44	22.44	23.62	23.62
D		11.81	7.87	11.81	19.69	19.69	19.69	23.62	23.62	31.50	31.50	31.50	31.50
Weight (lb.)		44	88	154	353	661	1058	1631	2161	2976	4409	5291	8598

## Class 300

unit: inch

Nominal Size	NPS	2	3	4	6	8	10	12	14	16	18	20	24
	DN	50	80	100	150	200	250	300	350	400	450	500	600
Valve Operator		Lever	Gear										
Ball Bore		1.94	2.94	3.94	5.94	7.94	9.94	11.94	13.19	15.19	17.19	19.19	23.19
L		8.50	11.13	12.00	15.88	19.75	22.38	25.50	30.00	33.00	36.00	39.00	45.00
H1		7.17	7.40	9.53	11.69	13.70	15.67	18.58	19.37	22.91	24.29	28.50	31.81
H2		3.92	4.84	5.93	7.50	9.33	11.18	-	-	-	-	-	-
H3		-	-	-	-	-	-	16.89	17.52	19.61	20.83	24.33	27.52
A		-	2.05	4.13	2.09	5.12	5.12	5.51	5.51	7.17	8.23	2.68	11.02
B		-	8.54	12.24	13.70	16.46	22.32	22.83	22.83	22.44	19.33	23.62	27.60
D		15.75	7.87	11.81	19.69	19.69	23.62	23.62	31.50	31.50	31.50	31.50	31.50
Weight (lb.)		55	121	198	485	794	1235	1874	2513	3483	4916	6063	10141

## Class 600

unit: inch

Nominal Size	NPS	2	3	4	6	8	10	12	14	16	18	20	24
	DN	50	80	100	150	200	250	300	350	400	450	500	600
Valve Operator			Gear										
Ball Bore		1.94	2.94	3.94	5.94	7.94	9.94	11.94	13.19	15.19	17.19	19.19	23.19
L		11.50	14.00	17.00	22.00	26.00	31.00	33.00	35.00	39.00	43.00	47.00	55.00
H1		6.61	8.70	10.35	11.65	14.33	15.83	18.39	21.50	23.66	26.95	28.54	32.59
H2		4.06	5.26	6.49	7.50	9.49	-	-	-	-	-	-	-
H3		-	-	-	-	-	15.12	16.81	18.11	19.61	21.81	25.31	28.39
A		2.05	4.13	2.09	5.12	5.51	7.17	7.17	8.23	2.64	10.98	10.98	13.50
B		8.54	12.24	12.32	16.46	20.87	22.44	22.44	19.33	23.62	27.60	27.60	28.62
D		7.87	11.81	11.81	19.69	23.62	23.62	31.50	31.50	31.50	31.50	31.50	31.50
Weight (lb.)		88	176	353	706	1279	1874	2535	3527	4850	6614	8157	12566

## Pressure-Temperature Ratings

The pressure-temperature rating of KITZ trunnion mounted ball valves are determined, not only by the valve shell materials, but also by the sealing materials used for ball seats, gland packings, O-rings, flange gaskets and bearings. In case of soft seated, sealing materials may be high molecule or rubber, but the choice is limited by characteristics of the service fluid, working pressures, fluid velocity, and operation frequency of valves.

As it is very difficult to predetermine the exact pressure-temperature ratings for all kinds of fluid under all imaginable conditions, general rating charts have been provided for non-shock fluid service below, based on our past experiences both in the field and our own laboratory. Frequent need of maintenance is another factor to be kept in mind, if extremely high temperature operation is planned or expected.

### T60S Pressure-Temperature Rating

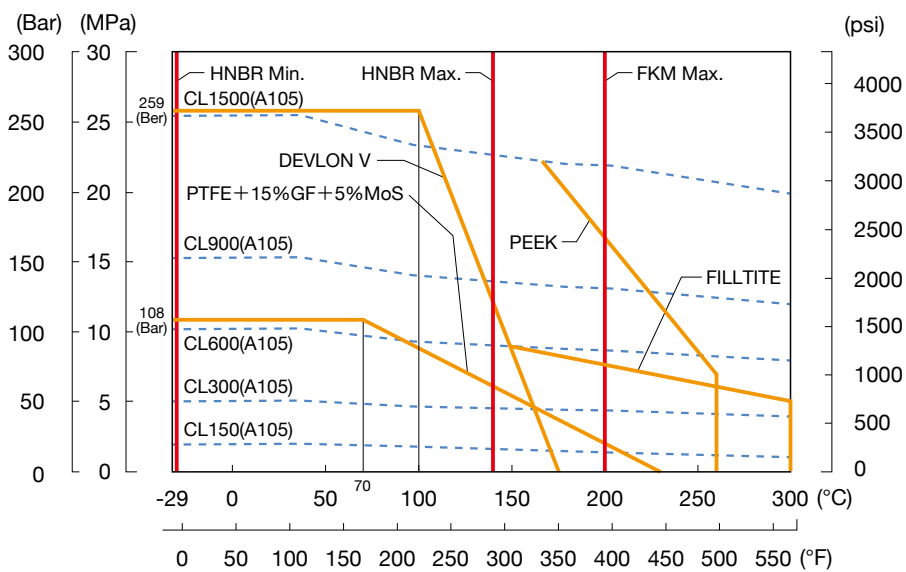

O-Ring Material	Min.Temp. (°C/°F)	Max.Temp. (°C/°F)
NBR	-30/-22	80/176
HNBR	-30/-22	140/284
L-NBR	-46/-51	80/176
L-HNBR	-46/-50	140/284
FKM	-20/-4	200/392

### T60M Pressure-Temperature Rating

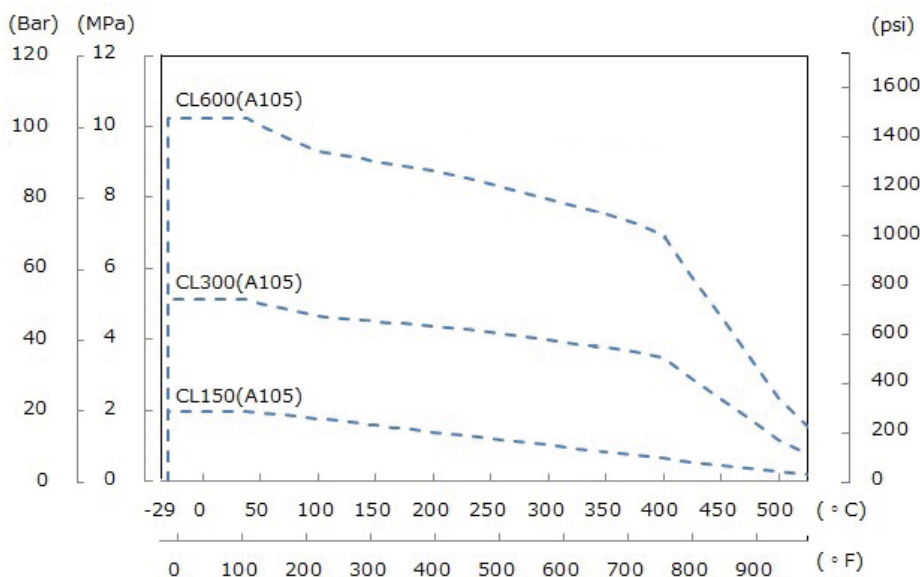

NOTE : Please contact KITZ Corporation, if T60M valves are to be used for temperature greater than 400°C/752°F

## Engineering Data

### Flow Coefficient (Cv)

#### T60S and T60M Full bore

Nominal Size	NPS	2	3	4	6	8	10	12	14	16	18	20	24
	DN	50	80	100	150	200	250	300	350	400	450	500	600
Class	150	500	1200	2500	5200	10400	17300	26100	32000	44000	57000	74000	111000
	300	420	1050	2100	5200	9900	16800	25400	30100	41500	55000	70500	108000
	600	400	1000	1850	4400	8700	14500	22500	28000	38200	50300	64000	97000
	900	330	900	1750	4300	8400	14000	21000	24000	34000	45000	56000	85000
	1500	330	810	1650	3800	7200	11500	17000	21000	27500	36500	46000	67500

### Valve Operating Torque

< Torque unit : N·m >

#### T60S Class 150 / 300

Nominal Size	NPS	2	3	4	6	8	10	12	14	16	18	20	24
	DN	50	80	100	150	200	250	300	350	400	450	500	600
Differential Pressure (MPa)	0.5	43	82	121	298	408	647	881	980	1325	1587	2139	3121
	1	46	86	130	337	497	776	1110	1252	1695	2116	2876	4362
	2	51	98	153	421	668	1031	1542	1763	2388	3086	4222	6594
	3	53	103	166	469	774	1186	1811	2084	2824	3702	5080	8033
	4	59	112	183	530	892	1364	2109	2434	3299	4363	5998	9546
	5	61	117	195	572	978	1491	2324	2690	3645	4848	6670	10663

#### T60S Class 600

Nominal Size	NPS	2	3	4	6	8	10	12	14	16	18	20	24
	DN	50	80	100	150	200	250	300	350	400	450	500	600
Differential Pressure (MPa)	0.5	66	100	153	299	524	650	972	1063	1477	1746	2543	3526
	2	70	114	185	423	763	1035	1621	1836	2514	3251	4557	6929
	4	75	126	212	532	974	1368	2179	2499	3406	4540	6282	9829
	6	86	148	255	664	1225	1747	2804	3232	4397	5931	8167	12923
	8	104	182	316	846	1564	2252	3627	4191	5697	7734	10622	16910
	10	121	216	377	1027	1905	2756	4450	5152	6997	9538	13078	20898

#### T60S Class 900

Nominal Size	NPS	2	3	4	6	8	10	12	14	16	18	20	24
	DN	50	80	100	150	200	250	300	350	400	450	500	600
Differential Pressure (MPa)	0.5	96	118	182	357	610	779	1162	1908	2252	2414	3385	5596
	5	106	158	269	668	1193	1700	2708	3621	4690	5369	7896	13742
	7.5	135	210	362	929	1667	2404	3854	5011	6600	7606	11237	19477
	10	165	262	455	1189	2141	3107	4999	6466	8510	9844	14579	25557
	12.5	184	298	521	1378	2484	3621	5838	7494	9899	11478	17025	29891
	15	212	347	609	1625	2935	4289	6926	8846	11714	13603	20200	35503

#### T60S Class 1500

Nominal Size	NPS	2	3	4	6	8	10	12	14	16	18	20	24
	DN	50	80	100	150	200	250	300	350	400	450	500	600
Differential Pressure (MPa)	0.5	96	154	245	492	725	1078	1875	1931	2832	2973	4556	5604
	5	106	187	323	803	1346	2098	3457	3738	5633	6383	10126	13755
	10	165	299	530	1391	2393	3763	6142	6699	10144	11640	18566	25580
	15	212	391	700	1880	3269	5157	8385	9177	13922	16053	25655	35534
	20	254	472	850	2310	4040	6385	10359	11360	17249	19939	31900	44306
	25	290	541	979	2682	4706	7446	12065	13246	20125	23300	37301	51896



< Torque unit : in-lb >

**T60S Class 150 / 300**

unit: in-lb

Nominal Size	NPS	2	3	4	6	8	10	12	14	16	18	20	24
	DN	50	80	100	150	200	250	300	350	400	450	500	600
Differential Pressure (PSIG)	100	388	738	1100	2765	3909	6161	8568	9586	12966	15822	21398	31783
	150	404	763	1158	3005	4447	6946	9956	11234	15212	19024	25857	39275
	300	450	866	1365	3757	5977	9217	13808	15795	21398	27686	37888	59225
	450	476	917	1488	4209	6953	10654	16297	18760	25421	33366	45795	72464
	600	521	996	1636	4744	7996	12223	18922	21848	29619	39198	53898	85834
	740	543	1040	1736	5100	8729	13311	20766	24035	32573	43340	59640	95373

**T60S Class 600**

unit: in-lb

Nominal Size	NPS	2	3	4	6	8	10	12	14	16	18	20	24
	DN	50	80	100	150	200	250	300	350	400	450	500	600
Differential Pressure (PSIG)	100	591	902	1392	2784	4904	6183	9331	10274	14229	17134	24755	35006
	300	623	1016	1642	3772	6817	9259	14516	16446	22521	29164	40847	62200
	600	674	1129	1901	4786	8769	12333	19661	22557	30743	41018	56734	88863
	900	776	1342	2310	6044	11146	15921	25564	29473	40091	54124	74505	117993
	1350	1018	1806	3149	8536	15812	22846	36862	42652	57939	78886	108220	172733
	1480	1085	1940	3392	9252	17163	24846	40125	46463	63095	86043	117960	188546

**T60S Class 900**

unit: in-lb

Nominal Size	NPS	2	3	4	6	8	10	12	14	16	18	20	24
	DN	50	80	100	150	200	250	300	350	400	450	500	600
Differential Pressure (PSIG)	100	850	1058	1639	3276	5620	7241	10863	17523	20840	22463	31641	52561
	740	948	1402	2376	5910	10555	15044	23966	32044	41502	47513	69877	121616
	1000	1135	1748	3002	7661	13738	19769	31657	41380	54327	62536	92313	160118
	1480	1472	2342	4073	10664	19199	27877	44858	57979	76330	88316	130817	229351
	1800	1611	2597	4540	12002	21638	31524	50815	65285	86200	99923	148195	260146
	2220	1878	3068	5390	14385	25972	37961	61296	78287	103667	120390	178766	314199

**T60S Class 1500**

unit: in-lb

Nominal Size	NPS	2	3	4	6	8	10	12	14	16	18	20	24
	DN	50	80	100	150	200	250	300	350	400	450	500	600
Differential Pressure (PSIG)	100	850	1376	2197	4468	6647	9919	17185	17762	26112	27583	42395	52636
	740	948	1674	2893	7210	12101	18870	31090	33622	50681	57454	91163	123901
	1480	1474	2683	4752	12486	21503	33815	55175	60195	91159	104634	166902	230028
	2220	1897	3502	6271	16844	29304	46234	75156	82273	124818	143944	230059	318713
	3000	2289	4261	7681	20898	36567	57800	93760	102834	156166	180567	288908	401374
	3705	2562	4791	8665	23733	41650	65894	106776	117223	178107	206208	330115	459276

NOTES :

- (1) All torque values include a 30% safety factor. Values are for clean, static water at ambient temperature.
- (2) Ball seat material: RPTFE (PTFE + 15% Glass filled + 5% MoS2)
- (3) In case of using higher safety factor than 30%, please confirm the maximum allowable stem strength (MAST).

< weight unit : kg >

**T60S Weight**

unit: kg

Nominal Size	NPS	2	3	4	6	8	10	12	14	16	18	20	24
	DN	50	80	100	150	200	250	300	350	400	450	500	600
Class	150	21	37	64	171	327	552	783	1017	1496	1898	2612	4044
	300	25	48	83	191	359	598	836	1111	1613	2074	2906	4460
	600	37	73	133	318	555	832	1194	1477	2164	2812	3992	5950
	900	65	95	170	400	700	1110	1730	2153	2960	3980	5830	10020
	1500	65	135	275	600	1130	1920	3330	3650	5490	7590	10280	15590

< weight unit : lbs >

unit: lbs

Nominal Size	NPS	2	3	4	6	8	10	12	14	16	18	20	24
	DN	50	80	100	150	200	250	300	350	400	450	500	600
Class	150	46	82	141	377	721	1217	1726	2242	3298	4184	5758	8915
	300	55	106	183	421	791	1318	1843	2449	3556	4572	6407	9833
	600	82	161	293	701	1224	1834	2632	3256	4771	6199	8801	13118
	900	143	209	375	882	1543	2447	3814	4747	6526	8774	12853	22090
	1500	143	298	606	1323	2491	4233	7341	8047	12103	16733	22663	34370

# F18TK-T60 Series

## Soft Seated 3-Piece Body Trunnion Mounted Ball Valves

Trunnion mounted side entry steel ball valves are designed to meet API 6D/ISO 14313 and other referential international valve design standards, used for petroleum, petrochemical, oil, gas and any industrials.

### General Design Standard

- Basic design: API 6D/ISO 14313
- F –F dimensions: API 6D/ASME B16.10
- End connection: ASME B16.5
- Bore diameter: API 6D/ISO 14313
- Wall thickness: ASME B16.34

### Design Features

- Structure: 3-piece bolted body and cap
- Tight shut-off sealing mechanism
- Low operation torque
- Double block and bleed function
- Self-relief of excessive cavity pressure
- Fire safe tested
- Blowout-proof stem construction
- Antistatic provision design
- Locking device for lever operation
- ISO 5211 actuator mounting pad
- PN design can be available

### Certification

- Fugitive emission: ISO 15848-1 BH CO1
- Fire test: ISO 10497/API 607
- PED 2014/68/EU
- ATEX 2014/34/EU



### Product Range

- Nominal pressure: ASME Class 150 to 2500
- Nominal size: NPS 1/2 to NPS 36  
(DN 15 to 900)
- Shell materials:  
Carbon and low alloy steel, Austenitic stainless steel, Duplex stainless steel, High alloy steel, Nickel based alloy
- Ball seat materials:  
RPTFE (Reinforced PTFE), Modified PTFE, RNylon, DEVLON, PCTFE, PEEK

### Option

- NACE MR 0175 available
- Pneumatic and electric actuator
- Thru-conduit bore
- Grease injection point for seat and stem
- Stem extension



This illustration shows typical construction for size up to NPS 4

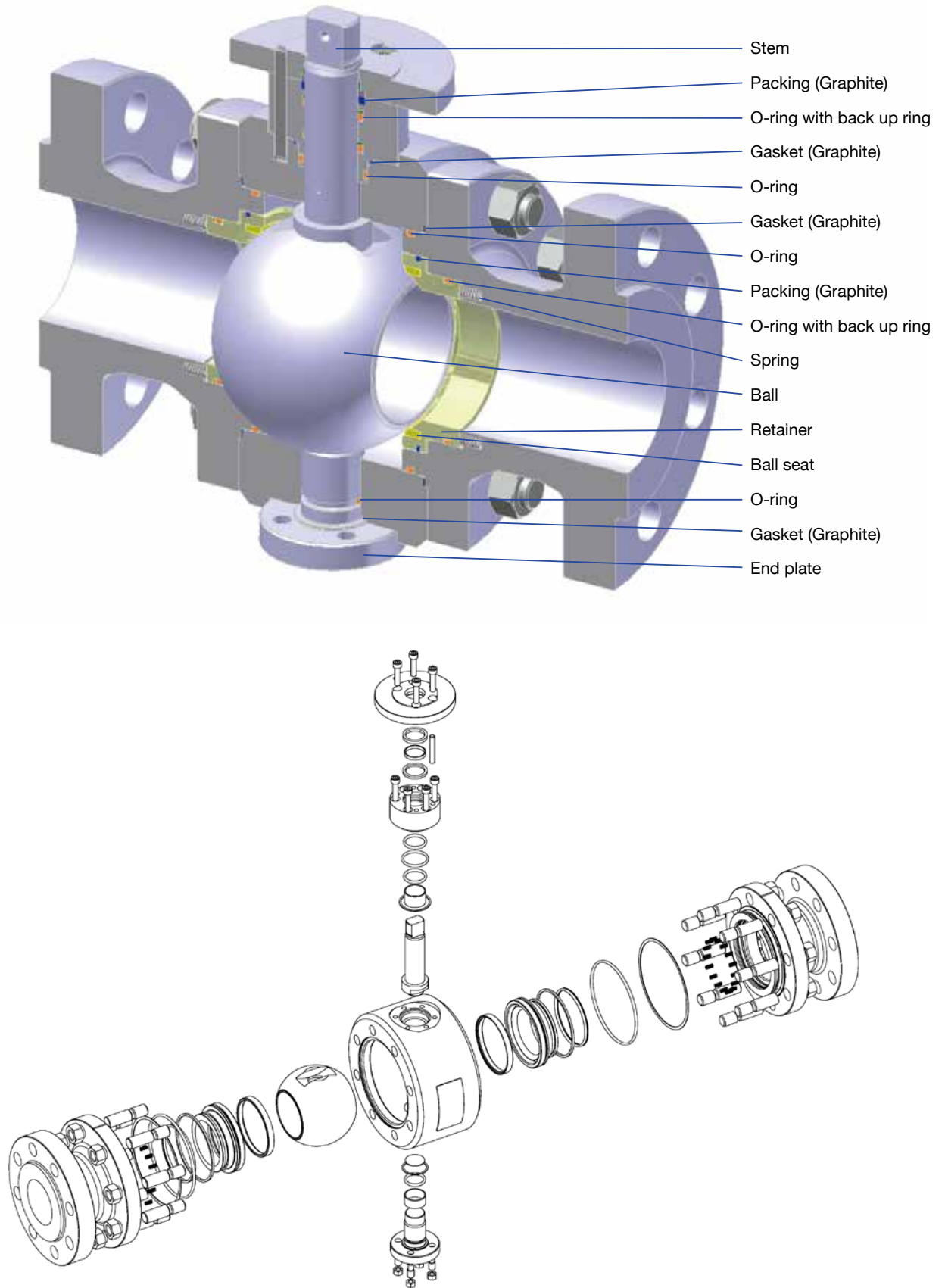

This illustration shows typical construction for size NPS 6 and larger

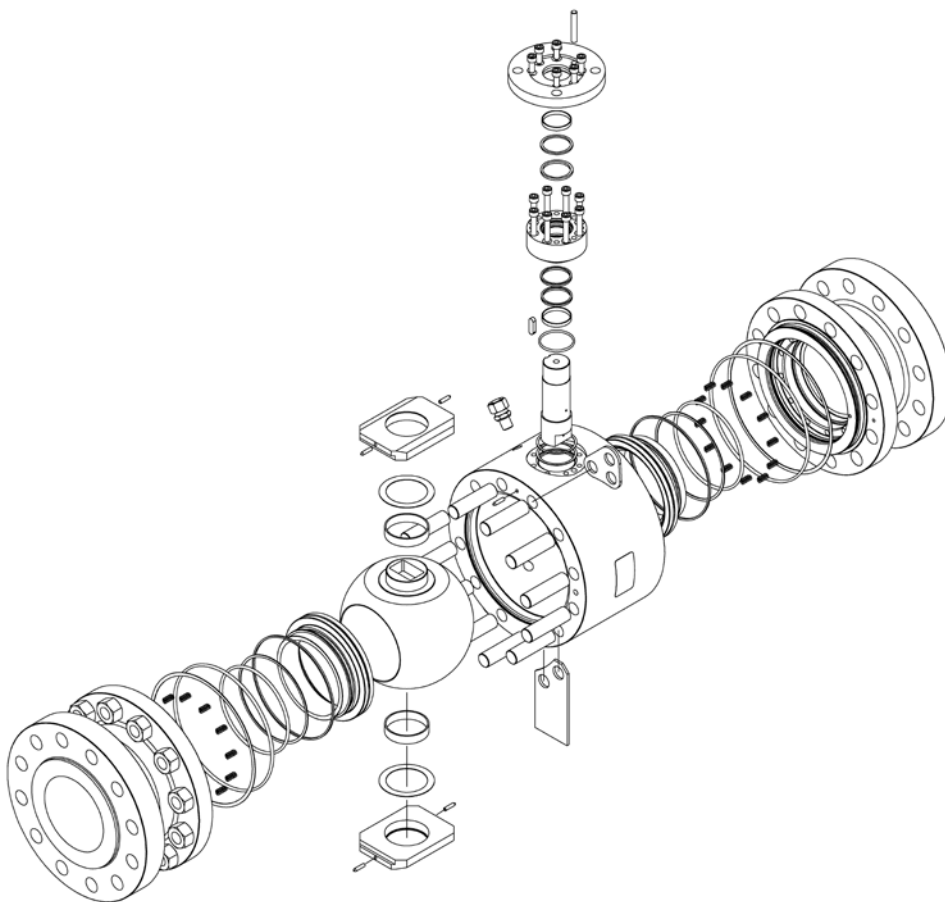
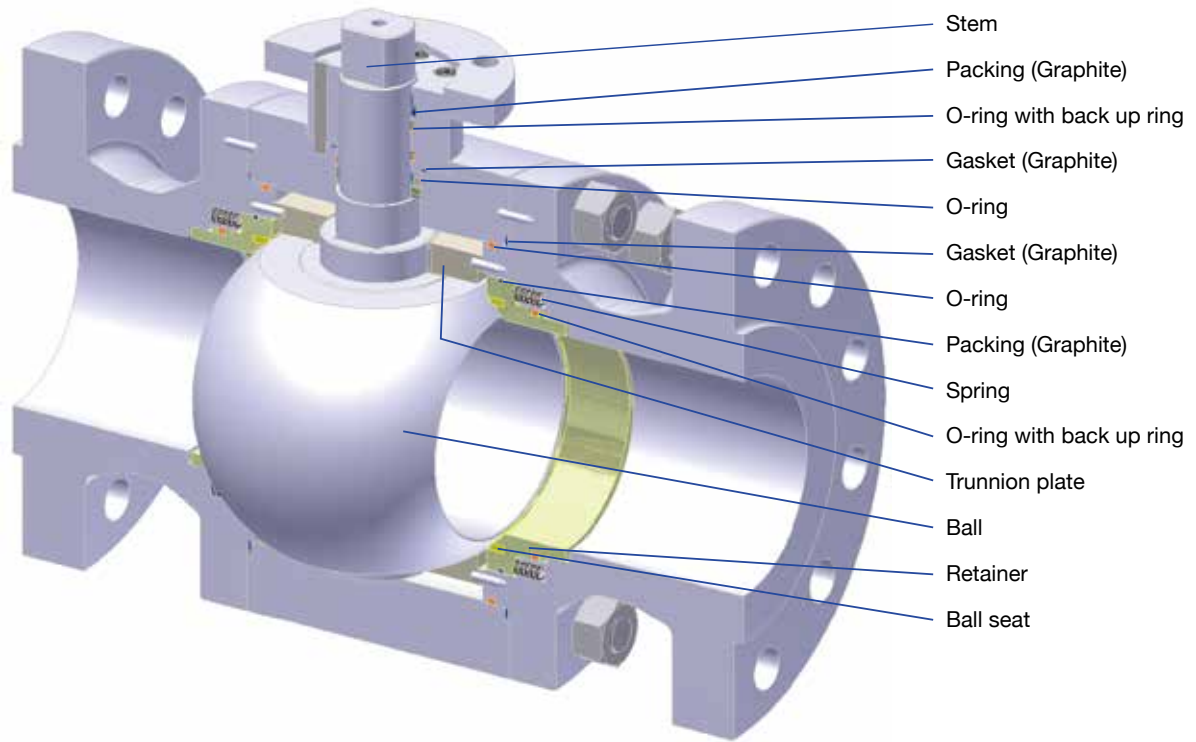

## Design Features

### Tight Shut-off Sealing Mechanism

The resilient seat design adequately maintains each of the upstream and downstream ball seats in contact with the ball by means of repulsing force of seat springs inserted behind the seat retainers. Line fluid pressure also helps this contact method. This sealing mechanism features unfailing thru-the-bore sealing performance of upstream and downstream side ball seats at the same time.

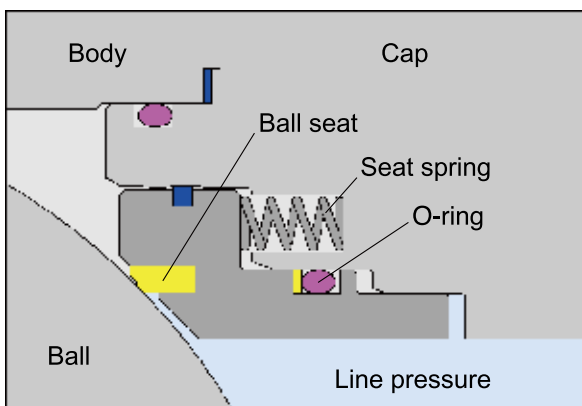

### Double Block and Bleed Function

Ball seats independently shut off the line fluid on the upstream and downstream side of the ball. The valve bore and the body cavity are isolated from each other when the valve is fully open or closed. Under this condition, the cavity pressure can be discharged with a vent valve and a drain plug. The vent valve is equipped with a blowout-proof bleeder for safe

discharge. Relieving the cavity pressure with a vent valve is recommended for safe draining.

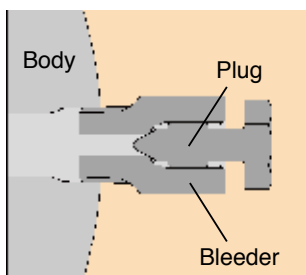

### Fire Safe Design

#### 1) Internal leakage prevention

When resilient sealing materials are damaged or decomposed by a plant fire, edges of upstream and downstream metal seat retainers preloaded by seat springs come into contact with the ball to shut off line fluid to minimize internal leakage through the valve bore. Meanwhile, flexible graphite seat retainer packing rings of KITZ original design prevent fluid leakage from between the valve caps and seat retainers during and after the plant fire.

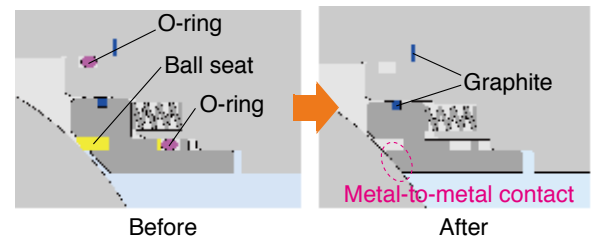

#### 2) External leakage prevention

External leakage from the valve stem area is prevented by double sealing with O-ring and flexible graphite gland packing ring. Leakage through the valve body joint is protected by flexible graphite gaskets. Even after a fire has destroyed O-rings, flexible graphite gland packing ring and gaskets remain intact to prevent external fluid leakage.

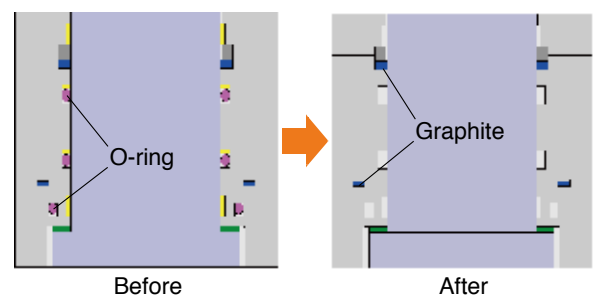

## Design Features

### Self Cavity Pressure Relief

In case of incidental rise of servicing or ambient temperature, liquefied gas or highly volatile liquid trapped within the body cavity may vaporize, and cause an excessive rise in the cavity pressure. For safety consideration, when the cavity pressure exceeds the line pressure, either one of the ball seats will move slightly away from the ball surface together with seat retainers to relieve the excessive cavity pressure into the valve bore.

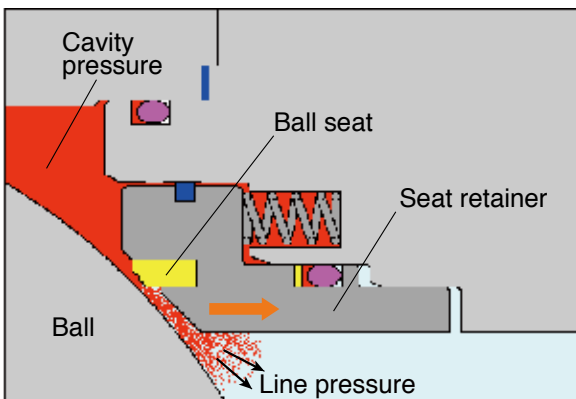

### Anti Static Design

Spring loaded balls assembled between the stem and the bonnet and between the stem and the ball permits electric conductivity through all metallic valve components.

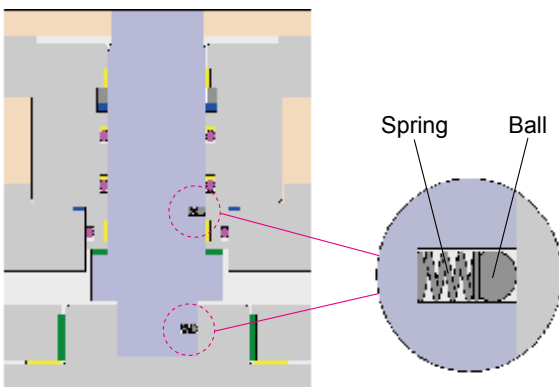

### Emergency Grease Injection (option)\*

For accidental leakage from the ball seat or stem sealing area, a sealant supply mechanism may be provided as an option. Should materials be damaged or decomposed by a fire or other accidental causes, leakage can be temporarily prevented or reduced by sealant injection into this mechanism.

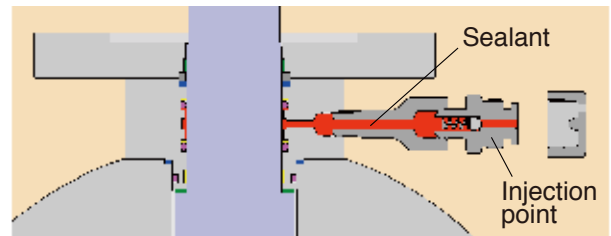
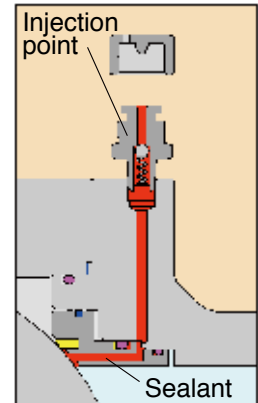

### Thru-Conduit Bore (option)

Besides the standard full bore, the custom sized thru-conduit bore is optionally available for use of pipeline scrapers or cleaning pigs.

### Stem Extension

An optional stem extension design is available for underground or remote valve operation. Specify the dimension between the center of the valve bore and the center of the valve operator. Valve operating medium such as electric and pneumatic actuators are also optionally available.



\*Standard Design for North America.

## Material Example/Pressure-Temperature Rating

### Material Example

Service	Non-corrosive	Low Temp.	Corrosive	Sour	
Body/Cap	A105	LF2	F316	F51 or S31803	F55 or S32760
Stem	13Cr or 630SS	316SS or 630SS	316SS or S31803	S31803	S32760
Ball	13Cr or A105+ENP	316SS or LF2+ENP	316SS	F51 or S31803	F55 or S32760
Seat Retainer	A105+ENP	LF2+ENP	316SS	S31803	S32760
Ball Seat	RPTFE (class up to 600) RNylon (class 900 and over)				
Spring	AISI 301	AISI 301	Inconel X750	Inconel X750	Inconel X750
O-ring	HNBR	L-NBR	FKM	FKM	FKM
Bolt	B7	L7	B8	B8	B8
Nut	2H	4	8	8	8

### Pressure-Temperature Rating

The pressure-temperature rating of KITZ trunnion mounted ball valves are determined, not only by the valve shell materials, but also by the sealing materials used for ball seats, gland packings, O-rings, flange gaskets and bearings. In case of soft seated, sealing materials may be high molecule or rubber, but the choice is limited by characteristics of the service fluid, working pressures, fluid velocity, and operation frequency of valves.

As it is very difficult to predetermine the exact pressure-temperature ratings for all kinds of fluid under all imaginable conditions, general rating charts have been provided for non-shock fluid service below, based on our past experiences both in the field and our own laboratory. Frequent need of maintenance is another factor to be kept in mind, if extremely high temperature operation is planned or expected.

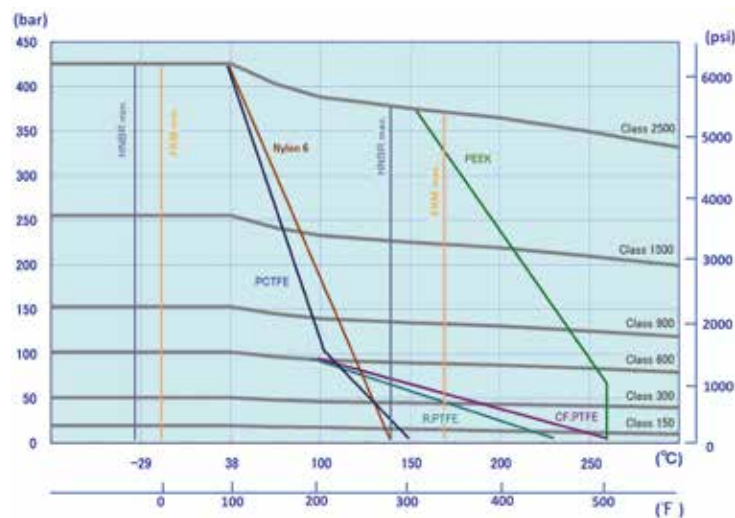

# Dimensions

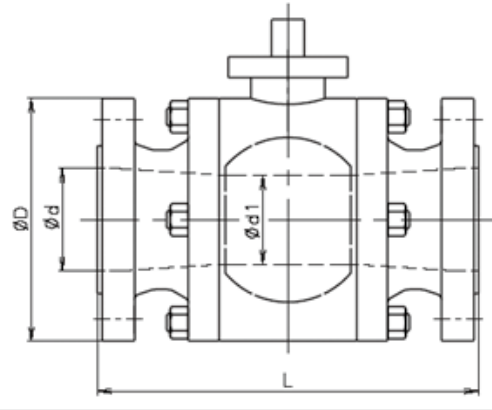

< size unit : mm >

## Class 150

unit: mm

SIZE (NPS)	d	d1	D	L		
				RF	WE	RJ
1/2	13	13	90	165	165	163
3/4 x 1/2	19	13	100	165	165	165
3/4	19	19	100	165	165	165
1 x 3/4	25	19	110	165	165	165
1	25	25	110	165	165	165
1 1/2 x 1	38	25	125	165	190	178
1 1/2	38	38	125	165	190	178
2 x 1 1/2	49	38	150	178	216	191
2 to 24	Please refer to T60S (p. 9)					
26 x 20	633	487	870	1143	1245	-
26 x 22	633	538	870	1143	1245	-
26 x 24	633	589	870	1143	1245	-
26	633	633	870	1143	1245	-
28 x 22	684	538	925	1245	1346	-
28 x 24	684	589	925	1245	1346	-
28 x 26	684	633	925	1245	1346	-
28	684	684	925	1245	1346	-
30 x 24	735	589	985	1295	1397	-
30 x 26	735	633	985	1295	1397	-
30 x 28	735	684	985	1295	1397	-
30	735	735	985	1295	1397	-
32 x 26	779	633	1060	1372	1524	-
32 x 28	779	684	1060	1372	1524	-
32 x 30	779	735	1060	1372	1524	-
32	779	779	1060	1372	1524	-
34 x 28	830	684	1110	1473	1626	-
34 x 30	830	735	1110	1473	1626	-
34 x 32	830	779	1110	1473	1626	-
34	830	830	1110	1473	1626	-
36 x 30	874	735	1170	1524	1727	-
36 x 32	874	779	1170	1524	1727	-
36 x 34	874	830	1170	1524	1727	-
36	874	874	1170	1524	1727	-

## Class 300

unit: mm

SIZE (NPS)	d	d1	D	L		
				RF	WE	RJ
1/2	13	13	95	165	165	163
3/4 x 1/2	19	13	115	165	165	178
3/4	19	19	115	165	165	178
1 x 3/4	25	19	125	165	165	178
1	25	25	125	165	165	178
1 1/2 x 1	38	25	155	190	190	203
1 1/2	38	38	155	190	190	203
2 x 1 1/2	49	38	165	216	216	232
2 to 24	Please refer to T60S (p. 9)					
26 x 20	633	487	970	1245	1245	1270
26 x 22	633	538	970	1245	1245	1270
26 x 24	633	589	970	1245	1245	1270
26	633	633	970	1245	1245	1270
28 x 22	684	538	1035	1346	1346	1372
28 x 24	684	589	1035	1346	1346	1372
28 x 26	684	633	1035	1346	1346	1372
28	684	684	1035	1346	1346	1372
30 x 24	735	589	1090	1397	1397	1422
30 x 26	735	633	1090	1397	1397	1422
30 x 28	735	684	1090	1397	1397	1422
30	735	735	1090	1397	1397	1422
32 x 26	779	633	1150	1524	1524	1553
32 x 28	779	684	1150	1524	1524	1553
32 x 30	779	735	1150	1524	1524	1553
32	779	779	1150	1524	1524	1553
34 x 28	830	684	1205	1626	1626	1654
34 x 30	830	735	1205	1626	1626	1654
34 x 32	830	779	1205	1626	1626	1654
34	830	830	1205	1626	1626	1654
36 x 30	874	735	1270	1727	1727	1756
36 x 32	874	779	1270	1727	1727	1756
36 x 34	874	830	1270	1727	1727	1756
36	874	874	1270	1727	1727	1756

## Class 600

unit: mm

SIZE (NPS)	d	d1	D	L		
				RF	WE	RJ
1/2	13	13	95	165	165	163
3/4 x 1/2	19	13	115	190	190	190
3/4	19	19	115	190	190	190
1 x 3/4	25	19	125	216	216	216
1	25	25	125	216	216	216
1 1/2 x 1	38	25	155	241	241	241
1 1/2	38	38	155	241	241	241
2 x 1 1/2	49	38	165	292	292	295
2 to 24	Please refer to T60S (p. 10)					
26 x 20	633	487	1015	1448	1448	1461
26 x 22	633	538	1015	1448	1448	1461
26 x 24	633	589	1015	1448	1448	1461
26	633	633	1015	1448	1448	1461
28 x 22	684	538	1075	1549	1549	1562
28 x 24	684	589	1075	1549	1549	1562
28 x 26	684	633	1075	1549	1549	1562
28	684	684	1075	1549	1549	1562
30 x 24	735	589	1130	1651	1651	1664
30 x 26	735	633	1130	1651	1651	1664
30 x 28	735	684	1130	1651	1651	1664
30	735	735	1130	1651	1651	1664
32 x 26	779	633	1195	1778	1778	1794
32 x 28	779	684	1195	1778	1778	1794
32 x 30	779	735	1195	1778	1778	1794
32	779	779	1195	1778	1778	1794
34 x 28	830	684	1245	1930	1930	1946
34 x 30	830	735	1245	1930	1930	1946
34 x 32	830	779	1245	1930	1930	1946
34	830	830	1245	1930	1930	1946
36 x 30	874	735	1315	2083	2083	2099
36 x 32	874	779	1315	2083	2083	2099
36 x 34	874	830	1315	2083	2083	2099
36	874	874	1315	2083	2083	2099

NOTE: PN designed valves can be available. Please ask product range and dimensions.



# Dimensions

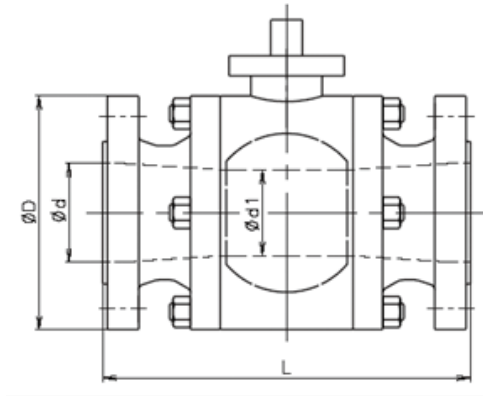

## Class 900

unit: mm

SIZE (NPS)	d	d1	D	L		
				RF	WE	RJ
1/2	13	13	120	216	216	216
3/4 x 1/2	19	13	130	229	229	229
3/4	19	19	130	229	229	229
1 x 3/4	25	19	150	254	254	254
1	25	25	150	254	254	254
1 1/2 x 1	38	25	180	305	305	305
1 1/2	38	38	180	305	305	305
2 x 1 1/2	49	38	215	368	368	371
2 to 24	Please refer to T60S (p. 10)					

## Class 1500

unit: mm

SIZE (NPS)	d	d1	D	L		
				RF	WE	RJ
1/2	13	13	120	216	216	216
3/4 x 1/2	19	13	130	229	229	229
3/4	19	19	130	229	229	229
1 x 3/4	25	19	150	254	254	254
1	25	25	150	254	254	254
1 1/2 x 1	38	25	180	305	305	305
1 1/2	38	38	180	305	305	305
2 x 1 1/2	49	38	215	368	368	371
2 to 24	Please refer to T60S (p. 10)					

## Class 2500

unit: mm

SIZE (NPS)	d	d1	D	L		
				RF	WE	RJ
1/2	13	13	135	264	264	264
3/4 x 1/2	19	13	140	273	273	273
3/4	19	19	140	273	273	273
1 x 3/4	25	19	160	308	308	308
1	25	25	160	308	308	308
1 1/2 x 1	38	25	205	384	384	387
1 1/2	38	38	205	384	384	387
2 x 1 1/2	42	38	235	451	451	454
2	42	42	235	451	451	454
3 x 2	62	42	305	578	578	584
3	62	62	305	578	578	584
4 x 3	87	62	355	673	673	683
4	87	87	355	673	673	683
6 x 4	131	87	485	914	914	927
6	131	131	485	914	914	927
8 x 6	179	131	550	1022	1022	1038
8	179	179	550	1022	1022	1038

NOTE: PN designed valves can be available. Please ask product range and dimensions.

# Dimensions

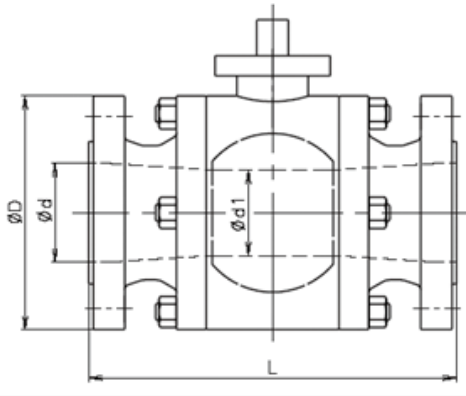

< size unit : inch >

## Class 150

unit: inch

SIZE (NPS)	d	d1	D	L		
				RF	WE	RJ
1/2	0.50	0.50	3.50	6.50	6.50	6.44
3/4 x 1/2	0.75	0.5	3.88	6.50	6.50	6.50
3/4	0.75	0.75	3.88	6.50	6.50	6.50
1 x 3/4	1.00	0.75	4.25	6.50	6.50	6.50
1	1.00	1.00	4.25	6.50	6.50	6.50
1 1/2 x 1	1.50	1.00	5.00	6.50	7.50	7.00
1 1/2	1.50	1.50	5.00	6.50	7.50	7.00
2 x 1 1/2	1.94	1.50	6.00	7.00	8.50	7.50
2 to 24	Please refer to T60S (p. 10)					
26 x 20	24.94	19.19	34.25	45.00	49.00	-
26 x 22	24.94	21.19	34.25	45.00	49.00	-
26 x 24	24.94	23.19	34.25	45.00	49.00	-
26	24.94	24.19	34.25	45.00	49.00	-
28 x 22	26.94	21.19	36.50	49.00	53.00	-
28 x 24	26.94	23.19	36.50	49.00	53.00	-
28 x 26	26.94	24.19	36.50	49.00	53.00	-
28	26.94	26.94	36.50	49.00	53.00	-
30 x 24	28.94	23.19	38.75	51.00	55.00	-
30 x 26	28.94	24.19	38.75	51.00	55.00	-
30 x 28	28.94	26.94	38.75	51.00	55.00	-
30	28.94	28.94	38.75	51.00	55.00	-
32 x 26	30.69	24.19	41.75	54.00	60.00	-
32 x 28	30.69	26.94	41.75	54.00	60.00	-
32 x 30	30.69	28.94	41.75	54.00	60.00	-
32	30.69	30.69	41.75	54.00	60.00	-
34 x 28	32.69	26.94	43.75	58.00	64.00	-
34 x 30	32.69	28.94	43.75	58.00	64.00	-
34 x 32	32.69	30.69	43.75	58.00	64.00	-
34	32.69	32.69	43.75	58.00	64.00	-
36 x 30	34.44	28.94	46.00	60.00	68.00	-
36 x 32	34.44	30.69	46.00	60.00	68.00	-
36 x 34	34.44	32.69	46.00	60.00	68.00	-
36	34.44	34.44	46.00	60.00	68.00	-

## Class 300

unit: inch

SIZE (NPS)	d	d1	D	L		
				RF	WE	RJ
1/2	0.50	0.50	3.75	6.50	6.50	6.44
3/4 x 1/2	0.75	0.50	4.62	6.50	6.50	7.00
3/4	0.75	0.75	4.62	6.50	6.50	7.00
1 x 3/4	1.00	0.75	4.88	6.50	6.50	7.00
1	1.00	1.00	4.88	6.50	6.50	7.00
1 1/2 x 1	1.50	1.00	6.12	7.50	8.00	8.00
1 1/2	1.50	1.50	6.12	7.50	8.00	8.00
2 x 1 1/2	1.94	1.50	6.50	8.50	8.50	9.13
2 to 24	Please refer to T60S (p. 10)					
26 x 20	24.94	19.19	38.25	49.00	49.00	50.00
26 x 22	24.94	21.19	38.25	49.00	49.00	50.00
26 x 24	24.94	23.19	38.25	49.00	49.00	50.00
26	24.94	24.19	38.25	49.00	49.00	50.00
28 x 22	26.94	21.19	40.75	53.00	53.00	54.00
28 x 24	26.94	23.19	40.75	53.00	53.00	54.00
28 x 26	26.94	24.19	40.75	53.00	53.00	54.00
28	26.94	26.94	40.75	53.00	53.00	54.00
30 x 24	28.94	23.19	43.00	55.00	55.00	56.00
30 x 26	28.94	24.19	43.00	55.00	55.00	56.00
30 x 28	28.94	26.94	43.00	55.00	55.00	56.00
30	28.94	28.94	43.00	55.00	55.00	56.00
32 x 26	30.69	24.19	45.25	60.00	60.00	61.13
32 x 28	30.69	26.94	45.25	60.00	60.00	61.13
32 x 30	30.69	28.94	45.25	60.00	60.00	61.13
32	30.69	30.69	45.25	60.00	60.00	61.13
34 x 28	32.69	26.94	47.50	64.00	64.00	65.13
34 x 30	32.69	28.94	47.50	64.00	64.00	65.13
34 x 32	32.69	30.69	47.50	64.00	64.00	65.13
34	32.69	32.69	47.50	64.00	64.00	65.13
36 x 30	34.44	28.94	50.00	68.00	68.00	69.13
36 x 32	34.44	30.69	50.00	68.00	68.00	69.13
36 x 34	34.44	32.69	50.00	68.00	68.00	69.13
36	34.44	34.44	50.00	68.00	68.00	69.13

## Class 600

unit: inch

SIZE (NPS)	d	d1	D	L		
				RF	WE	RJ
1/2	0.50	0.50	3.75	6.50	6.50	6.44
3/4 x 1/2	0.75	0.5	4.62	7.50	7.50	7.50
3/4	0.75	0.75	4.62	7.50	7.50	7.50
1 x 3/4	1.00	0.75	4.88	8.50	8.50	8.50
1	1.00	1.00	4.88	8.50	8.50	8.50
1 1/2 x 1	1.50	1.00	6.12	9.50	9.50	9.50
1 1/2	1.50	1.50	6.12	9.50	9.50	9.50
2 x 1 1/2	1.94	1.50	6.50	11.50	11.50	11.50
2 to 24	Please refer to T60S (p. 11)					
26 x 20	24.94	19.19	40.00	57.00	57.00	57.50
26 x 22	24.94	21.19	40.00	57.00	57.00	57.50
26 x 24	24.94	23.19	40.00	57.00	57.00	57.50
26	24.94	24.19	40.00	57.00	57.00	57.50
28 x 22	26.94	21.19	42.25	61.00	61.00	61.50
28 x 24	26.94	23.19	42.25	61.00	61.00	61.50
28 x 26	26.94	24.19	42.25	61.00	61.00	61.50
28	26.94	26.94	42.25	61.00	61.00	61.50
30 x 24	28.94	23.19	44.50	65.00	65.00	65.50
30 x 26	28.94	24.19	44.50	65.00	65.00	65.50
30 x 28	28.94	26.94	44.50	65.00	65.00	65.50
30	28.94	28.94	44.50	65.00	65.00	65.50
32 x 26	30.69	24.19	47.00	70.00	70.00	70.63
32 x 28	30.69	26.94	47.00	70.00	70.00	70.63
32 x 30	30.69	28.94	47.00	70.00	70.00	70.63
32	30.69	30.69	47.00	70.00	70.00	70.63
34 x 28	32.69	26.94	49.00	76.00	76.00	76.63
34 x 30	32.69	28.94	49.00	76.00	76.00	76.63
34 x 32	32.69	30.69	49.00	76.00	76.00	76.63
34	32.69	32.69	49.00	76.00	76.00	76.63
36 x 30	34.44	28.94	51.75	82.00	82.00	82.63
36 x 32	34.44	30.69	51.75	82.00	82.00	82.63
36 x 34	34.44	32.69	51.75	82.00	82.00	82.63
36	34.44	34.44	51.75	82.00	82.00	82.63

NOTE: PN designed valves can be available. Please ask product range and dimensions.

# Dimensions

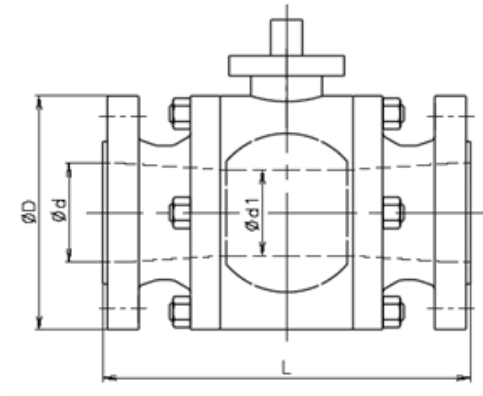

## Class 900

unit: inch

SIZE (NPS)	d	d1	D	L		
				RF	WE	RJ
1/2	0.50	0.50	4.75	8.50	8.50	8.50
3/4 x 1/2	0.75	0.50	5.12	9.00	9.00	9.00
3/4	0.75	0.75	5.12	9.00	9.00	9.00
1 x 3/4	1.00	0.75	5.88	10.00	10.00	10.00
1	1.00	1.00	5.88	10.00	10.00	10.00
1 1/2 x 1	1.50	1.00	7.00	12.00	12.00	12.00
1 1/2	1.50	1.50	7.00	12.00	12.00	12.00
2 x 1 1/2	1.94	1.50	8.50	14.50	14.50	14.63
2 to 24	Please refer to T60S (p. 11)					

## Class 1500

unit: inch

SIZE (NPS)	d	d1	D	L		
				RF	WE	RJ
1/2	0.50	0.50	4.75	8.50	8.50	8.50
3/4 x 1/2	0.75	0.50	5.12	9.00	9.00	9.00
3/4	0.75	0.75	5.12	9.00	9.00	9.00
1 x 3/4	1.00	0.75	5.88	10.00	10.00	10.00
1	1.00	1.00	5.88	10.00	10.00	10.00
1 1/2 x 1	1.50	1.00	7.00	12.00	12.00	12.00
1 1/2	1.50	1.50	7.00	12.00	12.00	12.00
2 x 1 1/2	1.94	1.50	8.50	14.50	14.50	14.63
2 to 24	Please refer to T60S (p. 11)					

## Class 2500

unit: inch

SIZE (NPS)	d	d1	D	L		
				RF	WE	RJ
1/2	0.50	0.50	5.25	10.38	10.38	10.38
3/4 x 1/2	0.75	0.50	5.50	10.75	10.75	10.75
3/4	0.75	0.75	5.50	10.75	10.75	10.75
1 x 3/4	1.00	0.75	6.25	12.12	12.12	12.12
1	1.00	1.00	6.25	12.12	12.12	12.12
1 1/2 x 1	1.50	1.00	8.00	15.12	15.12	15.24
1 1/2	1.50	1.50	8.00	15.12	15.12	15.24
2 x 1 1/2	1.69	1.50	9.25	17.75	17.75	17.88
2	1.69	1.69	9.25	17.75	17.75	17.88
3 x 2	2.44	1.69	12.00	22.75	22.75	23.00
3	2.44	2.44	12.00	22.75	22.75	23.00
4 x 3	3.44	2.44	14.00	26.50	26.50	26.88
4	3.44	3.44	14.00	26.50	26.50	26.88
6 x 4	5.19	3.44	19.00	36.00	36.00	36.50
6	5.19	5.19	19.00	36.00	36.00	36.50
8 x 6	7.06	5.19	21.75	40.25	40.25	40.88
8	7.06	7.06	21.75	40.25	40.25	40.88

NOTE: PN designed valves can be available. Please ask product range and dimensions.

# Engineering Data

## Operating Torque

< Torque unit : N·m >

### Class 900

unit: N·m

Nominal Size	NPS	1/2	3/4	1	11/2	2	3	4	6	8	10	12
	DN	15	20	25	40	50	80	100	150	200	250	300
Differential Pressure (MPa)	0.5	24	30	42	79	*	*	*	*	*	*	*
	5	24	31	44	86	*	*	*	*	*	*	*
	7.5	26	34	48	94	*	*	*	*	*	*	*
	10	32	42	60	117	*	*	*	*	*	*	*
	12.5	38	50	71	140	*	*	*	*	*	*	*
	15	41	55	78	155	*	*	*	*	*	*	*

### Class 1500

unit: N·m

Nominal Size	NPS	1/2	3/4	1	11/2	2	3	4	6	8	10	12
	DN	15	20	25	40	50	80	100	150	200	250	300
Differential Pressure (MPa)	0.5	24	31	44	86	*	*	*	*	*	*	*
	5	24	31	44	86	*	*	*	*	*	*	*
	10	32	42	60	117	*	*	*	*	*	*	*
	15	41	55	78	155	*	*	*	*	*	*	*
	20	49	66	95	188	*	*	*	*	*	*	*
	25	56	76	109	216	*	*	*	*	*	*	*

### Class 2500

unit: N·m

Nominal Size	NPS	1/2	3/4	1	11/2	2	3	4	6
	DN	15	20	25	40	50	80	100	150
Differential Pressure (MPa)	0.5	32	39	59	105	131	190	333	901
	10	32	39	59	105	131	190	333	901
	20	40	50	75	141	171	263	475	1337
	30	51	64	95	185	221	349	639	1826
	40	60	77	113	223	265	425	783	2258
	42.5	68	88	128	256	303	491	908	2630

< Torque unit : inch-lbs >

### Class 900

unit: Inch-lbs

Nominal Size	NPS	1/2	3/4	1	11/2	2	3	4	6	8	10	12
	DN	15	20	25	40	50	80	100	150	200	250	300
Differential Pressure (PSIG)	100	217	278	392	757	*	*	*	*	*	*	*
	740	217	279	394	760	*	*	*	*	*	*	*
	1000	228	296	419	815	*	*	*	*	*	*	*
	1480	287	378	536	1053	*	*	*	*	*	*	*
	1800	332	439	625	1232	*	*	*	*	*	*	*
	2220	369	492	701	1385	*	*	*	*	*	*	*

### Class 1500

unit: Inch-lbs

Nominal Size	NPS	1/2	3/4	1	11/2	2	3	4	6	8	10	12
	DN	15	20	25	40	50	80	100	150	200	250	300
Differential Pressure (PSIG)	100	217	278	392	757	*	*	*	*	*	*	*
	740	218	280	395	763	*	*	*	*	*	*	*
	1480	286	377	535	1050	*	*	*	*	*	*	*
	2220	370	492	702	1387	*	*	*	*	*	*	*
	3000	446	598	854	1697	*	*	*	*	*	*	*
	3705	507	682	975	1942	*	*	*	*	*	*	*

### Class 2500

unit: Inch-lbs

Nominal Size	NPS	1/2	3/4	1	11/2	2	3	4	6
	DN	15	20	25	40	50	80	100	150
Differential Pressure (PSIG)	100	287	346	525	927	1160	1681	2950	7971
	1480	288	348	527	934	1167	1694	2976	8050
	3000	363	453	673	1273	1543	2380	4306	12126
	4300	447	566	834	1620	1941	3064	5607	16013
	5800	532	681	997	1974	2346	3762	6932	19979
	6170	604	778	1134	2272	2686	4351	8053	23336

#### NOTES

- (1) Please refer to p. 23-24 for Class 150 to 600 and \* torque values.
- (2) All torque values include a 30% safety factor. Values are for clean, static water at ambient temperature.
- (3) Ball seat material: RNYlon
- (4) In case of using higher safety factor than 30%, please confirm the maximum allowable stem strength.

# Engineering Data

## Flow Coefficient (Cv)

Nominal Size		NPS	1/2	3/4	1	1 1/2	2	3	4	6	8	10	12	14
		DN	15	20	25	40	50	80	100	150	200	250	300	350
Class	150		20	40	85	260	*	*	*	*	*	*	*	*
	300		20	40	85	250	*	*	*	*	*	*	*	*
	600		20	38	65	230	*	*	*	*	*	*	*	*
	900		15	35	60	165	*	*	*	*	*	*	*	*
	1500		15	35	60	165	*	*	*	*	*	*	*	*
	2500		15	30	55	150	250	500	1050	2500	5200	-	-	-

Nominal Size		NPS	16	18	20	22	24	26	28	30	32	34	36
		DN	400	450	500	550	600	650	700	750	800	850	900
Class	150		*	*	*	*	*	130000	152000	179000	202000	230000	258000
	300		*	*	*	*	*	124000	146000	172000	192000	219000	243000
	600		*	*	*	*	*	115000	135000	159000	177000	200000	220000
	900		*	*	*	-	*	-	-	-	-	-	-
	1500		*	*	*	-	*	-	-	-	-	-	-
	2500		-	-	-	-	-	-	-	-	-	-	-

NOTE: \* Please refer to p. 23.

## Weight

< weight unit : kg >

Nominal Size		NPS	1/2	3/4	1	1 1/2	2	3	4	6	8	10	12
		DN	15	20	25	40	50	80	100	150	200	250	300
Class	900		14	17	20	38	*	*	*	*	*	*	*
	1500		14	17	20	38	*	*	*	*	*	*	*
	2500		-	-	-	67	110	220	405	1060	-	-	-

unit : kg

< weight unit : lb >

Nominal Size		NPS	1/2	3/4	1	1 1/2	2	3	4	6	8	10	12
		DN	15	20	25	40	50	80	100	150	200	250	300
Class	900		31	38	44	84	*	*	*	*	*	*	*
	1500		31	38	44	84	*	*	*	*	*	*	*
	2500		-	-	-	148	243	485	893	2337	-	-	-

unit : lb

NOTE: These tables show raised face flanged and bare stem valves.

\* Please refer to p. 24.

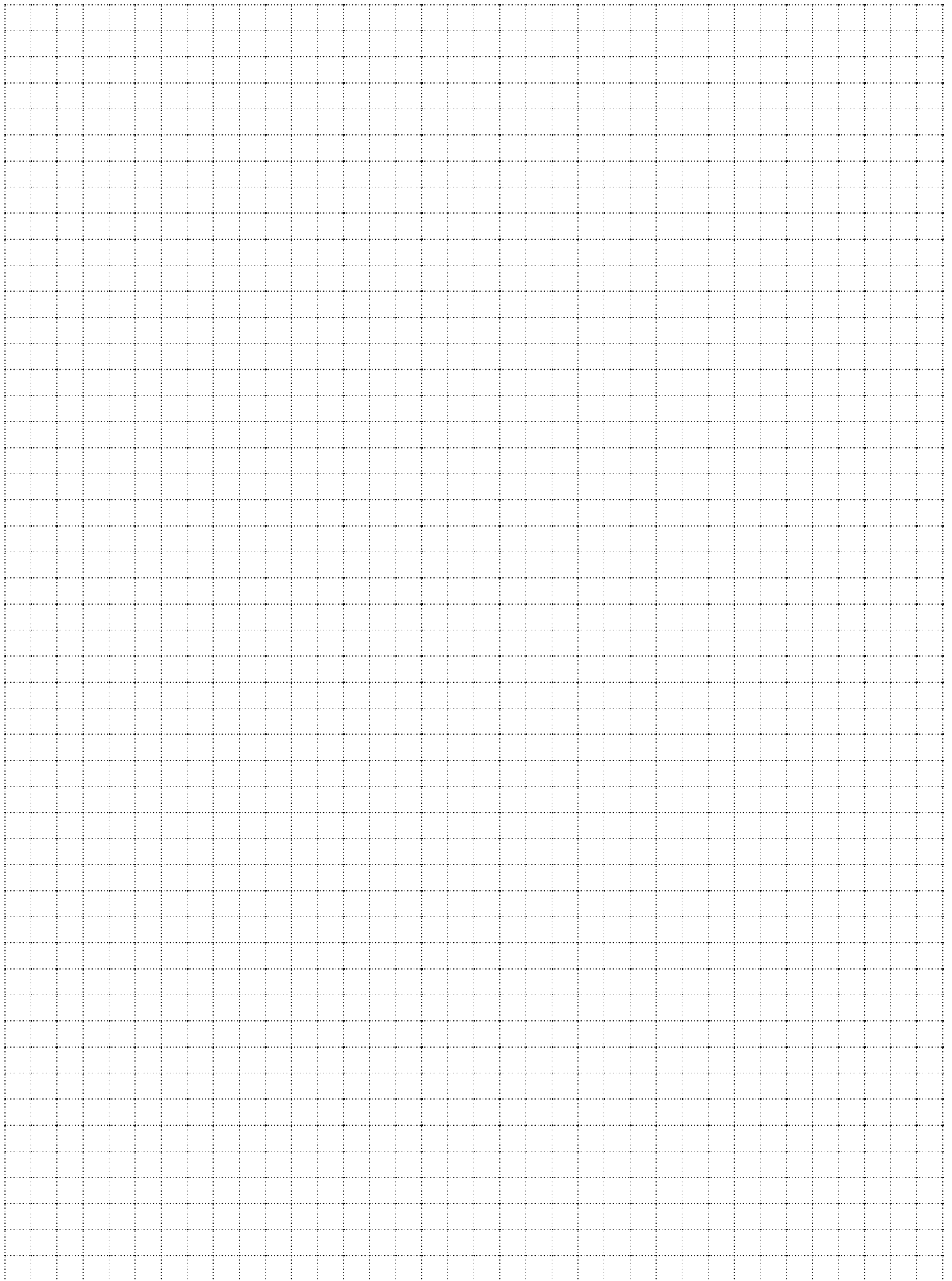

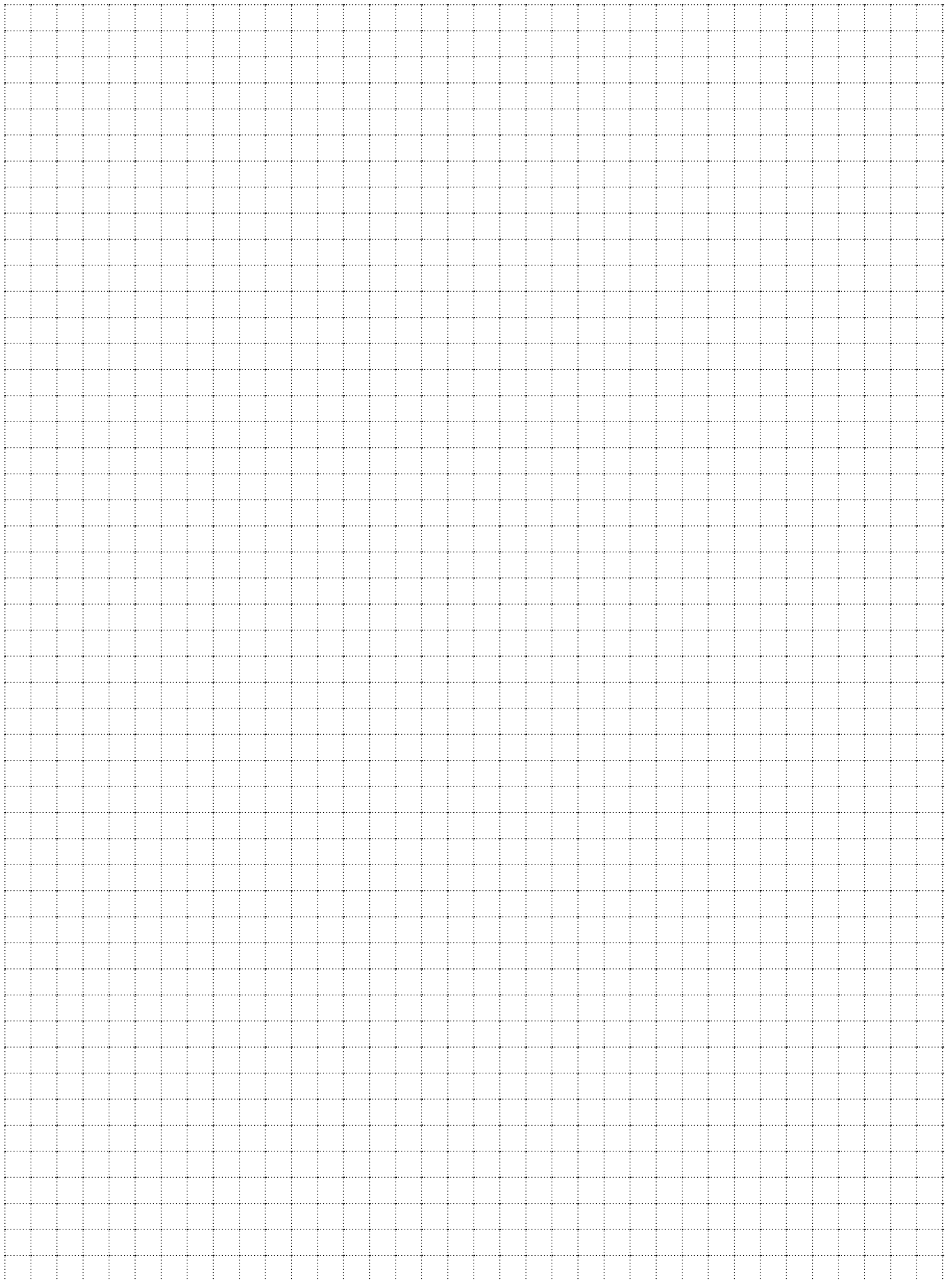

## CAUTION

Pressure-temperature ratings and other performance data published in this catalog have been developed from our design calculation, in-house testing, field reports provided by our customers, and/or published official standards or specifications. They are good only to cover typical applications as a general guideline to users of KITZ products introduced in this catalog.

KITZ Carbon Steel Paintings are suitable for general service conditions. For painting used in severe atmospheres or at elevated temperatures. Please contact us for recommendations based on your service environment.

For any specific application, users are kindly requested to contact KITZ Corporation for technical advice, or to carry out their own study and evaluation for proving the suitability of these products to such an application. Failure to follow this request could result in property damage and / or personal injury, for which we shall not be liable.

While this catalog has been compiled with the utmost care, we assume no responsibility for errors, impropriety, or inadequacy. Any information provided in this catalog is subject to from-time-to-time change without notice for error rectification, product discontinuation, design modification, new product introduction, or any other cause that KITZ Corporation considers necessary. This edition cancels all previous issues.

Read the instruction manual carefully before use.

## NOTICE

If any products designated as strategic material in the Foreign Exchange and Foreign Trade Law, Cabinet Order Concerning Control of Export Trade, Cabinet order Concerning Control of Foreign Exchange, and other related laws and ordinances ("Foreign Exchange Laws") are exported to any foreign country or countries, an export license issued by the Japanese Government will be required under the Foreign Exchange Laws.

Further, there may be cases where an export license issued by the government of the United States or other country will be required under the applicable export-related laws and ordinances in such relevant countries.

The contract shall become effective subject to the fact that a relevant export license is obtained from the Japanese Government.

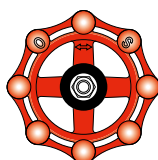

*A chrysanthemum-handle is a symbol of KITZ,  
the brand of valve reliability*

ISO 9001 certified since 1989

**KITZ**  
KITZ CORPORATION

1-10-1 Nakase, Mihama-ku, Chiba 261-8577, Japan  
International Sales Dept.  
Phone : 81-43-299-1730  
Fax : 81-43-299-0121

— Distributed by —

