

Features of KITZ F Series Pneumatic Actuators

Type FA (Double-Action)

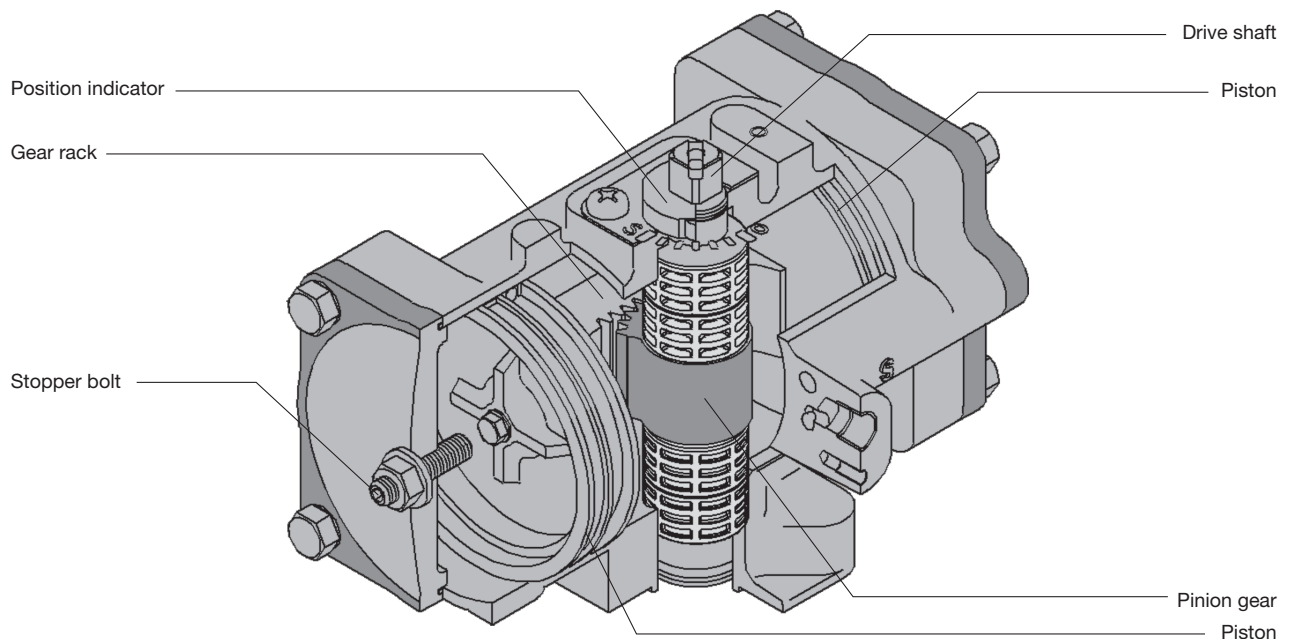

Featured by the utmost handling ease and extended service life with high operational efficiency

Easy answers to engineering modification requirements

- Position indicator can be adjusted by 90°, when actuator mounting position is turned by 90°, for local piping or operating convenience.
- Actuator shaft rotating angle (valve opening/closing range) can be adjusted with optional longer stopper bolt to full 90° rotation for plus/minus 7°.
- Standard AIR-FAIL-CLOSE mode can be converted to AIR-FAIL-OPEN mode by means of mounting of spring cartridge on the actuator housing reverse end. (spring-return type only)
- Replacing modular units of blowoff-proof spring cartridge enables accommodation of higher output torque or lower operating pressure. (spring-return type only)
- Valve actuation mode is convertible between double-action and spring-return with addition or deletion of spring cartridge.

Economic advantage

Use of monobloc casting of piston-rack assembly results in reduced housing dimensions by 10% to 15% (compared with KITZ D Series actuators), and

saves air consumption for valve actuation.

Extended service life with monobloc casting of two pistons and a gear-rack

Pitch line of a gear-rack is positioned in the center of actuator housing, and two pistons are cast in integration with gear-rack as one-piece unit. This helps to keep piston position in parallel during actuator travel.

Light and compact housing

Employment of diecast aluminum for housings and piston-rack assemblies has reduced the actuator weight by 20% to 40% (compared with KITZ D Series actuators) for better torque-to-weight ratio.

Conformity to international standards

NAMUR VDI/VDE 3845 designs are used for tubeless mounting of solenoid valve and switchbox on actuator housing besides the conformity to ISO 5211 requirements for valve mounting flanges. The stem top design also conforms to NAMUR dimensions.

Actuators can be directly mounted to KITZ DJ, XJ Series Butterfly Valves

Optional adaptors (connectors) to the valves on the bottom of actuators can be provided for wide mounting variations

Type FAS (Spring-Return)

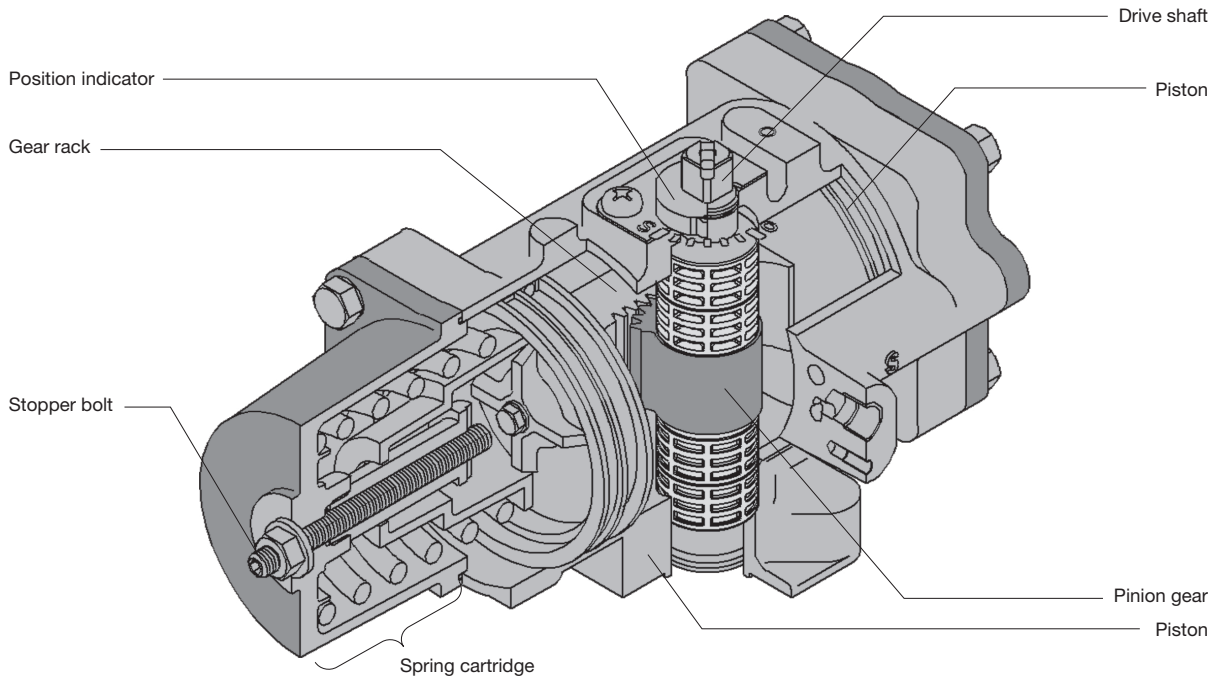

Actuator Output Torque

Double-action

unit : N·m

Type	Operating pressure (air) 0.4 MPa	
	FA-1	19.2
FA-2	45.4	
FA-3	91.6	
FA-4	182	
FA-5	338	
FA-6	800	

Spring-return

unit : N·m

Type	Operating pressure (air) 0.4 MPa		Operating force (Spring)	
	0°	90°	0°	90°
FAS-1	12.1	8.0	7.6	11.7
FAS-2	27.5	19.1	18.0	26.3
FAS-3	55.3	37.3	35.2	53.1
FAS-4	111.0	75.7	74.7	110.0
FAS-5	206.0	140.0	137.0	203.0
FAS-6	487.0	325.0	319.0	481.0

Specifications and Dimensions

Operating medium	: Compressed instrument air or nitrogen gas
Operating pressure	: Standard operating pressure 0.4 MPa
Operating pressure range	: 0.3 MPa to 0.7 MPa *
Cylinder test pressure	: 0.97 MPa
Shaft rotating angle	: $90^{\circ} \pm 7^{\circ}$
Service temperature	: -20°C to $+80^{\circ}\text{C}$ (Supplied air should not be frozen.)
Opening degree indication	: Indicator has 15 degree graduation (0 to 90°)
Valve mounting flange	: ISO 5211
Accessory mounting connection	: NAMUR VDI/VDE 3845
Coating	: Baked Polyester Resin Coating

* Be consulted by KITZ for non-standard operating pressure.

Type FA (Double-action)

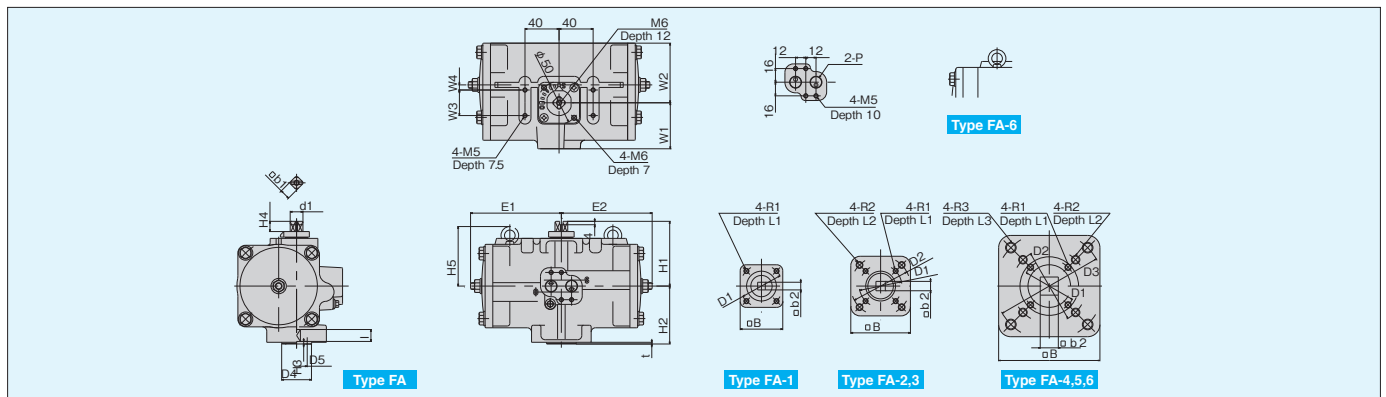

Type FA Dimensions

unit : mm

Type	E ₁	E ₂	W ₁	W ₂	W ₃	W ₄	H ₁	H ₂	H ₃	H ₄	H ₅	D ₁	D ₂	D ₃	D ₄	D ₅	d ₁	b ₁	b ₂	B	ℓ	t	R ₁ ×L ₁	R ₂ ×L ₂	R ₃ ×L ₃	P
FA-1	87	87	50	54	30	0	70	55	3	12	—	50	—	—	35	25	15	12	9	50	16	2	M6 × 9	—	—	BSPT1/4
FA-2	107	107	54	70	30	6	80	68	3	12	—	50	70	—	35	30	15	12	11	70	16	2	M6 × 9	M8 × 12	—	BSPT1/4
FA-3	128	128	57	87	30	13	86	78	3	12	—	50	70	—	35	32	21	17	13	70	25	2	M6 × 9	M8 × 12	—	BSPT1/4
FA-4	160	160	68	111	30	21	108	96	4	12	—	50	70	102	55	40	21	17	17	95	27	3	M6 × 9	M8 × 12	M10×15	BSPT1/4
FA-5	208	208	78	135	30	30	132	116	5	20	—	70	102	125	55	50	29	23	27	113	34	3	M8×12	M10×15	M12×18	BSPT1/4
FA-6	268	268	101	178	30	45	152	125	5	20	157	70	102	125	70	60	41	32	27	134	34	3	M8×12	M10×15	M12×18	BSPT1/4

Type FAS (Spring-return)

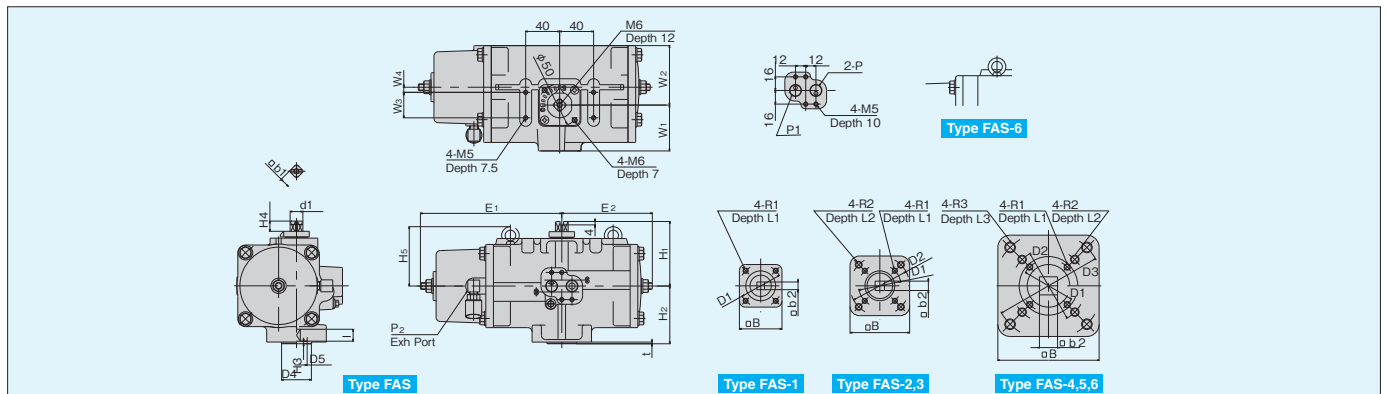

Type FAS Dimensions

unit : mm

Type	E ₁	E ₂	W ₁	W ₂	W ₃	W ₄	H ₁	H ₂	H ₃	H ₄	H ₅	D ₁	D ₂	D ₃	D ₄	D ₅	d ₁	b ₁	b ₂	B	ℓ	t	R ₁ ×L ₁	R ₂ ×L ₂	R ₃ ×L ₃	P1	P2
FAS-1	132	87	50	54	30	0	70	55	3	12	—	50	—	—	35	25	15	12	9	50	16	2	M6 × 9	—	—	BSPT1/4	BSPT $\frac{1}{8}$
FAS-2	166	107	54	70	30	6	80	68	3	12	—	50	70	—	35	30	15	12	11	70	16	2	M6 × 9	M8 × 12	—	BSPT1/4	BSPT $\frac{1}{8}$
FAS-3	203	128	57	87	30	13	86	78	3	12	—	50	70	—	35	32	21	17	13	70	25	2	M6 × 9	M8 × 12	—	BSPT1/4	BSPT $\frac{1}{8}$
FAS-4	290	160	68	111	30	21	108	96	4	12	—	50	70	102	55	40	21	17	17	95	27	3	M6 × 9	M8 × 12	M10×15	BSPT1/4	BSPT $\frac{1}{8}$
FAS-5	363	208	78	135	30	30	132	116	5	20	—	70	102	125	55	50	29	23	27	113	34	3	M8×12	M10×15	M12×18	BSPT1/4	BSPT $\frac{1}{8}$
FAS-6	483	268	101	178	30	45	152	125	5	20	157	70	102	125	70	60	41	32	27	134	34	3	M8×12	M10×15	M12×18	BSPT1/4	BSPT $\frac{1}{8}$

Operating Mechanism

Type FA (Double-action)

- (1) Air pressure supplied into the chamber **A** through port ①, pushes gear rack with two pistons outward, and discharges the air residue (chamber **B**) through port ②.
- (2) The gear rack rotates the pinion gear and the shaft counter-clockwise, to drive the valve.
- (3) Reverse supply of the air pressure activates reverse valve operation.

Type FAS (Spring-return)

- (1) Air pressure supplied into the chamber **A** through port ①, pushes gear rack with two pistons outward, compresses the spring and discharges the air residue through port ②.
- (2) The gear rack rotates the pinion gear and the shaft counter-clockwise, to drive the valve.
- (3) At the moment the air in the chamber **A** is discharged through the solenoid valve, the spring force pushes the pistons to the reverse direction, and the gear rack activates rotation of the shaft clockwise to reversely operate the valve.

Cylinder volume

unit : ℓ

Type	Chamber A	Chamber B
FA-1	0.15	0.15
FA-2	0.31	0.31
FA-3	0.61	0.61
FA-4	1.29	1.29
FA-5	2.29	2.29
FA-6	5.27	5.27

Cylinder volume

unit : ℓ

Type	Chamber A
FAS-1	0.15
FAS-2	0.31
FAS-3	0.61
FAS-4	1.29
FAS-5	2.29
FAS-6	5.27

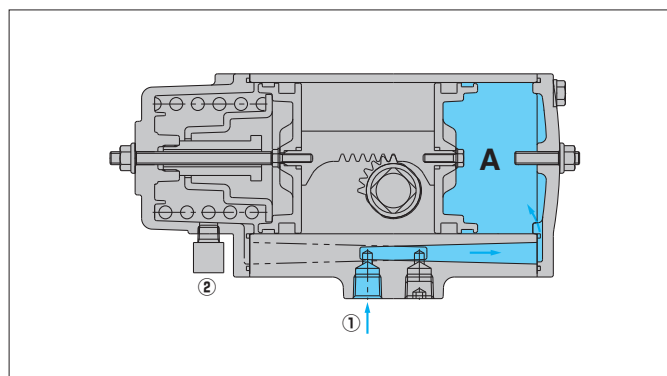
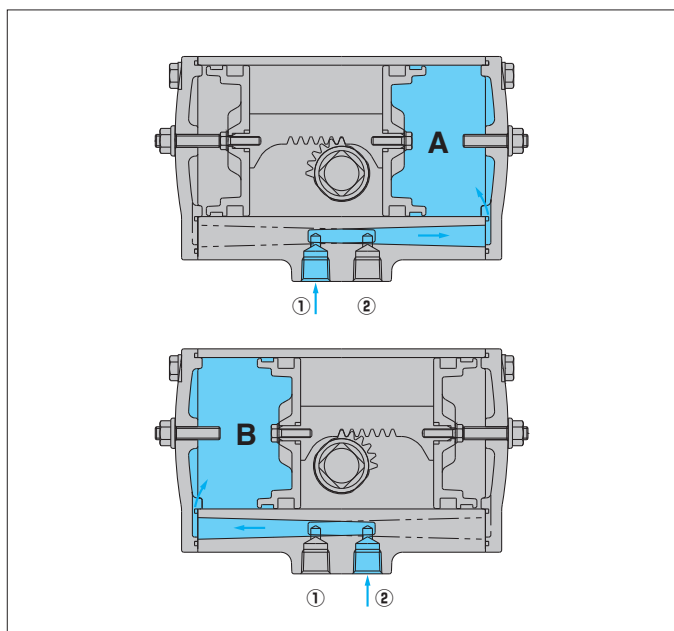

Actuator Sizing

The sizing shown below is based on the following conditions.

Ball valves

Operating pressure	0.4 MPa
Fluid type	· Fresh water or lubricant, Max. 1.0 MPa (* The figures shown in the table indicate service pressure limit. Unit MPa) · Air gas or steam, Max. 0.7 MPa
Fluid temperature	-20°C to +230°C (Limited within seat rating)

Be consulted by KITZ, if:

- ① Valves handle
 - a. Solvents, such as kerosene, naphtha or alcohol.
 - b. Powder, slurry or dehydrated cake.
 - c. Vacuum or any other service requiring oil free treatment.
- ② Valves are not operated for more than 3 months.
- ③ Valves are used as a control valve.

Butterfly valves

Operating pressure	0.4 MPa
Fluid type	Smooth fluid · Fresh water, lubricant (Max 1,000 cp)
Velocity	Up to 2 m/sec
Fluid temperature	0°C to Max. working temperature

Type, temperature and pressure of the fluid shall be determined by the rubber seat. Valve selection must properly be made based on these conditions.

Extra care shall be taken on velocity, if valves are used at the pump exit.

Type FA (Double-action)

Type	Bore	Shell Material	Class	Conection	Product coding	Size																				
						A	10	15	20	25	32	40	50	65	80	100	125	150	200	250	300					
						B	3/8	1/2	3/4	1	1 1/4	1 1/2	2	2 1/2	3	4	5	6	8	10	12					
Ball Valve	Full Bore	Cast Iron	JIS 10K	Threaded	10FCT																					
				Flanged	10FCTB																					
		Ductile Iron	JIS 10K	Flanged	10STBF																					
					Threaded	10UT																				
		Stainless Steel	JIS 10K Class 150	Flanged	10/150UTB, 10/150UTDZ																					
					20/300UTB, 20/300UTDZ																					
			Carbon Steel	JIS 10K Class 150	Flanged	10/150SCTDZ																				
						JIS 20K Class 300	20/300SCTDZ																			
	Reduced Bore	Stainless Steel	JIS 10K Class 150	Flanged	10UTR · 150UTR																					
					JIS 20K Class 300	20UTR · 300UTR																				
		Carbon Steel	Class 150	Flanged	150SCTR																					
					Class 300	300SCTR																				
	Full Bore (3 way)	Stainless Steel	JIS 10K	Flanged	10UTB4T (L) A																					
					Full Bore (PFA Lining)	10UTBLN																				
Butterfly Valve	Aluminum	JIS 10K	Wafer	10XJME																						
				10XJSME																						
	Ductile Iron	JIS 16K BS PN16	Wafer	10DJ																						
				16DJ, PN16DJ																						

*FA-5 for TDZ.

Actuator Sizing

Type FAS (Spring-Return)

Type	Bore	Shell Material	Class	Conection	Size Product coding	A	10	15	20	25	32	40	50	65	80	100	125	150	200	250	300		
						B	3/8	1/2	3/4	1	1 1/4	1 1/2	2	2 1/2	3	4	5	6	8	10	12		
Ball Valve	Full Bore	Cast Iron	JIS 10K	Threaded	10FCT																		
				Flanged	10FCTB																		
		Ductile Iron	JIS 10K	Flanged	10STBF																		
					Threaded	10UT																	
		Stainless Steel	JIS 10K Class 150	Flanged	10/150UTB, 10/150UTDZ		FAS-1				FAS-2		FAS-3		FAS-4		FAS-5		FAS-6				
					20/300UTB, 20/300UTDZ									*									
	Carbon Steel		JIS 10K Class 150	Flanged	10/150SCTDZ																		
					JIS 20K Class 300	20/300SCTDZ									*								
	Reduced Bore	Stainless Steel	JIS 10K Class 150	Flanged	10UTR · 150UTR								FAS-3									FAS-6	
					JIS 20K Class 300	20UTR · 300UTR																	
		Carbon Steel	Class 150	Flanged	150SCTR																		FAS-5
					Class 300	300SCTR																	
Full Bore (3 way)	Stainless Steel	JIS 10K	Flanged	10UTB4T (L) A		FAS-2		FAS-3		FAS-4	FAS-5	FAS-6											
Full Bore (PFA Lining)				10UTBLN		FAS-1	FAS-2		FAS-3	FAS-4	FAS-5												
Butterfly Valve	Aluminum	JIS 10K	Wafer	10XJME								FAS-2		FAS-3		FAS-4	FAS-5	FAS-6					
				10XJSME																			
	Ductile Iron	JIS 16K BS PN16	Wafer	10DJ																			
				16DJ, PN16DJ																			

Note : The standard combination of UTDZ/SCTDZ size 20^A (3/4^B) is FAS-2

*FAS-5 for TDZ.

Construction Details

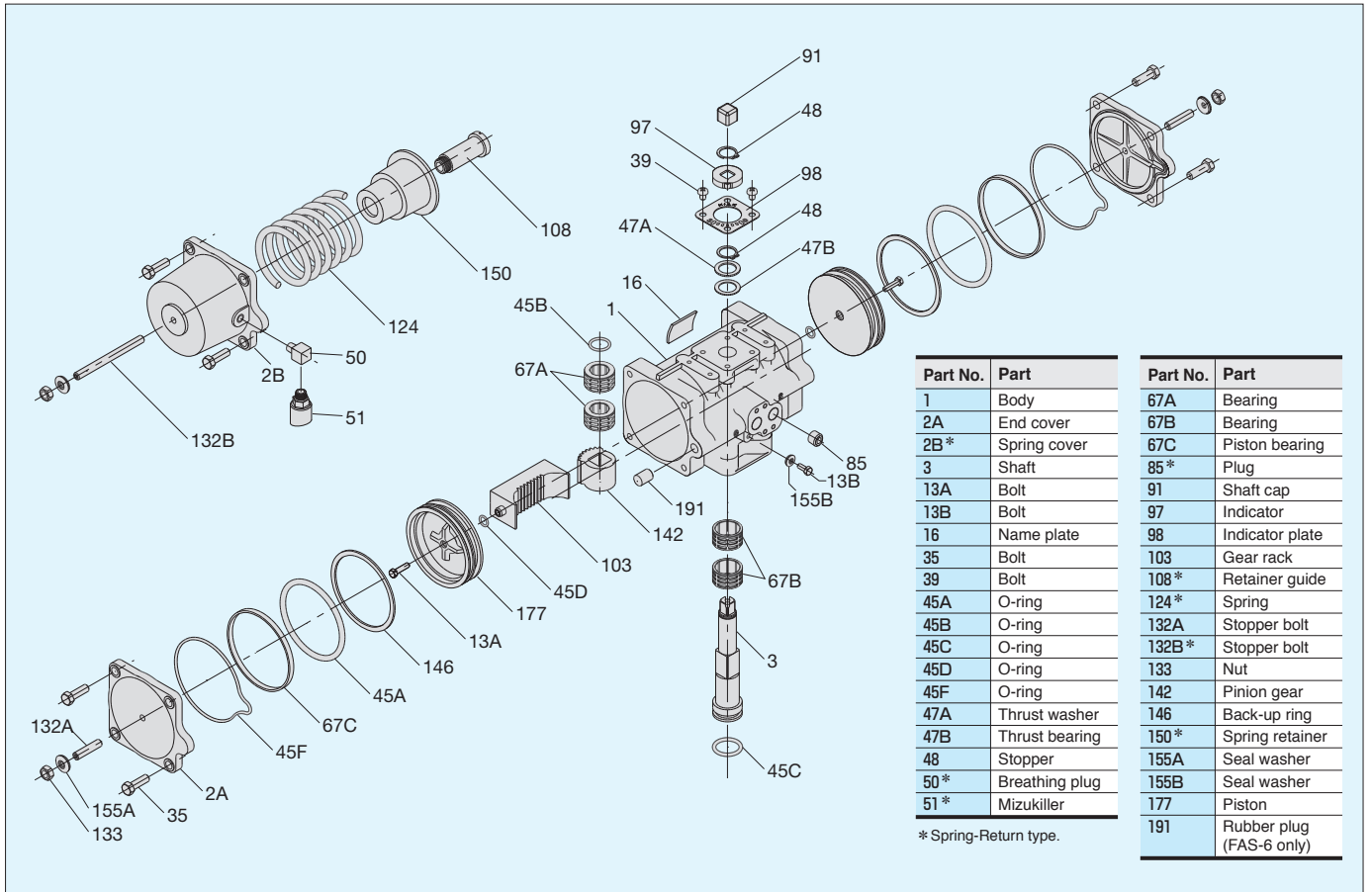

Optional Accessories

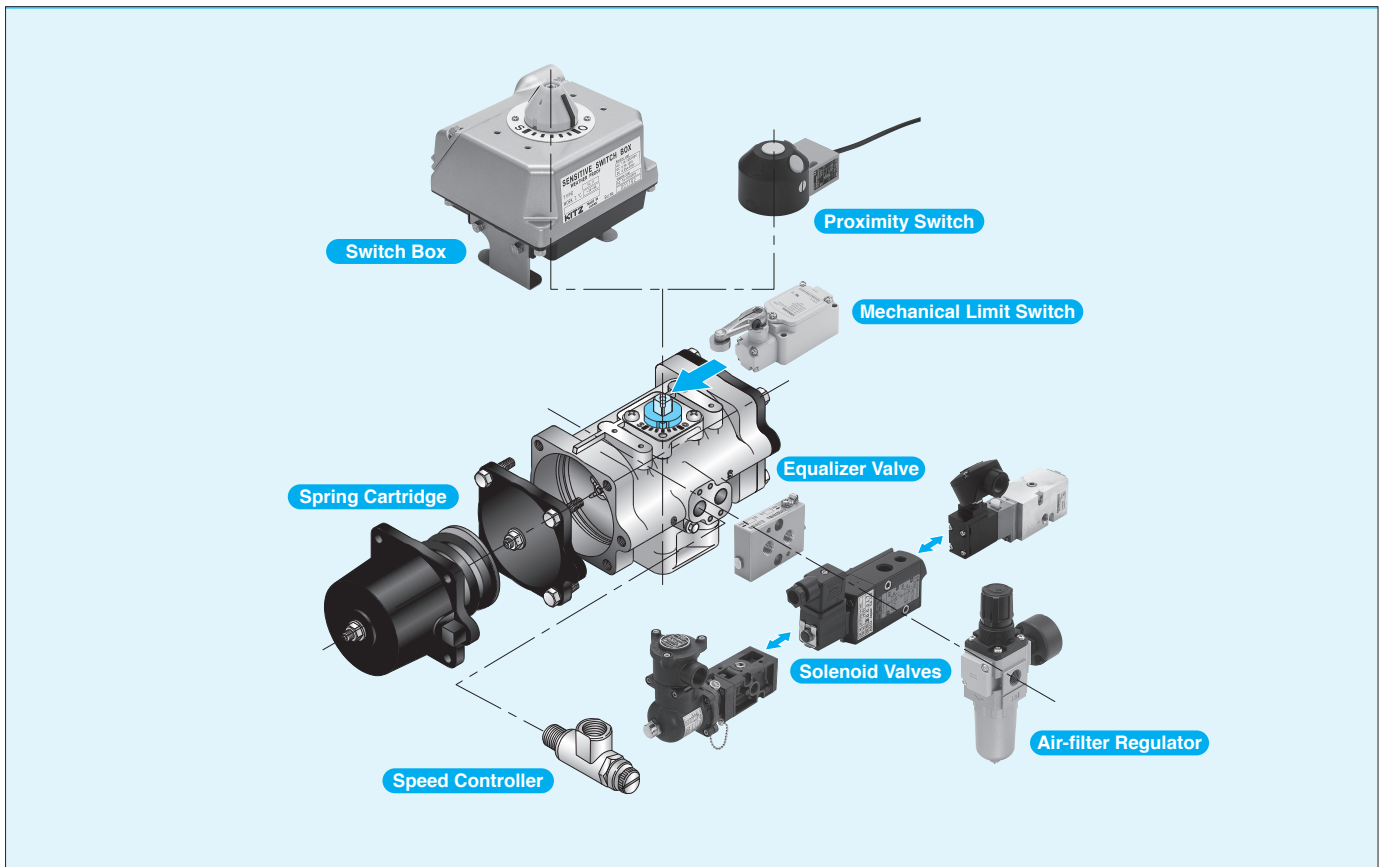

Valve and Actuator Handling Instructions

1. Before installing valves on pipelines, remove welding chips, scales and other foreign objects from the ports; flush the insides thoroughly.
2. Both pneumatically operated ball and butterfly valves can be installed horizontally or vertically. Fluid can be discharged from either port. However, air filters and lubricators attached to actuators should be correctly positioned in consideration of the weight of actuators which may cause an extra stress on the pipeline.
3. For convenience of maintenance service, provide an adequate space around valves, such as 300 mm above, 500 mm below, and 300 mm wide from the sides.
4. Ambient temperatures allowable for actuators ranges between -20°C and $+60^{\circ}\text{C}$. Valves should be adequately protected if the ambient temperature exceeds this range.
5. If a pipeline vibrates, take appropriate prevention measures.
6. In corrosive atmospheres such as SO_2 or Cl_2 , corrosive gas should not be intruded into the air supply.
7. Use air compressors and air reservoirs with a capacity of 130% of the piping capacity and air consumption.
The maximum supply air pressure for KITZ B Series actuators is 0.7 MPa (or 100 psi).
8. During the initial operation, or after suspension of operation exceeding 3 month, operating torque may exceed the specified level. In these cases, actuators should be manually operated several times before starting pneumatic activation.

Precautions

CAUTION

- Ensure to read and follow instructions of operation manual when handling F Series actuators.
- Ensure to select F Series actuators in consideration of specifications of this catalog.
- Refer to the valve catalogs for detailed specifications of the valves to mount actuators.
- Cylinder bodies of double-action type and spring-return type are interchangeable. Double-action type can be converted to spring return type by changing spring cartridge.
- Actuator sizing may differ for the particular service conditions when converting double-action type to spring-return type. Contact KITZ Corporation for proper sizing.
- Standard operating pressure built-in spring return type is 4K. (0.4 to 0.7 MPa)
- Spring cartridge with different operating pressures 3K (0.3 to 0.7 MPa) and 5K (0.5 to 0.7 MPa) is optionally available. Contact KITZ Corporation for actuator sizing of 3K and 5K types.
- Do not use excessive operating pressures to actuators, which will damage internal parts and result in malfunction.
- Ensure to use compressed instrumentation air or nitrogen gas as operating medium.
- It will damage internal and external parts to use actuators under corrosive environments.
 1. Holding valve position
KITZ pneumatic actuators do not assure no leakage. Actuators do not hold valve positions long time without continuous air supply. If you need to hold valve position long time without continuous air supply, contact KITZ Corporation or its distributors.
 2. Internal air residue of spring-return type actuators
Output torques of spring-return type actuators indicate valves without internal air residue remains inside their cylinders. Please design your systems to be able to exhaust internal air residue at spring-return action. If internal air residue remains in the cylinders, the output torque will be small and valves do not open or close by spring-return action.
- Air supply inlet threads are BSPT $\frac{1}{4}$ as standard. Ensure to use piping tubes which diameters are $\phi 6$ and smaller. Contact KITZ Corporation to reduce operating time with larger diameter piping tube.
- It is recommended to use KITZ standard accessories for F Series actuators.

CAUTION

- Ensure to select solenoid valves suitable for the service conditions.
- Specify piping positions when using actuated valves with positioners since piping positions may make opening slip.
- A part to avoid water to enter into a spring case (“Mizukiller”) is installed on spring-return type actuator’s breathing port. And the Mizukiller is sealed with a sticker. Remove the sticker before running automated operation.
(For products shipped before December 2009, a cap is installed on spring-return type actuator’s breathing port instead of the Mizukiller. Remove the cap before running automated operation. If the cap remains, actuator speed may become slow.)
- When Type FAS spring-return actuator is used outside or in wet condition, the Mizukiller has to be installed into it. If the Mizukiller is not installed, water may enter into a spring cartridge and cause a malfunction.

WARNING

- Spring cartridge for spring-return type has strongly compressed built-in spring. Careful handling of spring cartridge is required to avoid its blowing out. Do not loosen stopper bolt of spring cartridge.
- Do not remove end covers and spring covers or disassemble actuators while they are pressurized.

DISCLAIMER

- KITZ does not take any responsibilities for damages arising from a result of natural disasters, accidents or fire which KITZ is not liable for, conduct of a third party, intentional act, misuse or use under abnormal conditions by a customer.
- KITZ does not take any responsibilities for damages arising from negligence of the prohibitions and cautions given in the catalogs and operation manuals, or installation and usage beyond the specification range.
- KITZ does not take any responsibilities for damages arising from product modification not entrusted to KITZ or usage under the load applied from other devices.

CAUTION

Pressure-temperature ratings and other performance data published in this catalog have been developed from our design calculation, in-house testing, field reports provided by our customers and/or published official standards or specifications. They are good only to cover typical applications as a general guideline to users of KITZ products introduced in this catalog.

For any specific application, users are kindly requested to contact KITZ Corporation for technical advice, or to carry out their own study and evaluation for proving suitability of these products to such an application. Failure to follow this request could result in property damage and/or personal injury, for which we shall not be liable.

While this catalog has been compiled with the utmost care, we assume no responsibility for errors, impropriety or inadequacy. Any information provided in this catalog is subject to from-time-to-time change without notice for error rectification, product discontinuation, design modification, new product introduction or any other cause that KITZ Corporation considers necessary. This edition cancels all previous issues.

Read instruction manual carefully before use.

NOTICE

If any products designated as strategic material in the Foreign Exchange and Foreign Trade Law, Cabinet Order Concerning Control of Export Trade, Cabinet order Concerning Control of Foreign Exchange and other related laws and ordinances ("Foreign Exchange Laws") are exported to any foreign country or countries, an export license issued by the Japanese Government will be required under the Foreign Exchange Laws.

Further, there may be cases where an export license issued by the government of the United States or other country will be required under the applicable export-related laws and ordinances in such relevant countries.

The contract shall become effective subject to that a relevant export license is obtained from the Japanese Government.

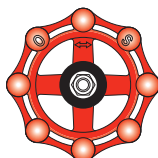

*A chrysanthemum-handle is a symbol of KITZ,
the brand of valve reliability*

ISO 9001 certified since 1989

KITZ
KITZ CORPORATION

1-10-1 Nakase, Mihama-ku, Chiba 261-8577, Japan
International Sales Dept.
Phone : 81-43-299-1730
Fax : 81-43-299-0121

— Distributed by —

