

- **Globe valves** ▪ **Globe valve** ▪ **200 AE/BE/AJ/BJ** ▪ **PN 10-160** ▪ **DN 10-50**
- **Globe valves** ▪ **Lift check valve** ▪ **240 MT** ▪ **PN 10-160** ▪ **DN 10-50**

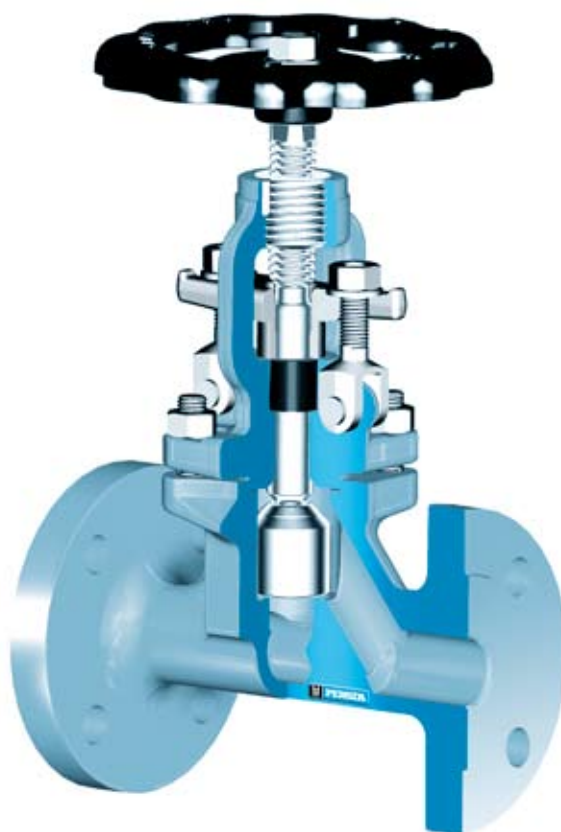

### Range of application

Admissible operating pressure [bar] at design temperature [°C] <sup>1)</sup>

Material	PN	Admissible operating pressure [bar] at design temperature [°C] <sup>1)</sup>																	
		-200	-60	-10	20	120	150	200	250	300	350	400	450	500	510	520	530	540	550
<b>1.0460</b>	<b>10-40</b>			40	40	40	37	35	32	28	24	21	10						
	<b>63</b>	63	63	63	58	50	45	40	36	32	24								
	<b>100</b>	100	100	100	90	80	70	60	56	50	38								
	<b>160</b>	160	160	160	145	130	112	96	90	80	60								
<b>1.5415</b> <sup>5)</sup>	<b>10-40</b>			40	40	40	40	40	35	31	30	28	18	14	11	9			
	<b>63</b>	63	63	63	63	63	63	56	50	47	45	29	22	16	14				
	<b>100</b>	100	100	100	100	100	100	87	78	74	70	45	34	27	22				
	<b>160</b>	160	160	160	160	160	160	139	125	118	112	72	55	43	35				
<b>1.7335</b>	<b>10-40</b>			40	40	40	40	40	40	38	36	34	29	24	19	15	12	9	
	<b>63</b>	63	63	63	63	63	63	63	61	58	56	47	40	32	25	20	15		
	<b>100</b>	100	100	100	100	100	100	100	95	91	87	74	62	49	38	31	24		
	<b>160</b>	160	160	160	160	160	160	160	153	146	139	118	100	79	62	46	35		
<b>1.4571</b>	<b>10-40</b> <sup>2)3)4)</sup>	40	40	40	40	40	40	40	38	36	34	32	32	32	31	31	31	31	
	<b>63</b> <sup>2)3)4)</sup>	63	63	63	63	63	59	56	53	50	48	47							
	<b>100</b> <sup>2)3)4)</sup>	100	100	100	100	100	92	88	83	79	76	73							
	<b>160</b> <sup>2)3)4)</sup>	160	160	160	160	160	150	142	135	127	123	119							
<b>1.0566</b>	<b>10-40</b> <sup>4)6)</sup>		40	40	40	37	35	32	28										
	<b>63</b> <sup>4)6)</sup>		63	63	63	58	50	45	40										
	<b>100</b> <sup>4)6)</sup>		100	100	100	92	80	70	60										
	<b>160</b> <sup>4)6)</sup>		160	160	160	147	130	112	96										

1) Operating temperature = design temperature minus temperature surcharge acc. to DIN regulations.  
 2) Application at more than 400 °C operating temperature only admissible if no intercrystalline corrosion has to be expected.  
 3) At operating temperature 400 °C the material of the screws is 1.4986.  
 4) In case of screws A4-70 with > 8 x d screw-length the mechanical strength properties acc. to table 6 of DIN 267 Part 11 have been considered.  
 5) Butt welding ends  
 6) At temperature > 50 °C only applicable for short-time service.

- **Globe valves** ▪ **Globe valve** ▪ **200 AE/BE/AJ/BJ** ▪ **PN 10-160** ▪ **DN 10-50**
- **Globe valves** ▪ **Lift check valve** ▪ **240 MT** ▪ **PN 10-160** ▪ **DN 10-50**

#### Standard features

- Straight body
- Die-forged valve body and bonnet
- Shut-off disc, Fig. No. 200 AE
- Shut-off disc with yoke sleeve, standard features AJ
- Trottle disc with yoke sleeve, standard features BJ
- Trottle disc standard features BE
- Outside screw and yoke
- Position indicator if required
- Turning and rising stem (AE/BE)
- Non-turning, rising stem (AJ/BJ)

#### Pressure and temperature ratings

- Pressure rating BW-Ends up to 160 bar
- Pressure rating FL up to 160 bar
- Temperature rating up to 550 °C

#### Materials

- 1.0460
- 1.0566
- 1.5415 only with BW-Ends
- 1.7335
- 1.4571

Further materials on request.

#### Media

Depending on the material the valves are suitable for water, gas, oil and other non aggressive media

#### Fields of application

Chemical industries, power plants, ship building and other

#### Design Highlights

- Die-forged valve body and bonnet
- Seats are hardfaced or welded on
- Body-bonnet connection male and female
- Body and bonnet in two separate pieces with bolted connection

#### Benefits

- Free from porosity and shrink holes
- Extremely resistant to wear
- Sealing blow out proof
- To ease maintenance work, e.g. regrinding of the body seats

- **Globe valves** ▪ **Globe valve** ▪ **200 AE/BE/AJ/BJ** ▪ **PN 10-160** ▪ **DN 10-50**
- **Globe valves** ▪ **Lift check valve** ▪ **240 MT** ▪ **PN 10-160** ▪ **DN 10-50**

**Globe valve AE/BE**

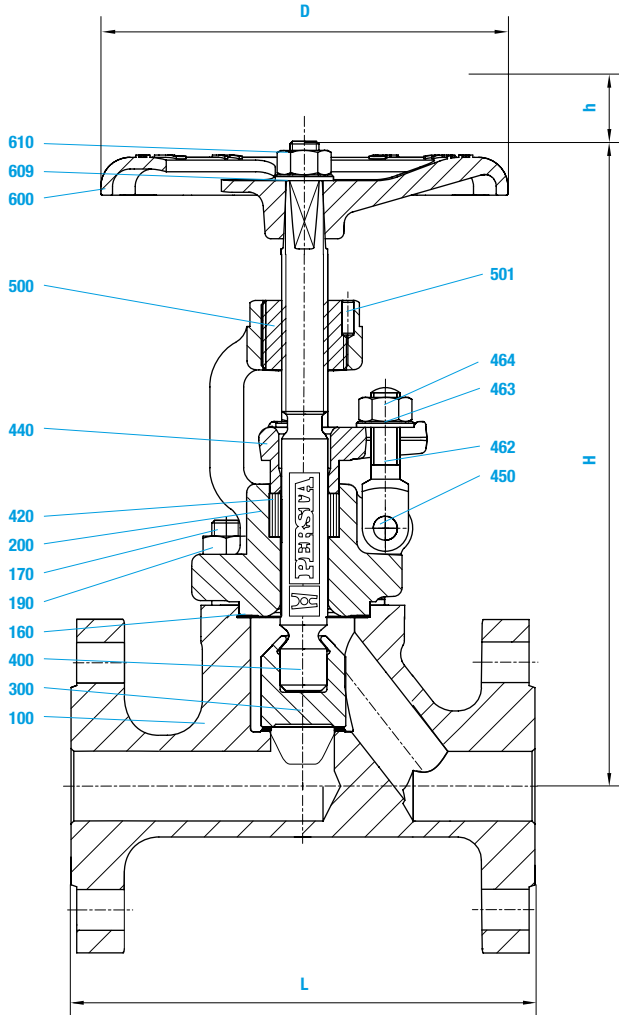

**Globe valve AJ/BJ**

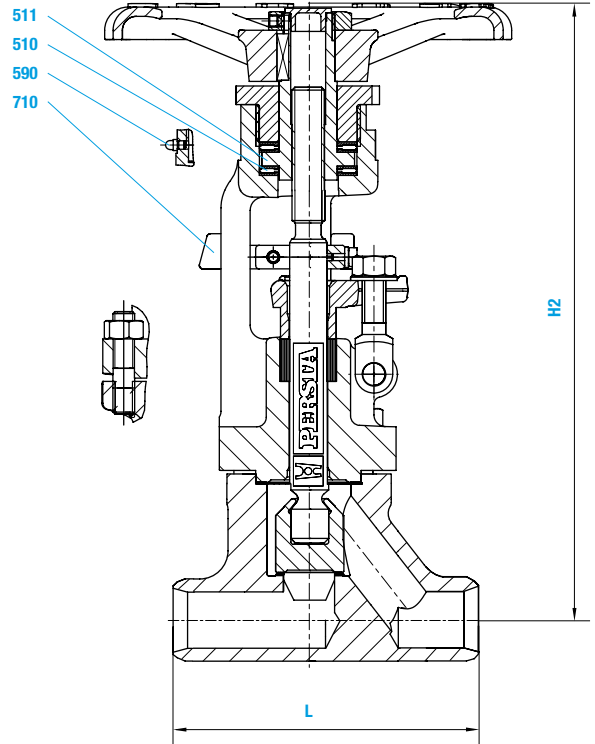

**Lift check valve**

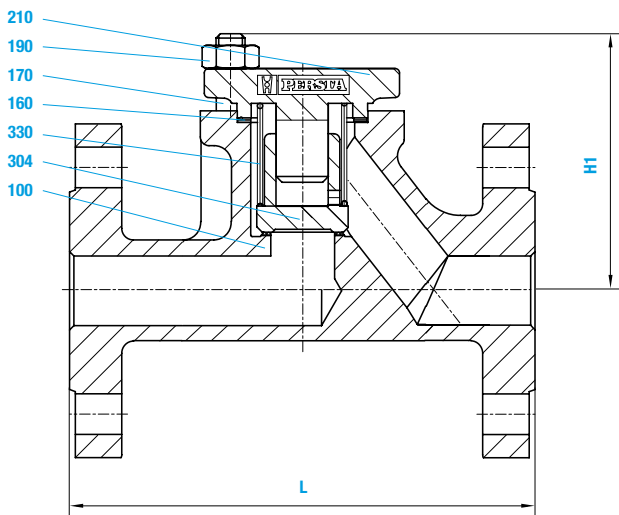

**BW-Version**

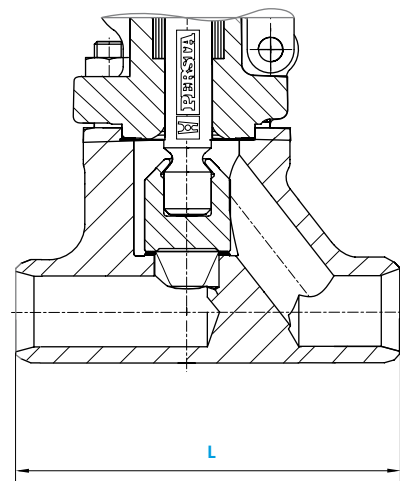

- **Globe valves** ▪ **Globe valve** ▪ **200 AE/BE/AJ/BJ** ▪ **PN 10-160** ▪ **DN 10-50**
- **Globe valves** ▪ **Lift check valve** ▪ **240 MT** ▪ **PN 10-160** ▪ **DN 10-50**

Materials							
Pos.	Component	1.0460 (21)	1.0566 (25)	BW-Version 1.5415 (42)	1.7335 (44)	1.4571 (82)	1.4571 (87)
100	Body	1.0460 <sup>4(8)</sup>	1.0566 <sup>4)</sup>	1.5415 <sup>5)</sup>	1.7335 <sup>5)</sup>	1.4571 <sup>7)</sup>	1.4571 <sup>7)</sup>
160	▶ Gasket	Graphite	Graphite	Graphite	Graphite	Teflon	Graphite
170	Stud <sup>1)</sup>	1.1181	A4-70	1.7709	1.7709	A4-70	A4-70
170	Stud <sup>2)</sup>	1.7709	A4-70	1.4923	1.4923	A4-70	A4-70
190	Hexagonal nut <sup>1)</sup>	1.1181	A4-70	1.7218	1.7218	A4-70	A4-70
190	Hexagonal nut <sup>2)</sup>	1.7218	A4-70	1.7218	1.7218	A4-70	A4-70
200	Bonnet	1.0460	1.0566	1.7335	1.7335	1.4571	1.4571
210	Bonnet	1.0460	1.0566	1.7335	1.7335	1.4571	1.4571
300	▶ Disc	1.4021 <sup>3)</sup>	1.0566 <sup>4)</sup>	1.7335 <sup>5)</sup>	1.7335 <sup>5)</sup>	1.4571 <sup>6)</sup>	1.4571 <sup>6)</sup>
304	▶ Disc	1.4021 <sup>3)</sup>	1.4571 <sup>6)</sup>	1.4571 <sup>5)</sup>	1.4571 <sup>5)</sup>	1.4571 <sup>6)</sup>	1.4571 <sup>6)</sup>
330	▶ Spring	1.4310	1.4310	1.4310	1.4310	1.4571	1.4571
400	▶ Stem	1.4021	1.4571	1.4021	1.4021	1.4571	1.4571
420	▶ Packing	Graphite	Graphite	Graphite	Graphite	Teflon	Graphite
440	Gland flange	1.0460	1.4571	1.0460	1.0460	1.4571	1.4571
450	Rivet	1.1181	A4-50	1.1181	1.1181	A4-50	A4-50
462	Gland bolt	1.1181	1.4571	1.1181	1.1181	1.4571	1.4571
463	Washer	St	A4-50	St	St	A4-50	A4-50
464	Hexagonal nut	1.1181	A4-70	1.1181	1.1181	A4-70	A4-70
500	▶ Stem nut	1.0718	1.0718	1.0718	1.0718	1.0718	1.0718
501	▶ Cylindrical pin	St	St	St	St	St	St
510	▶ Yoke sleeve	1.0718	1.0718	1.0718	1.0718	1.0718	1.0718
511	▶ Needle bearing	WLS	WLS	WLS	WLS	WLS	WLS
590	Grease nipple	5.8	5.8	5.8	5.8	5.8	5.8
600	Handwheel	5.3106	5.3106	5.3106	5.3106	5.3106	5.3106
609	Washer	St	St	St	St	A4-50	A4-50
610	Hexagonal nut	1.1181	1.1181	1.1181	1.1181	A4-70	A4-70
710	Anti-rotation device	5.3106	5.3106	5.3106	5.3106	5.3106	5.3106

▶ Spare parts  
Special materials on request; alterations reserved.

1) PN 10-40  
2) PN 63-160  
3) Seat hard faced  
4) Seat hard faced with Cr17  
5) Seat hard faced with Stellite  
6) ≥ PN 63 seat hard faced with Stellite  
7) ≥ PN 63 seat hard faced with hastelloy  
8) DN 50 PN 10-160 Flange Version with 1.0619 hard faced with Cr17

Dimensions/mm									
PN	DN	FL L	BW L	H	H1	H2	Stroke h	D	1.0619 H
<b>10-40</b>	<b>10</b>	130	130	215	85	275	12	140	
	<b>15</b>	130	130	215	85	275	12	140	
	<b>20</b>	150	130	220	90	275	12	140	
	<b>25</b>	160	130	220	90	275	12	140	
	<b>32</b>	180	160	245	115	305	15	180	
	<b>40</b>	200	180	250	130	305	15	180	
<b>63-160</b>	<b>50</b>	230	210	260	120	345	18	180	
	<b>10</b>	210	150	220	100	275	12	180	
	<b>15</b>	210	150	220	100	275	12	180	
	<b>20</b>	230	150	220	100	275	12	180	
	<b>25</b>	230	160	220	100	275	12	180	
	<b>32</b>	260	180	285	140	335	15	225	
<b>63-100</b>	<b>40</b>	260	210	285	140	335	15	225	
	<b>50</b>	300	250	285	150	345	18	150	260
<b>160</b>	<b>50</b>	300	250	285	150	345	18	225	260

The valves are also available in angle pattern up DN 100.

Weights/kg					
PN	DN	200 AE/BE		240 MT	
		FL	BW	FL	BW
<b>10-40</b>	<b>10</b>	4,5	3,8	3,2	2,4
	<b>15</b>	5,0	4,2	3,2	2,4
	<b>20</b>	5,7	3,8	3,9	2,4
	<b>25</b>	6,3	4,0	4,7	2,3
	<b>32</b>	10,0	7,3	7,9	5,5
	<b>40</b>	11,2	7,3	9,1	5,5
<b>63-160</b>	<b>50</b>	15,5	11,0	12,1	7,9
	<b>10</b>	8,7	5,9	6,0	4,0
	<b>15</b>	8,6	6,2	6,8	4,0
	<b>20</b>	10,4	5,5	9,0	4,0
	<b>25</b>	10,9	5,8	9,2	4,0
	<b>32</b>	19,0	13,2	15,6	9,0
<b>63-100</b>	<b>40</b>	21,0	12,8	16,8	9,0
	<b>50</b>	24,1	15,0	19,5	11,0
<b>160</b>	<b>50</b>	25,0	15,0	22,0	11,0

Kvs-values (m3/h)														
Line	DN 10	DN 15	DN 20	PN 10-40				DN 10	DN 15	DN 20	PN 63-160			
				DN 25	DN 32	DN 40	DN 50				DN 25	DN 32	DN 40	DN 50
<b>200 AE (BW)</b>	3,0	4,5	6,2	8,6	16,0	21,0	30,0	3,0	4,5	6,2	8,6	16,0	21,0	30,0
<b>200 AE (FL)</b>	1,8	3,0	5,3	8,6	13,0	21,0	37,2	1,8	4,5	5,3	8,6	13,0	21,0	37,2
<b>200 BE (BW)</b>	2,8	4,2	5,9	7,6	14,5	19,5	26,9	2,8	4,2	5,9	7,6	14,5	19,5	26,9
<b>200 BE (FL)</b>	1,5	2,8	4,9	7,6	11,2	19,5	34,5	2,8	4,2	5,9	7,6	14,5	19,5	34,5
<b>240 MT (BW)</b>	2,7	4,1	5,7	7,9	14,6	19,2	34,0	2,7	4,1	5,7	7,9	14,6	19,2	34,0
<b>240 MT (FL)</b>	1,7	2,7	5,7	7,9	11,9	19,2	25,8	1,7	2,7	5,7	7,9	11,9	19,2	25,8

- **Globe valves** ▪ **Globe valve** ▪ **200 AE/BE/AJ/BJ** ▪ **PN 10-160** ▪ **DN 65-200**
- **Globe valves** ▪ **Lift check valve** ▪ **240 MT** ▪ **PN 10-160** ▪ **DN 65-200**



### Range of application

Admissible operating pressure [bar] at design temperature [°C] <sup>1)</sup>

Material	PN	Admissible operating pressure [bar] at design temperature [°C] <sup>1)</sup>																					
		-200	-50	-10	20	100	120	150	200	250	300	350	400	425	450	475	500	510	520	530	540	550	
<b>1.0619</b>	<b>10-16</b>			16	16	16	16	15	14	13	11	10	8										
	<b>25</b>			25	25	25	25	23	22	20	17	16	13										
	<b>40</b>			40	40	40	40	37	35	32	28	24	21										
	<b>63</b>			63	63	63	63	53	50	45	40	36	32										
	<b>100</b>			100	100	100	100	83	80	70	60	56	50										
	<b>160</b> <sup>3)</sup>			160	160	160	160	135	130	112	96	90	80										
<b>1.5419</b>	<b>10</b>			10	10	9	9	9	8	7	7	7	6	6	6	6	3	3	2	2			
	<b>25</b>			25	25	23	23	22	20	19	17	16	16	16	15	15	9	7	6	4			
	<b>40</b>			40	40	36	36	35	31	29	27	26	25	24	24	23	14	11	9	7			
	<b>63</b>			63	63	59	59	58	51	48	45	42	41	40	39	38	22	18	14	12			
	<b>100</b>			100	100	92	92	90	80	74	69	65	63	62	61	59	35	28	22	18			
	<b>160</b> <sup>3)</sup>			160	160	148	148	143	128	119	111	104	101	100	98	94	55	44	35	29			
<b>1.7221</b>	<b>10-16</b> <sup>2)</sup>			16	16	16	16	15,1	15	14	13	11											
	<b>25</b> <sup>2)</sup>			25	25	25	25	23,6	23	22	20	17											
	<b>40</b> <sup>2)</sup>			40	40	40	40	37,7	37	35	32	28											
	<b>63</b> <sup>2)</sup>			63	63	63	55	54	53	50	45	40											
	<b>100</b> <sup>2)</sup>			100	100	100	87	84	83	80	70	60											
	<b>160</b> <sup>2)</sup>			160	160	160	140	136	135	130	112	96											
<b>1.7357</b>	<b>10-16</b>			16	16	16	16	15	14	13	11	10	8										
	<b>25</b>			25	25	25	25	25	25	25	25	25	24	23	22	21	20	18	15	12	9		
	<b>40</b>			40	40	40	40	40	40	40	40	40	38	36	35	34	33	29	24	19	15		
	<b>63</b>			63	63	63	63	63	63	63	63	61	58	57	56	51	47	40	32	25			
	<b>100</b> <sup>4)</sup>			100	100	100	100	100	100	100	100	95	91	89	87	80	74	62	49	38			
<b>1.4308</b>	<b>10-16</b>	16	16	16	16	13	12,6	12	11	8	8												
	<b>25</b>	25	25	25	25	21	19,8	18	17	13	12												
	<b>40</b>	40	40	40	40	34	32,4	30	24	21	20												
<b>1.4581</b>	<b>10-16</b>			16	16	15	14,6	14	13	13	12	12	11	10	8	7,5	7	7	7	7	7	6,5	
	<b>25</b>			25	25	24	23,2	22	21	20	19	18	17	16	13	12,5	12	11	11	11	11	11	
	<b>40</b>			40	40	38	36,8	35	33	32	30	28	26	24	21	20	19	19	19	19	18	18	

1) Operating temperature = design temperature minus temperature surcharge acc. to DIN regulations.  
 2) At temperature > 50 °C only applicable for short-time service.  
 3) PN 160 is only valid for DN 65-100.  
 4) Only for globe valves DN 65-80; for lift check valves DN 65-125.

Permissible differential pressure (pressure inlet below the disc) acc. to EN 13709.

- **Globe valves** ▪ **Globe valve** ▪ **200 AE/BE/AJ/BJ** ▪ **PN 10-160** ▪ **DN 65-200**
- **Globe valves** ▪ **Lift check valve** ▪ **240 MT** ▪ **PN 10-160** ▪ **DN 65-200**

#### Standard features

- Straight bonnet
- Cast steel body and bonnet
- Shut-off disc, Fig. No. AE
- Shut-off disc with yoke sleeve standard features AJ
- Throttle disc with yoke sleeve standard features BJ
- Throttle disc, Fig. No. 200 BE
- Outside screw and yoke
- Position indicator if required
- Turning and rising stem (AE/BE)
- Non-turning, rising stem (AJ/BJ)

#### Pressure and temperature ratings

- Pressure rating BW-Ends up to 160 bar
- Pressure rating FL up to 160 bar
- Temperature rating up to 550 °C

#### Materials

- 1.0619
- 1.5419
- 1.7221
- 1.7357
- 1.4581
- 1.4308

Further materials on request.

#### Media

Depending on the material the valves are suitable for water, gas, oil and other non aggressive media

#### Fields of application

Chemical industries, power plant, ship building and other

#### Design Highlights

- Seats are welded on
- Body-bonnet connection male and female
- Body and bonnet in two pieces with bolted connection

#### Benefits

- Extremely resistant to wear
- Sealing blow out proof
- To ease maintenance work, e.g. regrinding

- **Globe valves** ▪ **Globe valve** ▪ **200 AE/BE/AJ/BJ** ▪ **PN 10-160** ▪ **DN 65-200**
- **Globe valves** ▪ **Lift check valve** ▪ **240 MT** ▪ **PN 10-160** ▪ **DN 65-200**

**Globe valve AE/BE**

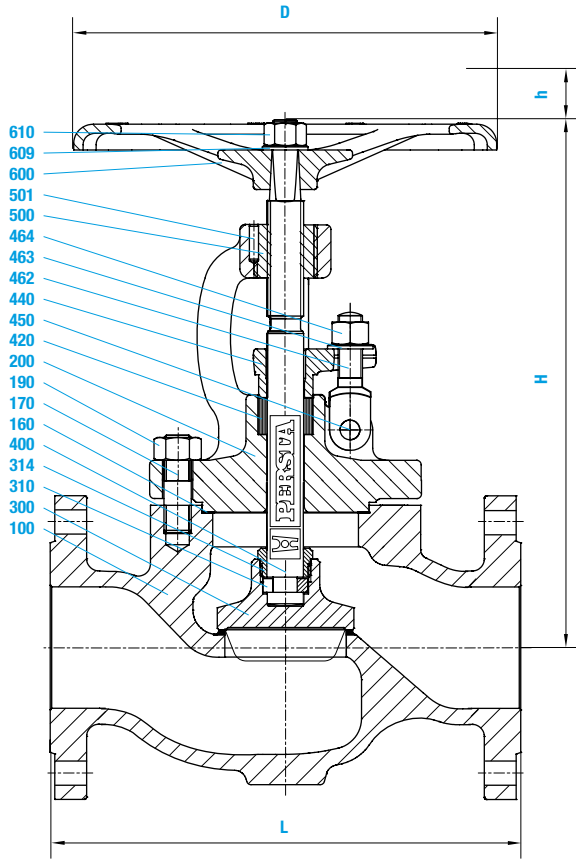

**Globe valve AJ/BJ**

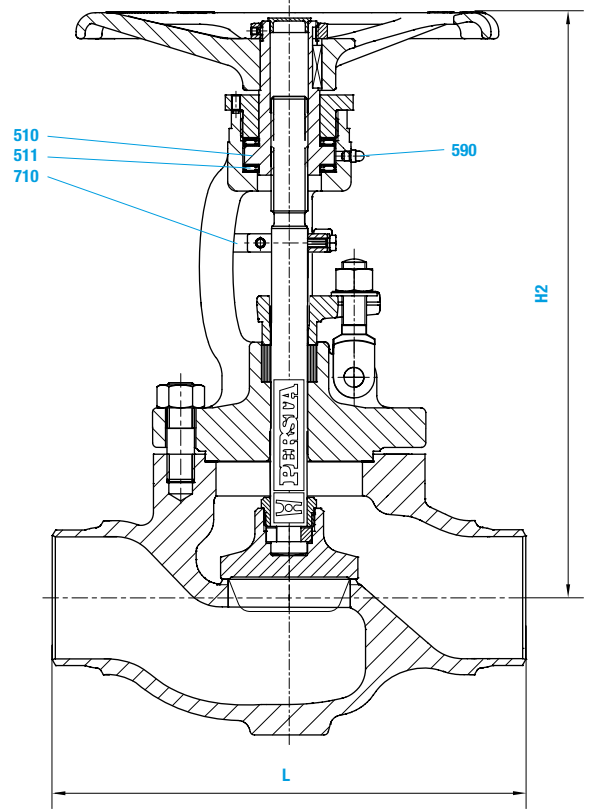

**Lift check valve**

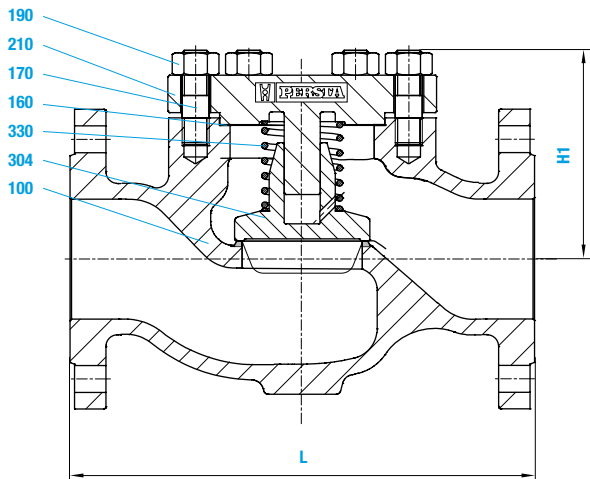

**BW-Version**

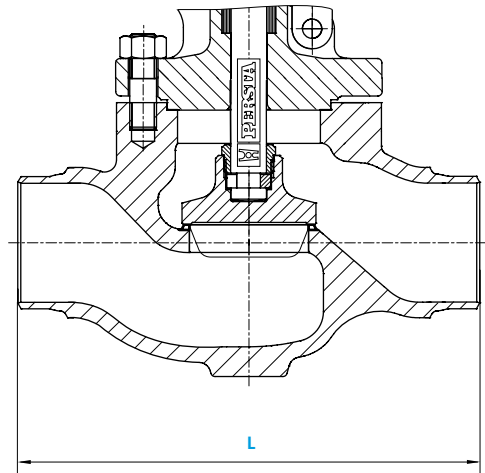

▪ **Globe valves** ▪ **Globe valve** ▪ **200 AE/BE/AJ/BJ** ▪ **PN 10-160** ▪ **DN 65-200**

▪ **Globe valves** ▪ **Lift check valve** ▪ **240 MT** ▪ **PN 10-160** ▪ **DN 65-200**

Materials							
Pos.	Component	1.0619 (11)	1.5419 (32)	1.7221 (31)	1.7357 (34)	1.4581 (72)	1.4308 (77)
100	Body	1.0619 <sup>4)</sup>	1.5419 <sup>5)</sup>	1.7221	1.7357 <sup>5)</sup>	1.4581 <sup>9)</sup>	1.4308 <sup>9)</sup>
160	▶ Gasket	Graphite	Graphite	Graphite	Graphite	Teflon	Graphite
170	Stud <sup>1)</sup>	1.1181	1.7709	A4-70	1.7709	A4-70	A4-70
170	Stud <sup>2)</sup>	1.7709	1.4923	A4-70	1.4923		
190	Hexagonal nut <sup>1)</sup>	1.1181	1.7218	A4-70	1.7218	A4-70	A4-70
190	Hexagonal nut <sup>2)</sup>	1.7218	1.7218	A4-70	1.7218		
200	Bonnet	1.0619	1.7357	1.7221	1.7357	1.4581	1.4308
210	Cover	1.0460	1.7335	1.0566	1.7335	1.4571	1.4571
300	▶ Disc	1.4021 <sup>3)</sup>	1.7335 <sup>5)</sup>	1.0566 <sup>4)</sup>	1.7335 <sup>5)</sup>	1.4571 <sup>8)</sup>	1.4571 <sup>8)</sup>
304	▶ Disc	1.0460 <sup>3)</sup>	1.7335 <sup>5)</sup>	1.0566 <sup>4)</sup>	1.7335 <sup>5)</sup>	1.4571 <sup>8)</sup>	1.4571 <sup>8)</sup>
310	▶ Filling piece	1.0035	1.0035	1.0035	1.0035	1.4571	1.4571
314	▶ Disc nut	1.0050	1.0050	1.0050	1.0050	1.4571	1.4571
330	▶ Spring	1.4310	1.4310	1.4310	1.4310	1.4571	1.4571
400	▶ Stem	1.4021	1.4021	1.4571	1.4021	1.4571	1.4571
420	▶ Packing	Graphite	Graphite	Graphite	Graphite	Teflon	Graphite
440	Gland flange	1.0460	1.0460	1.4571	1.0460	1.4571	1.4571
450	Rivet	1.1181	1.1181	A4-50	1.1181	A4-50	A4-50
462	Gland bolt	1.1181	1.1181	1.4571	1.1181	1.4571	1.4571
463	Washer	St	St	A4-50	St	A4-50	A4-50
464	Hexagonal nut	1.1181	1.1181	A4-70	1.1181	A4-70	A4-70
500	▶ Stem nut	1.0718	1.0718	1.0718	1.0718	1.0718	1.0718
501	▶ Cylindrical pin	St	St	St	St	St	St
510	▶ Yoke sleeve	1.0718	1.0718	1.0718	1.0718	1.0718	1.0718
511	▶ Bearing	WLS	WLS	WLS	WLS	WLS	WLS
590	Grease nipple	5.8	5.8	5.8	5.8	5.8	5.8
600	Handwheel	5.3106	5.3106	5.3106	5.3106	5.3106	5.3106
600	Handwheel	5.3106	5.3106	5.3106	5.3106	5.3106	5.3106
609	Washer	St	St	St	St	A4-50	A4-50
610	Hexagonal nut	1.1181	1.1181	1.1181	1.1181	A4-70	A4-70
710	Anti-rotation device	5.3106	5.3106	5.3106	5.3106	5.3106	5.3106

▶ Spare parts      Special materials on request; alterations reserved.

1) PN 10-40      2) PN 63-160      3) Seat hard faced ≥ DN 125, 1.0460 seat hard faced with Cr17      4) Seat hard faced with Cr17      5) Seat hard faced with stellite      6) ≥ PN 63 seat hard faced with hastelloy      7) ≥ PN 63 seat hard faced with hastelloy

Dimensions/mm								
PN	DN	FL L	BW L	Stroke H	h	H1	D	H2
<b>10-40</b>	<b>65</b>	290	290	310	22	105	225	330
	<b>80</b>	310	310	360	25	115	280	390
	<b>100</b>	350	350	400	30	140	280	400
	<b>125</b>	400	400	465	40	145	360	495
	<b>150</b>	480	480	530	50	170	360	530
<b>200</b>	600	600	575	65	240	450	575	
<b>63-160</b>	<b>65</b>	340	340	360	22	120	280	360
	<b>80</b>	380	380	400	25	145	280	400
	<b>100</b>	430	430	410	30	165	360	410
<b>63</b>	<b>125</b>	500	500	535	40	210	360	535
	<b>150</b>	550	550	555	50	235	450	555
<b>100</b>	<b>125</b>	500	500	535	40	210	360	535
	<b>150</b>	550	550	555	50	235	450	555

Weights/kg									
DN	200 AE / BE								
	PN 10-16 FL	PN 25-40 FL	PN 10-40 BW	PN 63 FL	PN 63 BW	PN 100 FL	PN 100 BW	PN 160 FL	PN 160 BW
<b>65</b>	27,5	27,5	16,0	34,0	24,0	34,0	24,0	39,0	24,0
	37,0	37,0	28,0	47,0	36,0	47,0	36,0	51,0	36,0
	52,0	53,0	41,0	72,0	56,0	72,0	56,0	80,0	56,0
	69,0	69,0	55,0	117,0	93,0	120,0	93,0		
	103,0	110,5	97,0	160,0	125,0	166,0	125,0		
<b>200</b>	171,0	175,0	156,0						
DN	240 MT								
	PN 10-16 FL	PN 25-40 FL	PN 10-40 BW	PN 63 FL	PN 63 BW	PN 100 FL	PN 100 BW	PN 160 FL	PN 160 BW
<b>65</b>	18,5	18,5	11,5	29,0	13,0	29,0	13,0	33,0	13,0
	29,6	29,6	20,4	42,0	23,0	42,0	23,0	46,0	23,0
	35,4	35,4	29,0	63,0	38,0	63,0	38,0	71,0	38,0
	58,0	58,0	40,0	101,0	78,0	106,0	78,0		
	80,0	80,0	65,0	145,0	110,0	150,0	110,0		
<b>200</b>	145,0	160,0	148,0						

Kvs-values (m3/h) BW- and FL-version						
Line	DN 65	DN 80	DN 100	DN 125	DN 150	DN 200
	PN 10-160	PN 10-160	PN 10-160	PN 10-160	PN 10-160	PN 10-40
<b>200 AE / AJ</b>	71,0	122,0	162,0	260,0	370,0	660,0
<b>200 BE / BJ</b>	61,5	78,0	104,0	171,0	250,0	422,0
<b>240 MT</b>	72,1	105,9	171,6	263,0	374,0	688,0

The valves are also available in angle pattern up to DN 100 nominal sizes > DN 200 on request.

Permissible differential pressure (pressure inlet below the disc) acc. to EN 13709. **DN bar** 65 80 100 125 150 200 110 70 44 33 21 14