

Cast Carbon Steel Globe Valve

Bolted bonnet, Outside screw-and-yoke, Rising stem handwheel, Swivel disc.

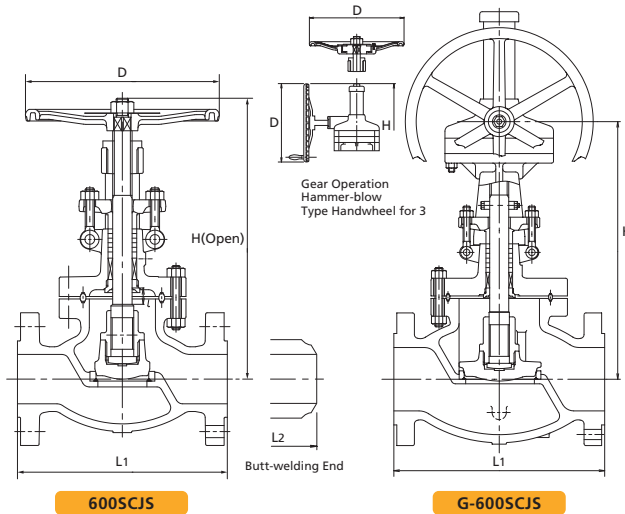

Fig	End Connections
(G-)600SCJS	RF-flanged ends.
(G-)W600SCJS	Butt-welding ends.

Standard materials of parts

Parts	Materials
Body	ASTM A216 Gr.WCB
Bonnet	ASTM A216 Gr.WCB
Stem	403SS
Disc	•403SS or A217 Gr.CA15 or A216 Gr.WCB+13Cr •403SS (Size 4 only) A105+13Cr (Size 6-10) A216 Gr.WCB+13Cr (Size 12 only)
Lock nut	403SS
Body seat ring	Carbon Steel+HF*
Gland	403SS
Gland packing	Flexible Graphite
Gland flange	Carbon Steel/Cast Steel
Handwheel	Ductile iron
Gasket	See Page 5
Bonnet bolt/nut	ASTM A193 Gr.B7/A194 Gr.2H
Gland bolt/nut	Carbon Steel or Alloy Steel
Bonnet bushing	403SS
Yoke bush	Ductile Ni-Resist

*Hard facing with Co-Cr-W Alloy.

Note: Refer to Table 2&4 for standard seat material and construction.

Dimensions

Nominal Size	2		2½		3		4		5		6		8		10		12	
		50		65		80		100		125		150		200		250		300
L1	in	11.5	in	13.0	in	14.0	in	17.0	in	20.0	in	22.0	in	26.0	in	31.0	in	33.0
	mm	292	mm	330	mm	356	mm	432	mm	508	mm	559	mm	660	mm	787	mm	838
L2	in	11.5	in	13.0	in	14.0	in	17.0	in	20.0	in	22.0	in	26.0	in	31.0	in	33.0
	mm	292	mm	330	mm	356	mm	432	mm	508	mm	559	mm	660	mm	787	mm	838
H*	in	16.0	in	18.7	in	20.0	in	35.3	in	36.6	in	39.1	in	44.1	in	55.9	in	62.0
	mm	406	mm	474	mm	508	mm	897	mm	930	mm	993	mm	1121	mm	1420	mm	1575
D	in	9.80	in	11.8	in	13.8	in	19.7	in	19.7	in	19.7	in	23.6	in	23.6	in	24.0
	mm	250	mm	300	mm	350	mm	500	mm	500	mm	500	mm	600	mm	610	mm	610

*Size 4 and larger : Gear operation type.
Refer to "Standard Product Range" on page 01.