

## Bolted bonnet, Outside screw-and-yoke, Rising stem handwheel, Swivel disc.

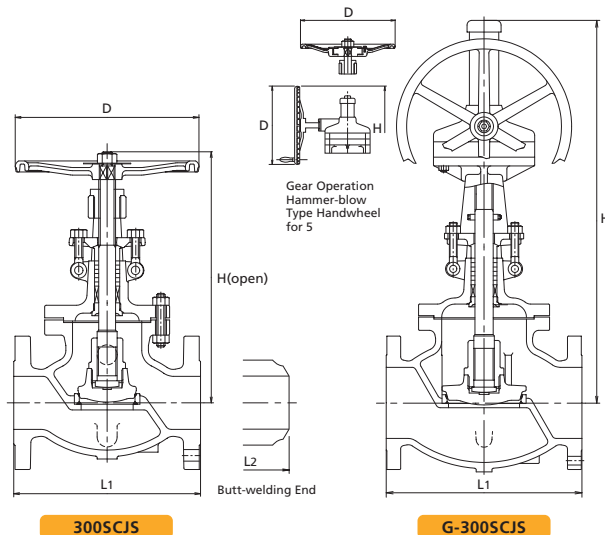

Fig	End Connections
<b>(G-)300SCJS</b>	RF-flanged ends.
<b>(G-)W300SCJS</b>	Butt-welding ends.

### Standard materials of parts

Parts	Materials
<b>Body</b>	ASTM A216 Gr.WCB
<b>Bonnet</b>	ASTM A216 Gr.WCB
<b>Stem</b>	403SS
<b>Disc</b>	403SS or A217 Gr.CA15 or A216 Gr.WCB+13Cr or A105+13Cr
<b>Lock nut</b>	403SS
<b>Body seat ring</b>	Carbon Steel+HF*
<b>Gland</b>	403SS
<b>Gland packing</b>	Flexible Graphite
<b>Gland flange</b>	Carbon Steel/Cast Steel
<b>Handwheel</b>	Ductile iron
<b>Gasket</b>	See Page 5
<b>Bonnet bolt/nut</b>	ASTM A193 Gr.B7/A194 Gr.2H
<b>Gland bolt/nut</b>	Carbon Steel
<b>Bonnet bushing</b>	403SS
<b>Yoke bush</b>	Ductile Ni-Resist

\*Hard facing with Co-Cr-W Alloy.

Note: Refer to Page 2&4 for standard seat material and construction.

### Dimensions

Nominal Size	Nominal Size												
	1½	2	2½	3	4	5	6	8	10	12	14	16	
L <sub>1</sub>	in	9.02	10.5	11.5	12.5	14.0	15.8	17.5	22.0	24.5	28.0	33.0	34.0
	mm	229	267	292	318	356	400	444	559	622	711	838	864
L <sub>2</sub>	in	—	10.5	11.5	12.5	14.0	15.8	17.5	22.0	24.5	28.0	33.0	34.0
	mm	—	267	292	318	356	400	444	559	622	711	838	864
H*	in	14.2	14.2	16.9	17.2	20.0	24.0	38.9	41.9	45.0	46.7	57.1	55.5
	mm	361	361	428	436	509	610	989	1064	1142	1187	1450	1410
D	in	7.90	7.90	9.80	9.80	13.8	15.7	17.7	19.7	23.6	23.6	23.6	23.6
	mm	200	200	250	250	350	400	500	500	600	600	600	600

\*Size 6 and larger : Gear operation type.  
Refer to "Standard Product Range" on page 01.