

# Cast Carbon Steel Globe Valve

Bolted bonnet, Outside screw-and-yoke, Rising stem handwheel, Swivel disc.

Class 1500

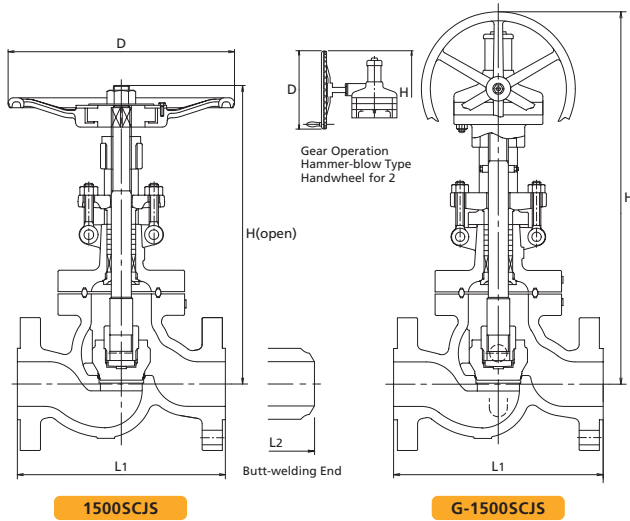

Fig	End Connections
(G-)1500SCJS	RF-flanged ends.
(G-)W1500SCJS	Butt-welding ends.

## Standard materials of parts

Parts	Materials
Body	ASTM A216 Gr.WCB+HF*
Bonnet	ASTM A216 Gr.WCB
Stem	403SS
Disc	403SS (Size 2-1/2-4) A105+13Cr' (Size 6-8)
Lock nut	403SS
Gland	403SS
Gland packing	Flexible Graphite
Gland flange	Carbon Steel
Handwheel	Ductile iron
Gasket	See Page 5
Bonnet bolt/nut	ASTM A193 Gr.B7/A194 Gr.2H
Gland bolt/nut	Carbon Steel
Bonnet bushing	403SS
Yoke bush	Ductile Ni-Resist

\*Hard facing with Co-Cr-W Alloy.  
Note: Refer to Page 2&4 for standard seat material and construction.

## Dimensions

Nominal Size		2	2 1/2	3	4	6	8
		50	65	80	100	150	200
L <sub>1</sub>	in	14.5	16.5	18.5	21.5	27.8	32.8
	mm	368	419	470	546	705	832
L <sub>2</sub>	in	14.5	16.5	18.5	21.5	27.8	32.8
	mm	368	419	470	546	705	832
H*	in	21.3	36.2	38.0	43.4	53.8	55.1
	mm	540	920	964	1102	1366	1400
D	in	13.8	19.7	19.7	23.6	23.6	24.0
	mm	350	500	500	600	600	610

\*Size 2 1/2 and larger : Gear operation type.  
Refer to "Standard Product Range" on page 01.