

FORGED STEEL VALVES

DOUGLAS CHERO SpA
dc FORGED VALVES



Ratings (ASTM A105)

300 p.s.i. @ 850°F
740 p.s.i. @ 100°F

Test pressure (ASTM A105)

Hydraulic: (minimum)
Body - 1125 p.s.i.
Seat - 825 p.s.i.
Air under water:
not applicable

Standards

Construction BS 5352
Flanged ASME B16.5, ASME B16.10
Test BS 6755 (Pt.1)

Connections (xx)

RF Raised face (std.)	LF Large female
RJ Ring joint	LG Large groove
SF Small female	LM Large male
SG Small groove	LT Large tongue
SM Small male	
ST Small tongue	

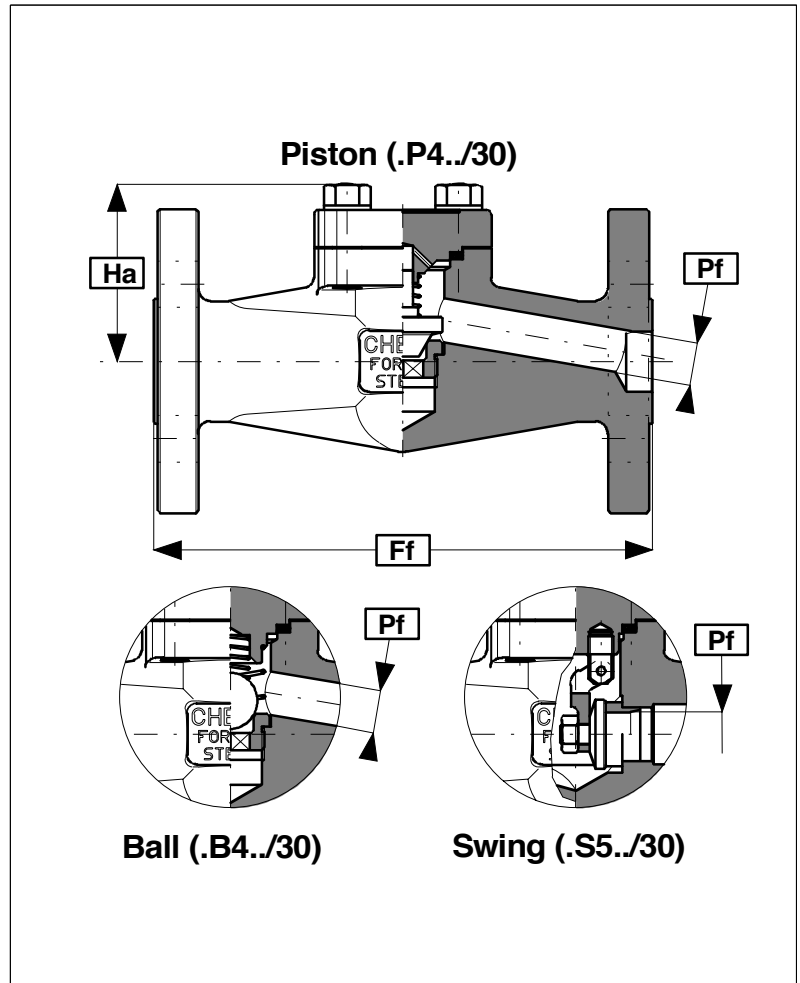

REDUCED BORE											
		1/2"		3/4"		1"		1.1/2"		2"	
Ff (mm/in)		152,4	6,00	177,8	7,00	203,2 ⁽⁶⁾	8,00	228,6 ⁽⁶⁾	9,00	266,7	10,50
Ha (mm/in)		50	1,97	56	2,20	74	2,91	100	3,94	109	4,29
Pf⁽⁷⁾(mm/in)		9	0,35	12,5	0,49	17,5	0,69	28 ⁽⁴⁾	1,10	32 ⁽⁵⁾	1,26
Wt. (kg/lb)		2,5	5,5	4,2	9,2	5,7	12,5	11,2	24,6	14,4	31,7
Catal. no.		Rtt52/30xx		Rtt53/30xx		Rtt54/30xx		Rtt56/30xx		Rtt57/30xx	

FULL BORE											
		1/2"		3/4"		1"		1.1/2"		2"	
Ff (mm/in)		152,4	6,00	177,8	7,00	203,2 ⁽⁶⁾	8,00	228,6 ⁽⁶⁾	9,00	266,7	10,50
Ha (mm/in)		50	1,97	56	2,20	92	3,62	110	4,33	140	5,51
Pf⁽⁷⁾(mm/in)		12,5	0,49	17,5	0,69	22,5	0,89	35	1,38	45	1,77
Wt. (kg/lb)		2,5	5,5	4,2	9,2	5,7	12,5	11,2	24,6	14,4	31,7
Catal. no.		Ftt52/30xx		Ftt53/30xx		Ftt54/30xx		Ftt56/30xx		Ftt57/30xx	

1) Standard and alternative valve materials on page 67, type B
2) Complete Pressure-Temperature ratings on page 68, 69, 70, 71,72
3) Flanges & face-to face dimensions on page 74,75

4) Pf = 29,5 with integral stellited seat
5) Pf = 35 with integral stellited seat
6) Swing 1"=215,9 (8,50) - Swing 1.1/2" = 241,3 (9,50)

7) Dimensions for piston & ball type; for swing see page 4
8) Code it is replaced by kind of check valve (drawing above)