

# FORGED STEEL VALVES

DOUGLAS CHERO SpA  
**dc** FORGED VALVES

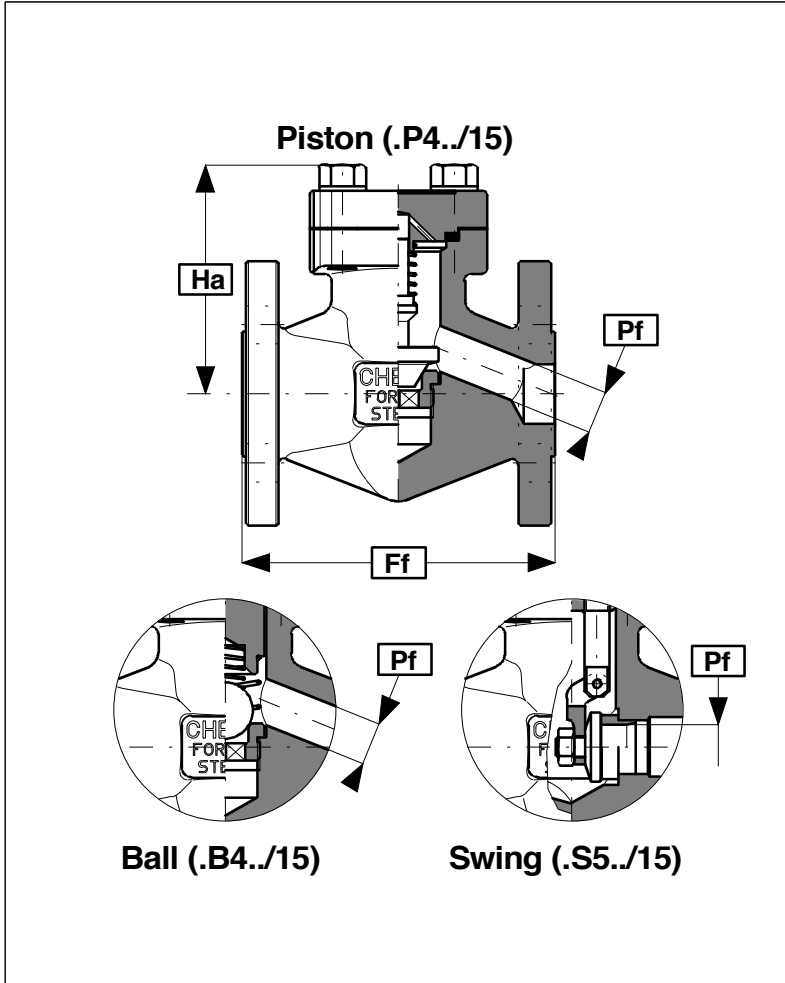

**Ratings (ASTM A105)**

 150 p.s.i. @ 550°F  
 285 p.s.i. @ 100°F

**Test pressure (ASTM A105)**
**Hydraulic:(minimum)**  
 Body - 450 p.s.i.  
 Seat - 325 p.s.i.  
**Air under water:**  
 not applicable

**Standards**
**Construction**      BS 5352  
**Flanged**            ASME B16.5, ASME B16.10  
**Test**                  BS 6755 (Pt.1)

**Connections (xx)**
**RF**      Raised face (std.)  
**FF**      Flat finish

REDUCED BORE												
			1/2"		3/4"		1"		1.1/2"		2"	
<b>Ff (mm/in)</b>			107,9	4,25	117,5	4,63	127,0	5,00	165,1	6,50	203,2	8,00
<b>Ha (mm/in)</b>			84	3,31	87	3,43	92	3,62	97	3,82	124	4,88
<b>Pf<sup>(6)</sup>(mm/in)</b>			9	0,35	12,5	0,49	17,5	0,69	28 <sup>(4)</sup>	1,10	32 <sup>(5)</sup>	1,26
<b>Wt. (kg/lb)</b>			2,6	5,7	3,8	8,4	5,1	11,2	8,4	18,5	14,2	31,2
<b>Catal. no.</b>			Rtt52/15xx		Rtt53/15xx		Rtt54/15xx		Rtt56/15xx		Rtt57/15xx	

FULL BORE												
			1/2"		3/4"		1"		1.1/2"		2"	
<b>Ff (mm/in)</b>			107,9	4,25	117,5	4,63	127,0	5,00	165,1	6,50	203,2	6,50
<b>Ha (mm/in)</b>			84	3,31	87	3,43	92	3,62	110	4,33	124	4,88
<b>Pf<sup>(6)</sup>(mm/in)</b>			12,5	0,49	17,5	0,69	22,5	0,89	32	1,38	38	1,50
<b>Wt. (kg/lb)</b>			2,6	5,7	3,8	8,4	5,1	11,2	8,4	18,5	14,7	31,2
<b>Catal. no.</b>			Ftt12/15xx		Ftt13/15xx		Ftt14/15xx		Ftt16/15xx		Ftt17/15xx	

 1) Standard and alternative valve materials on page 67, type B  
 2) Complete Pressure-Temperature ratings on page 68, 69, 70,71,72  
 3) Flanges & face-to-face dimensions on page 74,75

 4) Pf = 29,5 with integral stellited seat  
 5) Pf = 35 with integral stellited seat  
 6) Dimensions for piston & ball type; for swing see page 4

7) Code tt is replaced by kind of check valve (drawing above)