

FORGED STEEL VALVES

DOUGLAS CHERO SpA
dc FORGED VALVES



Ratings (ASTM A105)

150 p.s.i. @ 550°F
285 p.s.i. @ 100°F

Test pressure (ASTM A105)

Hydraulic:(minimum)
Body - 450 p.s.i.
Seat - 325 p.s.i.
Air under water:
Seat - 85 p.s.i.

Standards

Construction BS 5352
Flanged ASME B16.5, ASME B16.10
Test BS 6755 (Pt.1)

Connections (xx)

RF Raised face (std.)
FF Flat finish

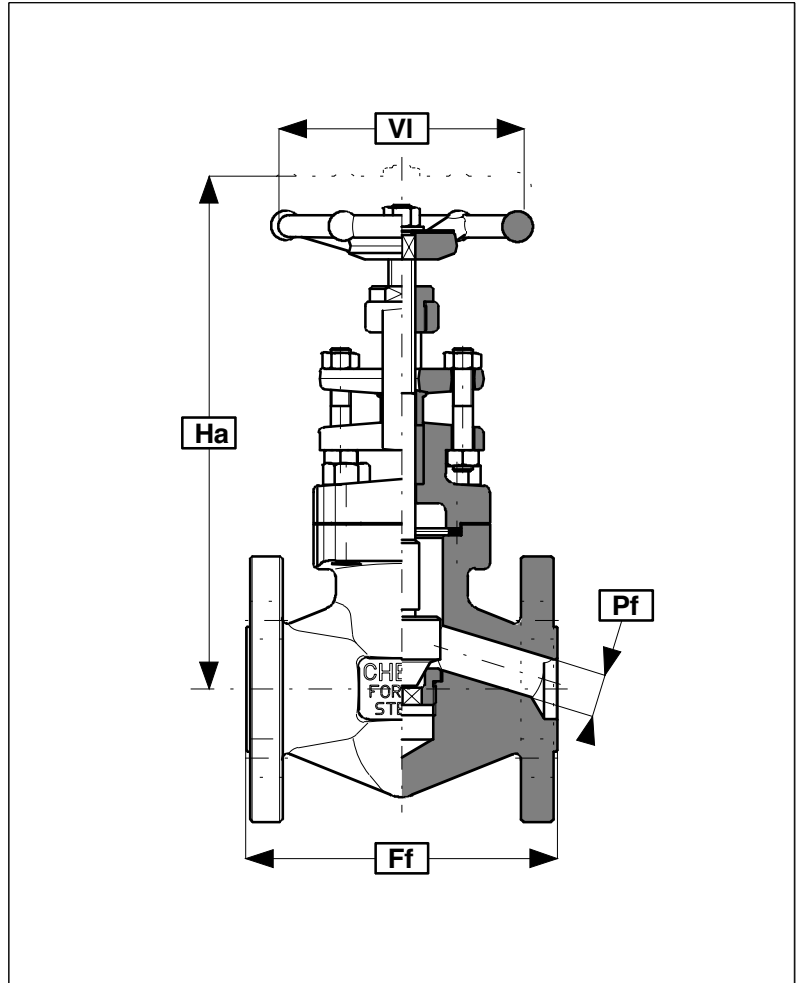
REDUCED BORE

		1/2"		3/4"		1"		1.1/2"		2"	
Ff (mm/in)		107,9	4,25	117,5	4,63	127,0	5,00	165,1	6,50	203,2	8,00
Ha (mm/in)		186	7,32	189	7,44	203	7,99	283	11,14	314	12,36
VI (mm/in)		90	3,54	90	3,54	100	3,94	140	5,51	140	5,51
Pf (mm/in)		9	0,35	12,5	0,49	17,5	0,69	28 ⁽⁴⁾	1,10	32 ⁽⁵⁾	1,26
Wt. (kg/lb)		3,1	6,8	4	8,8	5,7	12,5	10,6	23,3	15,4	33,9
Catal. no.		R352/15xx		R353/15xx		R354/15xx		R356/15xx		R357/15xx	

FULL BORE

		1/2"		3/4"		1"		1.1/2"		2"	
Ff (mm/in)		107,9	4,25	117,5	4,63	127,0	5,00	165,1	6,50	203,2	8,00
Ha (mm/in)		188	7,40	192	7,56	207	8,15	283	11,14	314	12,36
VI (mm/in)		90	3,54	100	3,94	120	4,72	140	5,51	200	7,87
Pf (mm/in)		12,5	0,49	17,5	0,69	22,5	0,89	32	1,26	38	1,57
Wt. (kg/lb)		3	6,6	3,9	8,6	5,6	12,3	10,6	23,3	15,8	34,8
Catal. no.		F312/15xx		F313/15xx		F314/15xx		F316/15xx		F317/15xx	

1) Standard and alternative valve materials on page 67, type A
2) Complete Pressure-Temperature ratings on page 68, 69, 70, 71,72
3) Flanges & face-to-face dimensions on page 74,75

4) Pf = 29,5 with integral stellited seat
5) Pf = 35 with integral stellited seat